

Service Manual

Air Conditioner

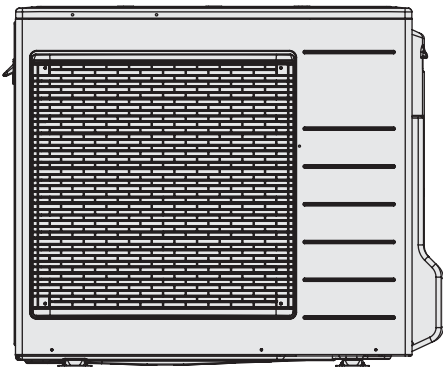
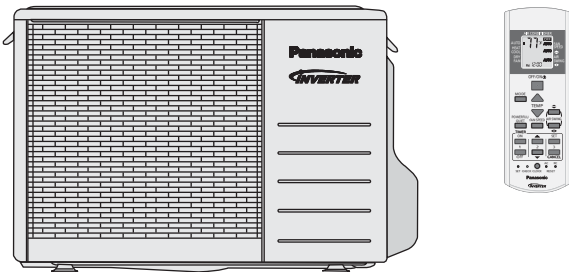

Indoor Unit
CS-RE9SKUA
CS-RE12SKUA
CS-RE18SKUA
CS-RE24SKUA

Outdoor Unit
CU-RE9SKUA
CU-RE12SKUA
CU-RE18SKUA
CU-RE24SKUA

Destination
USA
Canada

WARNING

This service information is designed for experienced repair technicians only and is not designed for use by the general public. It does not contain warnings or cautions to advise non-technical individuals of potential dangers in attempting to service a product. Products powered by electricity should be serviced or repaired only by experienced professional technicians. Any attempt to service or repair the products dealt with in this service information by anyone else could result in serious injury or death.

PRECAUTION OF LOW TEMPERATURE



In order to avoid frostbite, be assured of no refrigerant leakage during the installation or repairing of refrigerant circuit.

TABLE OF CONTENTS

1. Safety Precautions	3
2. Specification	5
3. Features	11
4. Location of Controls and Components	12
4.1 Indoor Unit	12
4.2 Outdoor Unit	12
4.3 Remote Control	12
5. Dimensions	13
5.1 Indoor Unit	13
5.2 Outdoor Unit	15
6. Refrigeration Cycle Diagram	16
6.1 CU-RE9SKUA CU-RE12SKUA	16
6.2 CU-RE18SKUA CU-RE24SKUA	17
7. Block Diagram	18
7.1 CS-RE9SKUA CU-RE9SKUA CS-RE12SKUA CU-RE12SKUA	18
7.2 CS-RE18SKUA CU-RE18SKUA CS-RE24SKUA CU-RE24SKUA	19
8. Wiring Connection Diagram	20
8.1 Indoor Unit	20
8.2 Outdoor Unit	22
9. Electronic Circuit Diagram	24
9.1 Indoor Unit	24
9.2 Outdoor Unit	26
10. Printed Circuit Board	28
10.1 Indoor Unit	28
10.2 Outdoor Unit	29
11. Installation Instruction (RE9SKUA and RE12SKUA)	31
11.1 Select the Best Location.....	31
11.2 Indoor Unit	32
11.3 Outdoor Unit	37
12. Installation Instruction (RE18SKUA and RE24SKUA)	40
12.1 Select the Best Location.....	40
12.2 Indoor Unit	41
12.3 Outdoor Unit	46
13. Operation Control	50
13.1 Basic Function	50
13.2 Indoor Fan Speed Control	51
13.3 Indoor Fan Motor Operation	52
13.4 Outdoor Fan Motor Operation	52
13.5 Airflow Direction.....	53
13.6 Quiet Operation (Cooling Mode/Cooling Area of Dry Mode).....	54
13.7 Quiet Operation (Heating)	55
13.8 Powerful Mode Operation.....	55
13.9 Timer Control.....	55
13.10 Auto Restart Control	56
13.11 Indication Panel.....	56
14. Protection Control (RE9SK and RE12SK)	57
14.1 Protection Control For All Operations.....	57
14.2 Protection Control For Cooling & Soft Dry Operation	59
15. Protection Control (RE18SK and RE24SK)	62
15.1 Protection Control For All Operations.....	62
15.2 Protection Control For Cooling & Soft Dry Operation	63
16. Servicing Mode	66
16.1 Auto Off/On Button	66
16.2 Cooling Only Operation	67
16.3 Remote Control Button	68
17. Troubleshooting Guide	69
17.1 Refrigeration Cycle System	69
17.2 Breakdown Self Diagnosis Function.....	71
17.3 Error Code Table	72
17.4 Self-diagnosis Method.....	74
18. Disassembly and Assembly Instructions ...	104
18.1 CS-RE9SKUA CS-RE12SKUA	104
18.2 CS-RE18SKUA CS-RE24SKUA	108
18.3 Outdoor Electronic Controller Removal Procedure	112
19. Technical Data	114
19.1 Cool Mode Performance Data	114
19.2 Heat Mode Performance Data.....	116
20. Service Data	117
20.1 CS-RE9SKUA CU-RE9SKUA	117
20.2 CS-RE12SKUA CU-RE12SKUA	117
20.3 CS-RE18SKUA CU-RE18SKUA	118
20.4 CS-RE24SKUA CU-RE24SKUA	118
20.5 CS-RE9SKUA CU-RE9SKUA	119
20.6 CS-RE12SKUA CU-RE12SKUA	119
20.7 CS-RE18SKUA CU-RE18SKUA	119
20.8 CS-RE24SKUA CU-RE24SKUA	119
20.9 Cool Mode Outdoor Air Temperature Characteristic.....	120
20.10 Heat Mode Outdoor Air Temperature Characteristic.....	124
20.11 Piping Length Correction Factor.....	128
21. Exploded View and Replacement Parts List	130
21.1 Indoor Unit	130
21.2 Outdoor Unit	134

1. Safety Precautions





- Read the following “SAFETY PRECAUTIONS” carefully before perform any servicing.
- Electrical work must be installed or serviced by a licensed electrician. Be sure to use the correct rating of the power plug and main circuit for the model installed.
- The caution items stated here must be followed because these important contents are related to safety. The meaning of each indication used is as below. Incorrect installation or servicing due to ignoring of the instruction will cause harm or damage, and the seriousness is classified by the following indications.

 WARNING	This indication shows the possibility of causing death or serious injury
 CAUTION	This indication shows the possibility of causing injury or damage to properties.

- The items to be followed are classified by the symbols:

	This symbol denotes item that is PROHIBITED from doing.
---	---







- Carry out test run to confirm that no abnormality occurs after the servicing. Then, explain to user the operation, care and maintenance as stated in instructions. Please remind the customer to keep the operating instructions for future reference.

 WARNING	
1. Do not modify the machine, part, material during repairing service.	
2. If wiring unit is supplied as repairing part, do not repair or connect the wire even only partial wire break. Exchange the whole wiring unit.	
3. Do not wrench the fasten terminal. Pull it out or insert it straightly.	
4. Engage authorized dealer or specialist for installation and servicing. If installation of servicing done by the user is defective, it will cause water leakage, electrical shock or fire.	
5. Install according to this installation instructions strictly. If installation is defective, it will cause water leakage, electric shock or fire.	
6. Use the attached accessories parts and specified parts for installation and servicing. Otherwise, it will cause the set to fall, water leakage, fire or electrical shock.	
7. Install at a strong and firm location which is able to withstand the set's weight. If the strength is not enough or installation is not properly done, the set will drop and cause injury.	
8. For electrical work, follow the local national wiring standard, regulation and the installation instruction. An independent circuit and single outlet must be used. If electrical circuit capacity is not enough or defect found in electrical work, it will cause electrical shock or fire.	
9. This equipment is strongly recommended to be installed with Earth Leakage Circuit Breaker (ELCB) or Residual Current Device (RCD). Otherwise, it may cause electrical shock and fire in case equipment breakdown or insulation breakdown.	
10. Do not use joint cable for indoor/outdoor connection cable. Use the specified indoor/outdoor connection cable, refer to installation instruction CONNECT THE CABLE TO THE INDOOR UNIT and connect tightly for indoor/outdoor connection. Clamp the cable so that no external force will be acted on the terminal. If connecting or fixing is not perfect, it will cause heat up or fire at the connection.	
11. Wire routing must be properly arranged so that control board cover is fixed properly. If control board cover is not fixed perfectly, it will cause heat-up or fire at the connection point of terminal, fire or electrical shock.	
12. When install or relocate air conditioner, do not let any substance other than the specified refrigerant, eg. air etc. mix into refrigeration cycle (piping). (Mixing of air etc. will cause abnormal high pressure in refrigeration cycle and result in explosion, injury etc.).	
13. Do not install outdoor unit near handrail of veranda. When installing air-conditioner unit at veranda of high rise building, child may climb up to outdoor unit and cross over the handrail and causing accident.	
14. This equipment must be properly earthed. Earth line must not be connected to gas pipe, water pipe, earth of lightning rod and telephone. Otherwise, it may cause electrical shock in case equipment breakdown or insulation breakdown.	
15. Keep away from small children, the thin film may cling to nose and mouth and prevent breathing.	
16. Do not use unspecified cord, modified cord, joint cord or extension cord for power supply cord. Do not share the single outlet with other electrical appliances. Poor contact, poor insulation or over current will cause electrical shock or fire.	
17. Tighten the flare nut with torque wrench according to specified method. If the flare nut is over-tightened, after a long period, the flare may break and cause refrigerant gas leakage.	
18. For R410A model, use piping, flare nut and tools which is specified for R410A refrigerant. Using of existing (R22) piping, flare nut and tools may cause abnormally high pressure in the refrigerant cycle (piping), and possibly result in explosion and injury. Thickness of copper pipes used with R410A must be more than 1/32" (0.8 mm). Never use copper pipes thinner than 1/32" (0.8 mm). It is desirable that the amount of residual oil is less than 0.0008 oz/ft (40 mg/10 m).	

 **WARNING**

19. During installation, install the refrigerant piping properly before run the compressor. (Operation of compressor without fixing refrigeration piping and valves at opened condition will cause suck-in of air, abnormal high pressure in refrigeration cycle and result in explosion, injury etc.).
20. During pump down operation, stop the compressor before remove the refrigeration piping. (Removal of refrigeration piping while compressor is operating and valves are opened condition will cause suck-in of air, abnormal high pressure in refrigeration cycle and result in explosion, injury etc.).
21. After completion of installation or service, confirm there is no leakage of refrigerant gas. It may generate toxic gas when the refrigerant contacts with fire.
22. Ventilate if there is refrigerant gas leakage during operation. It may cause toxic gas when the refrigerant contacts with fire.
23. Do not insert your fingers or other objects into the unit, high speed rotating fan may cause injury. 
24. Must not use other parts except original parts describe in catalog and manual.
25. Using of refrigerant other than the specified type may cause product damage, burst and injury etc.

 **CAUTION**

1. Do not install the unit at place where leakage of flammable gas may occur. In case gas leaks and accumulates at surrounding of the unit, it may cause fire. 
2. Carry out drainage piping as mentioned in installation instructions. If drainage is not perfect, water may enter the room and damage the furniture.
3. Tighten the flare nut with torque wrench according to specified method. If the flare nut is over-tightened, after a long period, the flare may break and cause refrigerant gas leakage.
4. Do not touch outdoor unit air inlet and aluminium fin. It may cause injury. 
5. Select an installation location which is easy for maintenance.
6. Pb free solder has a higher melting point than standard solder; typically the melting point is 50°F – 70°F (30°C – 40°C) higher. Please use a high temperature solder iron. In case of the soldering iron with temperature control, please set it to 700 ± 20°F (370 ± 10°C). Pb free solder will tend to splash when heated too high (about 1100°F / 600°C).
7. Power supply connection to the room air conditioner.
Power supply cord shall be UL listed or CSA approved 3 conductor with minimum AWG14 (For E9RK and E12RK) and AWG12 (For E18RK and E24RK) wires.
Power supply point should be in an easily accessible place for power disconnection in case of emergency.
In some countries, permanent connection of this air conditioner to the power supply is prohibited.
Fix power supply connection to a circuit breaker for permanent connection.
Use NRTL approved fuse or circuit breaker (rating refers to name plate) for permanent connection.
8. Do not release refrigerant during piping work for installation, servicing, reinstallation and during repairing a refrigerant parts. Take care of the liquid refrigerant, it may cause frostbite. 
9. Installation or servicing work: It may need two people to carry out the installation or servicing work.
10. Do not install this appliance in a laundry room or other location where water may drip from the ceiling, etc. 
11. Do not sit or step on the unit, you may fall down accidentally. 
12. Do not touch the sharp aluminium fins or edges of metal parts.
If you are required to handle sharp parts during installation or servicing, please wear hand glove. 
Sharp parts may cause injury.

2. Specification

Model		Indoor	CS-RE9SKUA						CS-RE12SKUA						
		Outdoor	CU-RE9SKUA						CU-RE12SKUA						
Performance Test Condition			ARI						ARI						
Power Supply		Phase, Hz	Single, 60						Single, 60						
		V	208			230			208			230			
			Min.	Mid.	Max.	Min.	Mid.	Max.	Min.	Mid.	Max.	Min.	Mid.	Max.	
Cooling	Capacity	kW	1.20	2.64	3.00	1.20	2.64	3.00	1.20	3.51	3.90	1.20	3.51	3.90	
		BTU/h	4100	9000	10200	4100	9000	10200	4100	12000	13300	4100	12000	13300	
	Running Current	A	-	4.2	-	-	3.8	-	-	5.5	-	-	5.0	-	
	Input Power	W	250	860	1.00k	250	860	1.00k	250	1.13k	1.30k	250	1.13k	1.30k	
	EER	W/W	4.80	3.06	3.00	4.80	3.06	3.00	4.80	3.10	3.00	4.80	3.10	3.00	
		Btu/hW	16.40	10.45	10.20	16.40	10.45	10.20	16.40	10.60	10.20	16.40	10.60	10.20	
	Power Factor	%	-	98	-	-	98	-	-	99	-	-	98	-	
	Indoor Noise (H / L / QLo)	dB-A	43 / 30 / 25			43 / 30 / 25			43 / 30 / 25			43 / 30 / 25			
		Power Level dB	59 / - / -			59 / - / -			59 / - / -			59 / - / -			
	Outdoor Noise (H / L / QLo)	dB-A	49 / - / -			49 / - / -			50 / - / -			50 / - / -			
Power Level dB		64 / - / -			64 / - / -			65 / - / -			65 / - / -				
Heating	Capacity	kW	1.20	3.21	4.14	1.20	3.21	4.14	1.20	3.51	4.77	1.20	3.51	4.77	
		BTU/h	4100	10900	14100	4100	10900	14100	4100	12000	16300	4100	12000	16300	
	Running Current	A	-	4.6	-	-	4.2	-	-	4.5	-	-	4.0	-	
	Input Power	W	200	950	1.50k	200	950	1.50k	200	910	1.71k	200	910	1.71k	
	COP	W/W	6.00	3.38	2.76	6.00	3.38	2.76	6.00	3.86	2.79	6.00	3.86	2.79	
		Btu/hW	20.50	11.45	9.40	20.50	11.45	9.40	20.50	13.15	9.50	20.50	13.15	9.50	
	Power Factor	%	-	99	-	-	98	-	-	97	-	-	99	-	
	Indoor Noise (H / L / QLo)	dB-A	43 / 35 / 32			43 / 35 / 32			44 / 36 / 32			44 / 36 / 32			
		Power Level dB	59 / - / -			59 / - / -			60 / - / -			60 / - / -			
	Outdoor Noise (H / L / QLo)	dB-A	49 / - / -			49 / - / -			52 / - / -			52 / - / -			
Power Level dB		64 / - / -			64 / - / -			67 / - / -			67 / - / -				
Max Current (A) / Max Input Power (W)			5.3 / 1.20k						7.0 / 1.61k						
Starting Current (A)			4.6						5.5						
Min Circuit Ampacity			15.0						15.0						
Max. Current Protection			15.0						15.0						
SEER / HSPF			16.00 / 8.50						16.00 / 8.50						
Compressor	Type	Hermetic Motor / Rotary						Hermetic Motor / Rotary							
	Motor Type	Brushless (6 poles)						Brushless (6 poles)							
	Output Power	W	700						700						
Indoor Fan	Type		Cross-flow fan						Cross-flow fan						
	Material		ASG20K1						ASG20K1						
	Motor Type		DC (8 poles)						DC (8 poles)						
	Input Power		W	47.0 - 47.0						47.0 - 47.0					
	Output Power		W	40						40					
	Speed	QLo	rpm	Cooling : 610 Heating : 730						Cooling : 620 Heating : 940					
		Lo	rpm	Cooling : 710 Heating : 830						Cooling : 780 Heating : 1040					
		Me	rpm	Cooling : 910 Heating : 1040						Cooling : 1000 Heating : 1210					
		Hi	rpm	Cooling : 1120 Heating : 1250						Cooling : 1230 Heating : 1380					
		SHi	rpm	Cooling : 1250 Heating : 1300						Cooling : 1350 Heating : 1430					

Model		Indoor	CS-RE9SKUA	CS-RE12SKUA
		Outdoor	CU-RE9SKUA	CU-RE12SKUA
Outdoor Fan	Type		Propeller	Propeller
	Material		PP	PP
	Motor Type		DC (8 poles)	DC (8 poles)
	Input Power	W	-	-
	Output Power	W	40	40
	Speed	Hi	rpm	C: 770 H: 750
Moisture Removal		L/h (Pt/h)	0.5 (1.3)	1.1 (2.3)
Indoor Airflow	QLo	m ³ /min (ft ³ /min)	Cooling : 5.87 (207) Heating : 6.95 (245)	Cooling : 5.75 (203) Heating : 9.30 (328)
	Lo	m ³ /min (ft ³ /min)	Cooling : 7.07 (250) Heating : 8.10 (286)	Cooling : 7.60 (268) Heating : 10.43 (368)
	Me	m ³ /min (ft ³ /min)	Cooling : 9.47 (334) Heating : 10.50 (371)	Cooling : 10.14 (358) Heating : 12.36 (436)
	Hi	m ³ /min (ft ³ /min)	Cooling : 12.0 (425) Heating : 12.9 (455)	Cooling : 12.8 (450) Heating : 14.3 (505)
	SHi	m ³ /min (ft ³ /min)	Cooling : 13.56 (479) Heating : 13.47 (476)	Cooling : 14.18 (501) Heating : 14.87 (525)
Outdoor Airflow	Hi	m ³ /min (ft ³ /min)	Cooling : 29.8 (1050) Heating : 29.8 (1050)	Cooling : 31.0 (1095) Heating : 31.0 (1095)
Refrigeration Cycle	Control Device		Expansion Valve	Expansion Valve
	Refrigerant Oil	cm ³	FV50S (320)	FV50S (320)
	Refrigerant Type	g (oz)	R410A, 900 (31.8)	R410A, 900 (31.8)
Dimension	Height(I/D / O/D)	mm (inch)	290 (11-7/16) / 542 (21-11/32)	290 (11-7/16) / 542 (21-11/32)
	Width (I/D / O/D)	mm (inch)	870 (34-9/32) / 780 (30-23/32)	870 (34-9/32) / 780 (30-23/32)
	Depth (I/D / O/D)	mm (inch)	214 (8-7/16) / 289 (11-13/32)	214 (8-7/16) / 289 (11-13/32)
Weight	Net (I/D / O/D)	kg (lb)	9 (20) 34 (75)	9 (20) 34 (75)
Piping	Pipe Diameter (Liquid / Gas)	mm (inch)	6.35 (1/4) / 9.52 (3/8)	6.35 (1/4) / 12.70 (1/2)
	Standard length	m (ft)	7.5 (24.6)	7.5 (24.6)
	Length range (min – max)	m (ft)	3 (9.8) ~ 15 (49.2)	3 (9.8) ~ 15 (49.2)
	I/D & O/D Height different	m (ft)	15 (49.2)	15 (49.2)
	Additional Gas Amount	g/m (oz/ft)	20 (0.2)	20 (0.2)
	Length for Additional Gas	m (ft)	7.5 (24.6)	7.5 (24.6)
Drain Hose	Inner Diameter	mm (inch)	16.7 (5/8)	16.7 (5/8)
	Length	mm (inch)	650 (25-5/8)	650 (25-5/8)
Indoor Heat Exchanger	Fin Material		Aluminium (Pre Coat)	Aluminium (Pre Coat)
	Fin Type		Slit Fin	Slit Fin
	Row × Stage × FPI		2 × 15 × 21	2 × 15 × 21
	Size (W × H × L)	inch	1 × 12-13/32 × 24	1 × 12-13/32 × 24
Outdoor Heat Exchanger	Fin Material		Aluminium (Blue coated)	Aluminium (Blue coated)
	Fin Type		Corrugate Fin	Corrugate Fin
	Row × Stage × FPI		2 × 24 × 17	2 × 24 × 17
	Size (W × H × L)	inch	1-13/32 × 19-13/16 × 28-1/16 26-15/16	1-13/32 × 19-13/16 × 28-1/16 26-15/16
Air Filter	Material		Polypropelene	Polypropelene
	Type		One-touch	One-touch
Power Supply			Outdoor	Outdoor
Power Supply Cord		A	-	-
Thermostat			-	-
Protection Device			-	-

Model	Indoor	CS-RE9SKUA		CS-RE12SKUA	
	Outdoor	CU-RE9SKUA		CU-RE12SKUA	
		DRY BULB	WET BULB	DRY BULB	WET BULB
Indoor Operation Range (Cooling) (°F / °C)	Maximum	89.6 / 32	73.4 / 23	89.6 / 32	73.4 / 23
	Minimum	60.8 / 16	51.8 / 11	60.8 / 16	51.8 / 11
Outdoor Operation Range (Cooling) (°F / °C)	Maximum	114.8 / 46	78.8 / 26	114.8 / 46	78.8 / 26
	Minimum	0 / -17.8	- / -	0 / -17.8	- / -
Indoor Operation Range (Heating) (°F / °C)	Maximum	86.0 / 30	- / -	86.0 / 30	- / -
	Minimum	60.8 / 16	- / -	60.8 / 16	- / -
Outdoor Operation Range (Heating) (°F / °C)	Maximum	75.2 / 24	64.4 / 18	75.2 / 24	64.4 / 18
	Minimum	-4 / -20	-2.2 / -19	-4 / -20	-2.2 / -19

1. Cooling capacities are based on indoor temperature of 27°C DRY BULB (80.6°F DRY BULB), 19.0°C WET BULB (66°F WET BULB) and outdoor air temperature of 35°C DRY BULB (95°F DRY BULB), 24°C WET BULB (75.2°F WET BULB)
2. Heating capacities are based on indoor temperature of 20°C Dry Bulb (68°F Dry Bulb) and outdoor air temperature of 7°C Dry Bulb (44.6°F Dry Bulb), 6°C Wet Bulb (42.8°F Wet Bulb)
3. Specifications are subjected to change without prior notice for further improvement.

Model		Indoor	CS-RE18SKUA						CS-RE24SKUA						
		Outdoor	CU-RE18SKUA						CU-RE24SKUA						
Performance Test Condition			ARI						ARI						
Power Supply		Phase, Hz	Single, 60						Single, 60						
		V	208			230			208			230			
		Min.	Mid.	Max.	Min.	Mid.	Max.	Min.	Mid.	Max.	Min.	Mid.	Max.		
Cooling	Capacity	kW	1.70	5.04	5.27	1.70	5.04	5.27	1.70	6.45	6.74	1.70	6.45	6.74	
		BTU/h	5800	17200	18000	5800	17200	18000	5800	22000	23000	5800	22000	23000	
	Running Current	A	-	7.00	-	-	6.30	-	-	11.70	-	-	10.50	-	
	Input Power	W	430	1.40k	1.55k	430	1.40k	1.55k	430	2.39k	2.55k	430	2.39k	2.55k	
	EER	W/W	3.95	3.60	3.40	3.95	3.60	3.40	3.95	2.70	2.64	3.95	2.70	2.64	
		Btu/hW	13.45	12.25	11.60	13.45	12.25	11.60	13.45	9.20	9.00	13.45	9.20	9.00	
	Power Factor	%	-	96	-	-	97	-	-	98	-	-	99	-	
	Indoor Noise (H / L / QLo)	dB-A	48 / 39 / 36			48 / 39 / 36			51 / 40 / 37			51 / 40 / 37			
		Power Level dB	64 / - / -			64 / - / -			67 / - / -			67 / - / -			
	Outdoor Noise (H / L / QLo)	dB-A	53 / - / -			53 / - / -			54 / - / -			54 / - / -			
Power Level dB		68 / - / -			68 / - / -			69 / - / -			69 / - / -				
Heating	Capacity	kW	1.70	5.28	6.12	1.70	5.28	6.12	1.70	8.45	7.44	1.70	8.45	7.44	
		BTU/h	5800	18000	20800	5800	18000	20800	5800	22000	25400	5800	22000	25400	
	Running Current	A	-	6.90	-	-	6.20	-	-	8.8	-	-	7.9	-	
	Input Power	W	380	1.38k	1.75k	380	1.38k	1.75k	380	1.78k	2.45k	380	1.78k	2.45k	
	COP	W/W	4.47	3.82	3.50	4.47	3.82	3.50	4.47	3.62	3.04	4.47	3.62	3.04	
		Btu/hW	15.25	13.00	11.85	15.25	13.00	11.85	15.25	12.35	10.35	15.25	12.35	10.35	
	Power Factor	%	-	96	-	-	97	-	-	97	-	-	98	-	
	Indoor Noise (H / L / QLo)	dB-A	48 / 39 / 36			48 / 39 / 36			51 / 40 / 37			51 / 40 / 37			
		Power Level dB	64 / - / -			64 / - / -			67 / - / -			67 / - / -			
	Outdoor Noise (H / L / QLo)	dB-A	54 / - / -			54 / - / -			55 / - / -			55 / - / -			
Power Level dB		69 / - / -			69 / - / -			70 / - / -			70 / - / -				
Max Current (A) / Max Input Power (W)		12.1 / 2.74k						12.5 / 2.87k							
Starting Current (A)		7.0						11.7							
Min Circuit Ampacity		15.0						20.0							
Max. Overcurrent Protection		20.0						25.0							
SEER / HSPF		16.00 / 8.50						16.00 / 8.50							
Compressor	Type	Hermetic Motor / Rotary						Hermetic Motor / Rotary							
	Motor Type	Brushless (4 poles)						Brushless (4 poles)							
	Output Power	W	900						900						
Indoor Fan	Type	Cross-flow fan						Cross-flow fan							
	Material	ASG30K1						ASG30K1							
	Motor Type	DC (8 poles)						DC (8 poles)							
	Input Power	W	94.8 - 94.8						94.8 - 94.8						
	Output Power	W	40						40						
	Speed	QLo	rpm	Cooling : 970 Heating : 1030						Cooling : 1000 Heating : 1110					
		Lo	rpm	Cooling : 1060 Heating : 1120						Cooling : 1090 Heating : 1220					
		Me	rpm	Cooling : 1220 Heating : 1260						Cooling : 1240 Heating : 1360					
		Hi	rpm	Cooling : 1380 Heating : 1410						Cooling : 1400 Heating : 1500					
		SHi	rpm	Cooling : 1480 Heating : 1500						Cooling : 1500 Heating : 1600					

Model		Indoor	CS-RE18SKUA	CS-RE24SKUA
		Outdoor	CU-RE18SKUA	CU-RE24SKUA
Outdoor Fan	Type		Propeller	Propeller
	Material		PP	PP
	Motor Type		DC Motor (8 poles)	DC Motor (8 poles)
	Input Power	W	-	-
	Output Power	W	40	40
	Speed	Hi	rpm	Cooling : 720 Heating : 700
Moisture Removal		L/h (Pt/h)	1.3 (2.7)	3.2 (6.8)
Indoor Airflow	QLo	m ³ /min (ft ³ /min)	Cooling : 12.73 (450) Heating : 13.82 (488)	Cooling : 12.98 (458) Heating : 14.49 (512)
	Lo	m ³ /min (ft ³ /min)	Cooling : 14.11 (498) Heating : 15.21 (537)	Cooling : 14.33 (506) Heating : 16.13 (570)
	Me	m ³ /min (ft ³ /min)	Cooling : 16.55 (584) Heating : 17.38 (614)	Cooling : 16.59 (586) Heating : 18.22 (643)
	Hi	m ³ /min (ft ³ /min)	Cooling : 19.00 (670) Heating : 19.70 (695)	Cooling : 19.00 (670) Heating : 20.30 (715)
	SHi	m ³ /min (ft ³ /min)	Cooling : 20.53 (725) Heating : 21.09 (745)	Cooling : 20.50 (724) Heating : 21.79 (769)
Outdoor Airflow	Hi	m ³ /min (ft ³ /min)	Cooling : 42.1 (1485) Heating : 41.5 (1465)	Cooling : 43.2 (1525) Heating : 42.6 (1505)
Refrigeration Cycle	Control Device		Expansion Valve	Expansion Valve
	Refrigerant Oil	cm ³	F50S (450)	F50S (450)
	Refrigerant Type	g (oz)	R410A, 1.24k (43.8)	R410A, 1.32k (46.6)
Dimension	Height(I/D / O/D)	mm (inch)	290 (11-7/16) / 695 (27-3/8)	290 (11-7/16) / 695 (27-3/8)
	Width (I/D / O/D)	mm (inch)	1070 (42-5/32) / 875 (34-15/32)	1070 (42-5/32) / 875 (34-15/32)
	Depth (I/D / O/D)	mm (inch)	240 (9-15/32) / 320 (12-5/8)	240 (9-15/32) / 320 (12-5/8)
Weight	Net (I/D / O/D)	kg (lb)	12 (26) 48 (106)	12 (26) 49 (108)
Piping	Pipe Diameter (Liquid / Gas)	mm (inch)	6.35 (1/4) / 12.70 (1/2)	6.35 (1/4) / 15.88 (5/8)
	Standard length	m (ft)	7.5 (24.6)	7.5 (24.6)
	Length range (min – max)	m (ft)	3 (9.8) ~ 20 (65.6)	3 (9.8) ~ 20 (65.6)
	I/D & O/D Height different	m (ft)	15 (49.2)	15 (49.2)
	Additional Gas Amount	g/m (oz/ft)	20 (0.2)	20 (0.2)
	Length for Additional Gas	m (ft)	7.5 (24.6)	7.5 (24.6)
Drain Hose	Inner Diameter	mm (inch)	16.7 (5/8)	16.7 (5/8)
	Length	mm (inch)	650 (25-5/8)	650 (25-5/8)
Indoor Heat Exchanger	Fin Material		Aluminium (Pre Coat)	Aluminium (Pre Coat)
	Fin Type		Slit Fin	Slit Fin
	Row × Stage × FPI		2 × 15 × 21	2 × 15 × 21
	Size (W × H × L)	inch	1 × 12-13/32 × 31-7/8	1 × 12-13/32 × 31-7/8
Outdoor Heat Exchanger	Fin Material		Aluminium (Blue coated)	Aluminium (Blue coated)
	Fin Type		Corrugate Fin	Corrugate Fin
	Row × Stage × FPI		2 × 31 × 19	2 × 31 × 19
	Size (W × H × L)	inch	1-13/32 × 25-5/8 × 33-5/8 32-15/32	1-13/32 × 25-5/8 × 33-5/8 32-15/32
Air Filter	Material		Polypropelene	Polypropelene
	Type		One-touch	One-touch
Power Supply			Outdoor	Outdoor
Power Supply Cord		A	-	-
Thermostat			-	-
Protection Device			-	-

Model	Indoor	CS-RE18SKUA		CS-RE24SKUA	
	Outdoor	CU-RE18SKUA		CU-RE24SKUA	
		DRY BULB	WET BULB	DRY BULB	WET BULB
Indoor Operation Range (Cooling) (°F / °C)	Maximum	89.6 / 32	73.4 / 23	89.6 / 32	73.4 / 23
	Minimum	60.8 / 16	51.8 / 11	60.8 / 16	51.8 / 11
Outdoor Operation Range (Cooling) (°F / °C)	Maximum	114.8 / 46	78.8 / 26	114.8 / 46	78.8 / 26
	Minimum	0 / -17.8	- / -	0 / -17.8	- / -
Indoor Operation Range (Heating) (°F / °C)	Maximum	86.0 / 30	- / -	86.0 / 30	- / -
	Minimum	60.8 / 16	- / -	60.8 / 16	- / -
Outdoor Operation Range (Heating) (°F / °C)	Maximum	75.0 / 24	64.4 / 18	75.0 / 24	64.4 / 18
	Minimum	-4 / -20	-2.2 / -19	-4 / -20	-2.2 / -19

1. Cooling capacities are based on indoor temperature of 80°F DRY BULB, 67°F WET BULB and outdoor air temperature of 95°F DRY BULB, 75°F WET BULB.
2. Heating capacities are based on indoor temperature of 70°F DRY BULB, 60°F WET BULB and outdoor air temperature of 47°F DRY BULB, 43°F WET BULB.
3. Specifications are subjected to change without prior notice for further improvement.

3. Features

- **Inverter Technology**
 - Wider output power range
 - Energy saving
 - Quick Cooling
 - More precise temperature control
- **Environment Protection**
 - Non-ozone depletion substances refrigerant (R410A)
- **Long Installation Piping**
 - CS/CU-RE9/12SK, long piping up to 65 feet (20 meters)
 - CS/CU-RE18/24SK, long piping up to 100 feet (30 meters)
- **Easy to use remote control**
- **Quality Improvement**
 - Random auto restart after power failure for safety restart operation
 - Gas leakage protection
 - Prevent compressor reverse cycle
 - Inner protector to protect Compressor
 - Noise prevention during soft dry operation
- **Operation Improvement**
 - Quiet mode to reduce the indoor unit operating sound
 - Powerful mode to reach the desired room temperature quickly
- **Serviceability Improvement**
 - Breakdown Self Diagnosis function

4. Location of Controls and Components

4.1 Indoor Unit

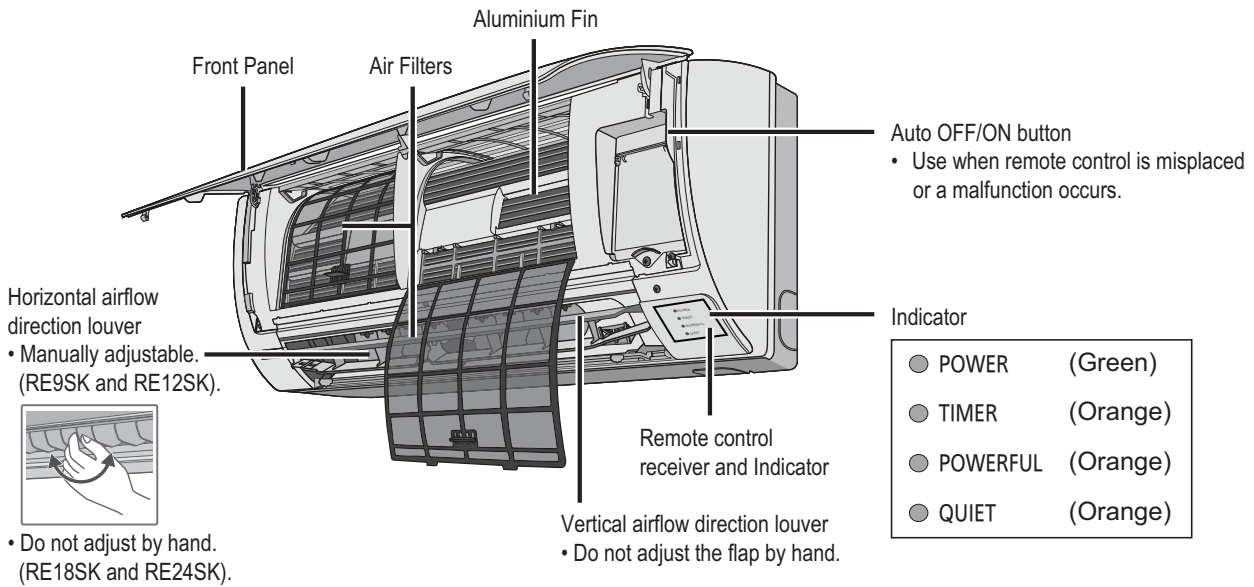

4.2 Outdoor Unit

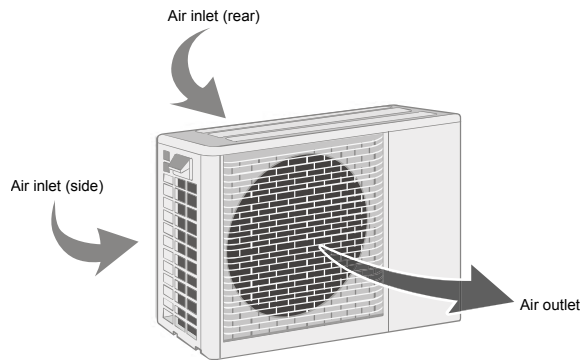

4.3 Remote Control

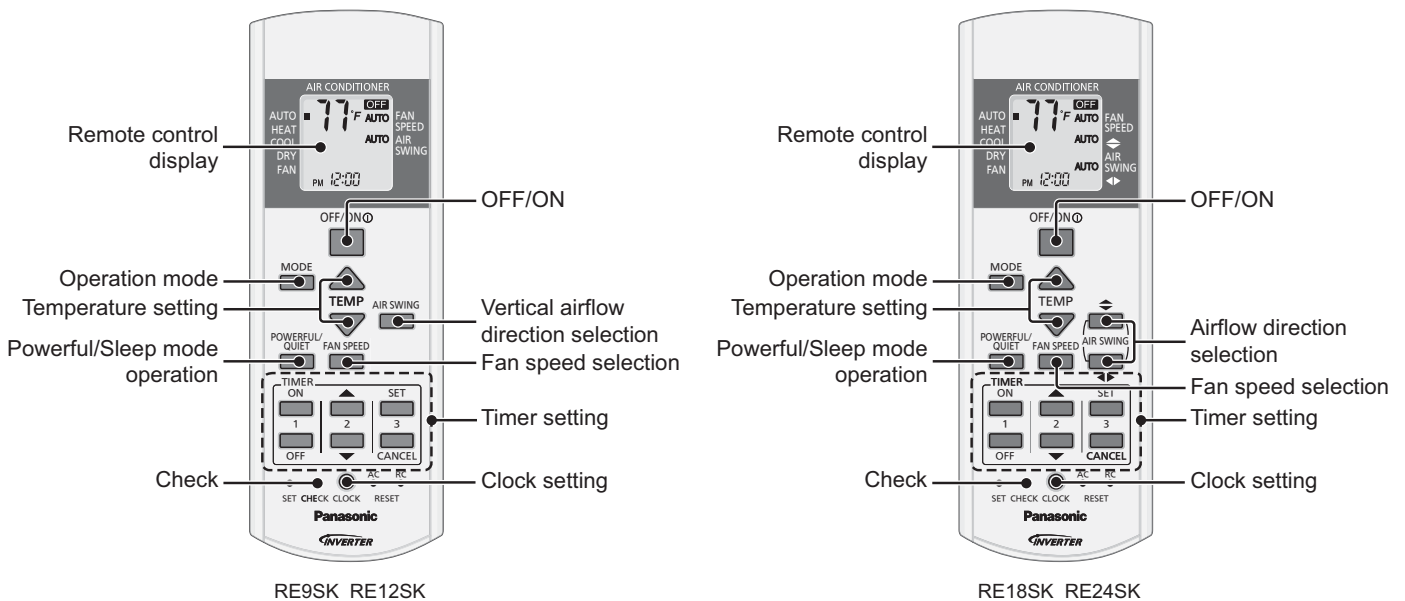

5. Dimensions

5.1 Indoor Unit

5.1.1 CS-RE9SKUA CS-RE12SKUA

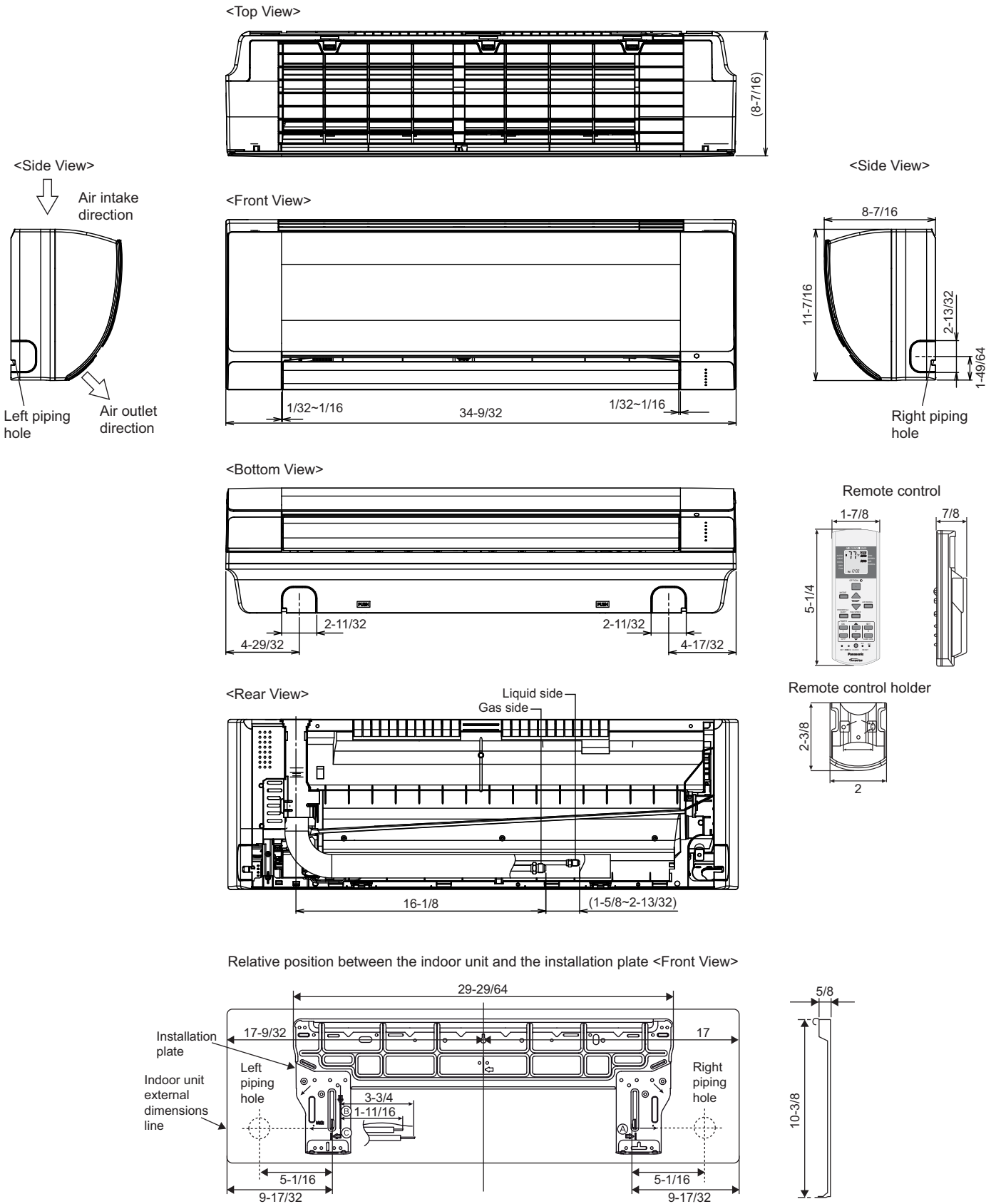

Unit: inch

5.1.2 CS-RE18SKUA CS-RE24SKUA

<Top View>

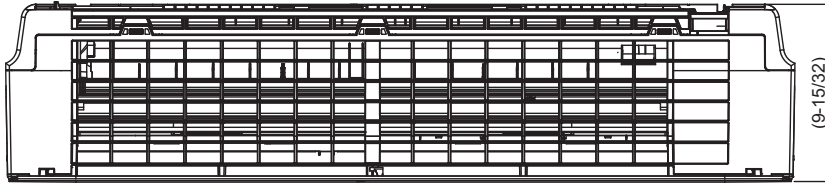

<Side View>

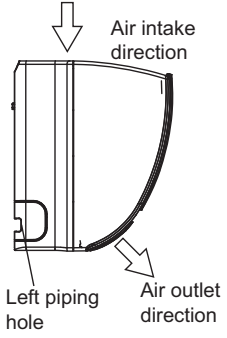

<Front View>

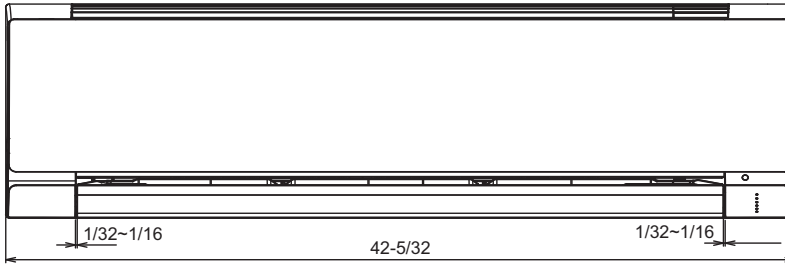

<Side View>

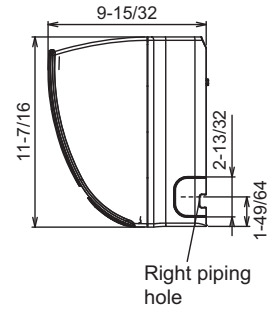

<Bottom View>

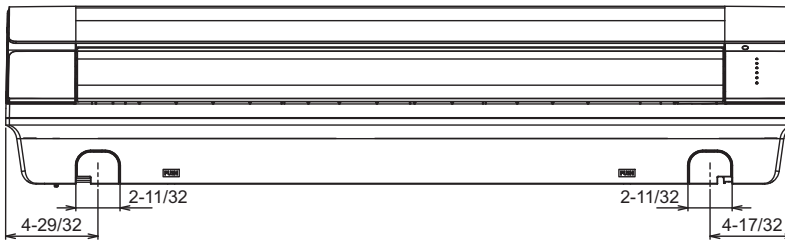

Remote control

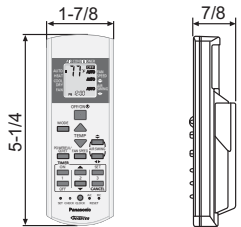

<Rear View>

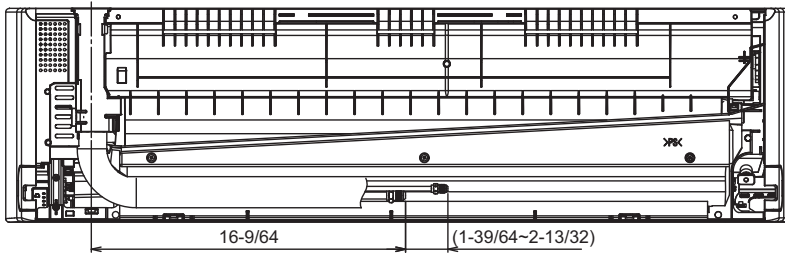

Remote control holder

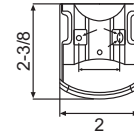

Relative position between the indoor unit and the installation plate <Front View>

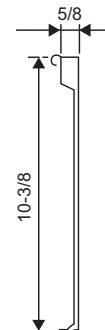
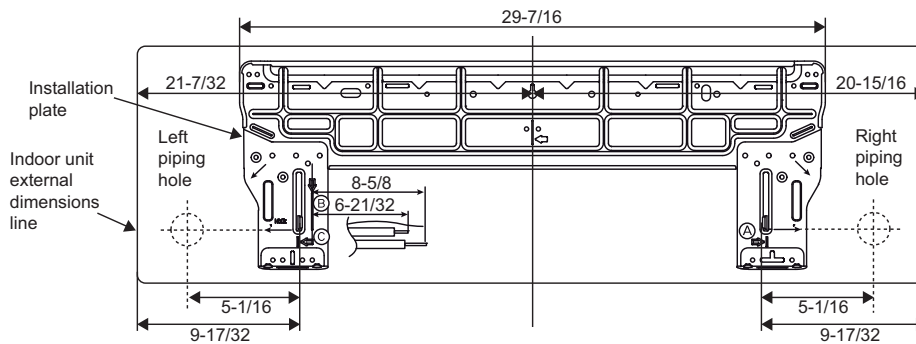

Unit: inch

5.2 Outdoor Unit

5.2.1 CU-RE9SKUA CU-RE12SKUA

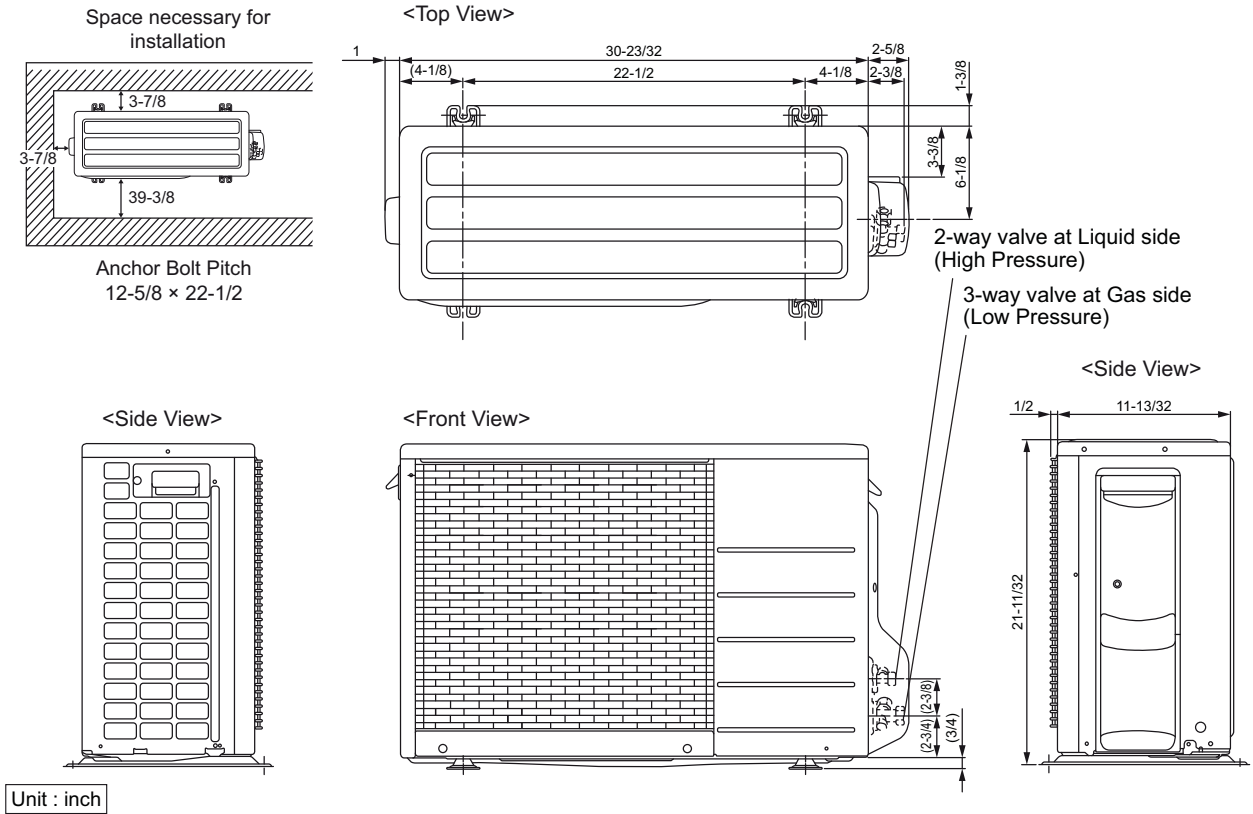

5.2.2 CU-RE18SKUA CU-RE24SKUA

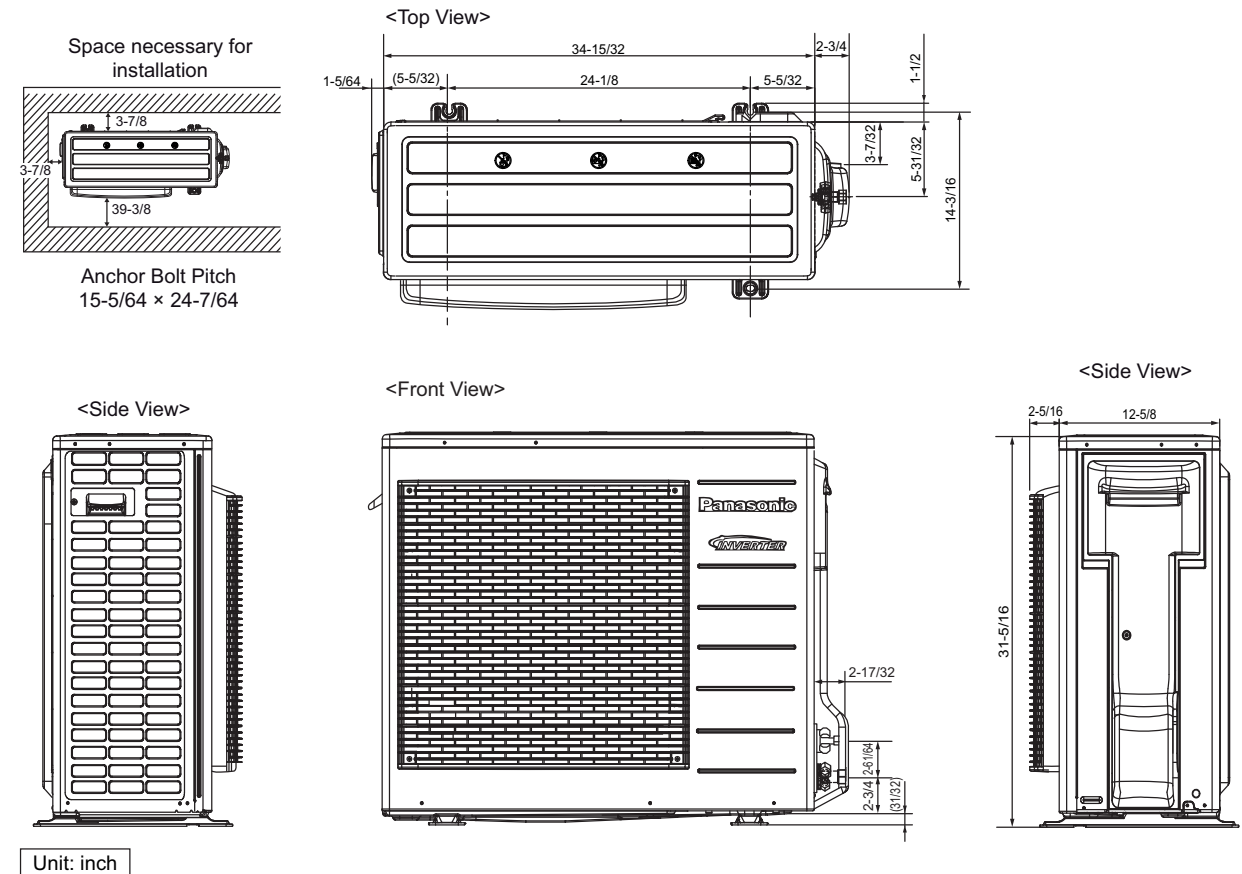

6. Refrigeration Cycle Diagram

6.1 CU-RE9SKUA CU-RE12SKUA

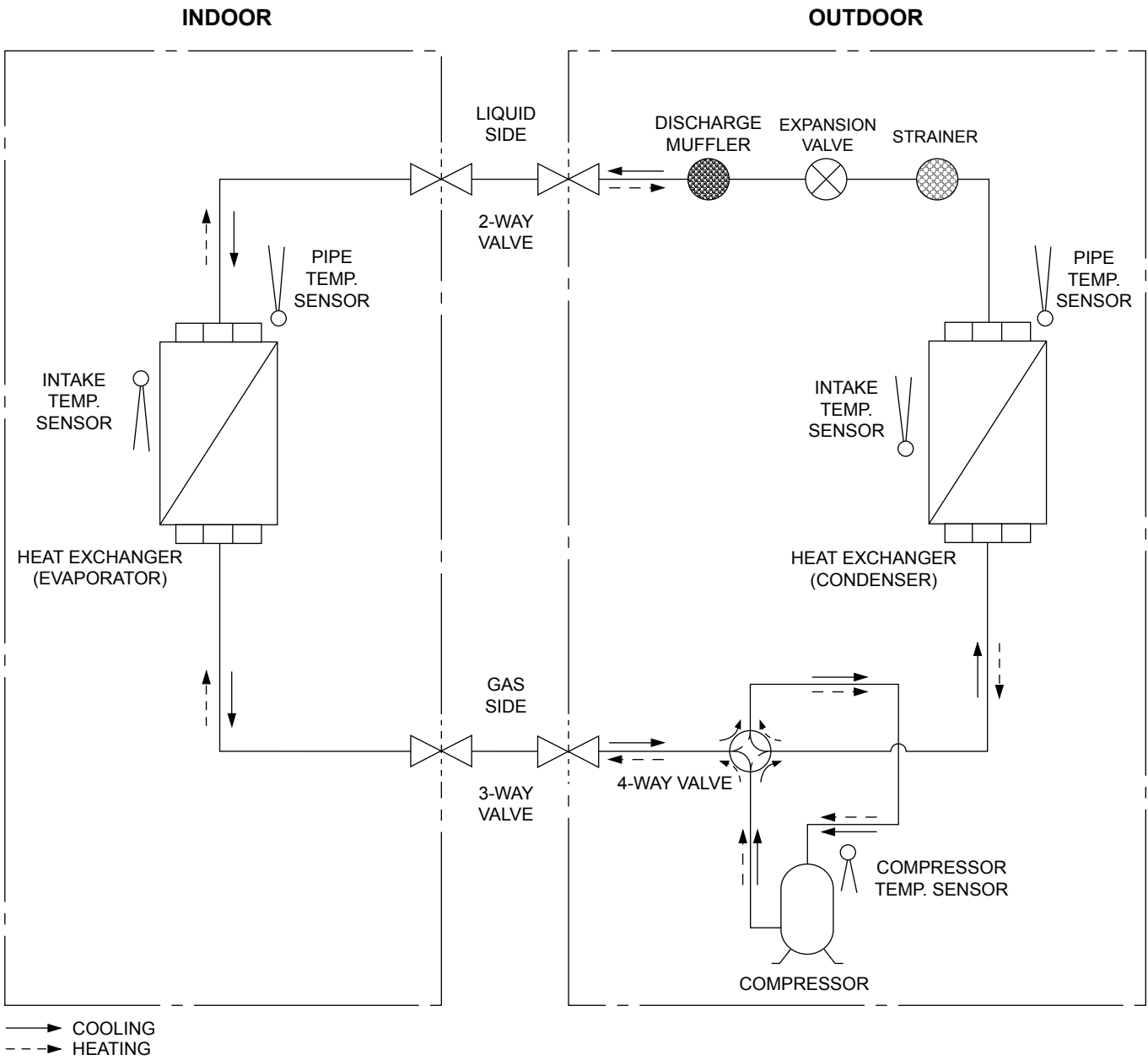

6.2 CU-RE18SKUA CU-RE24SKUA

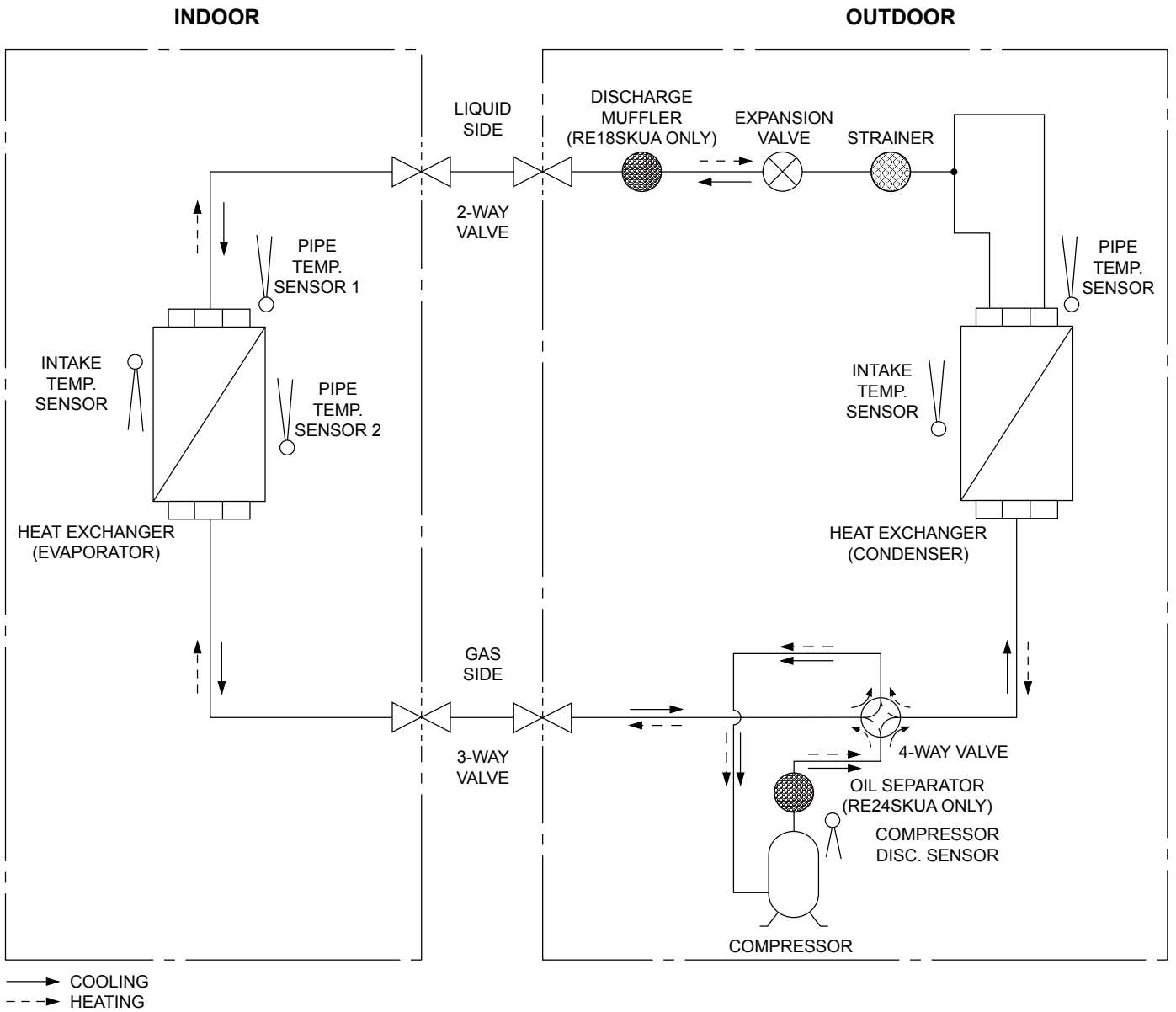

7. Block Diagram

7.1 CS-RE9SKUA CU-RE9SKUA CS-RE12SKUA CU-RE12SKUA

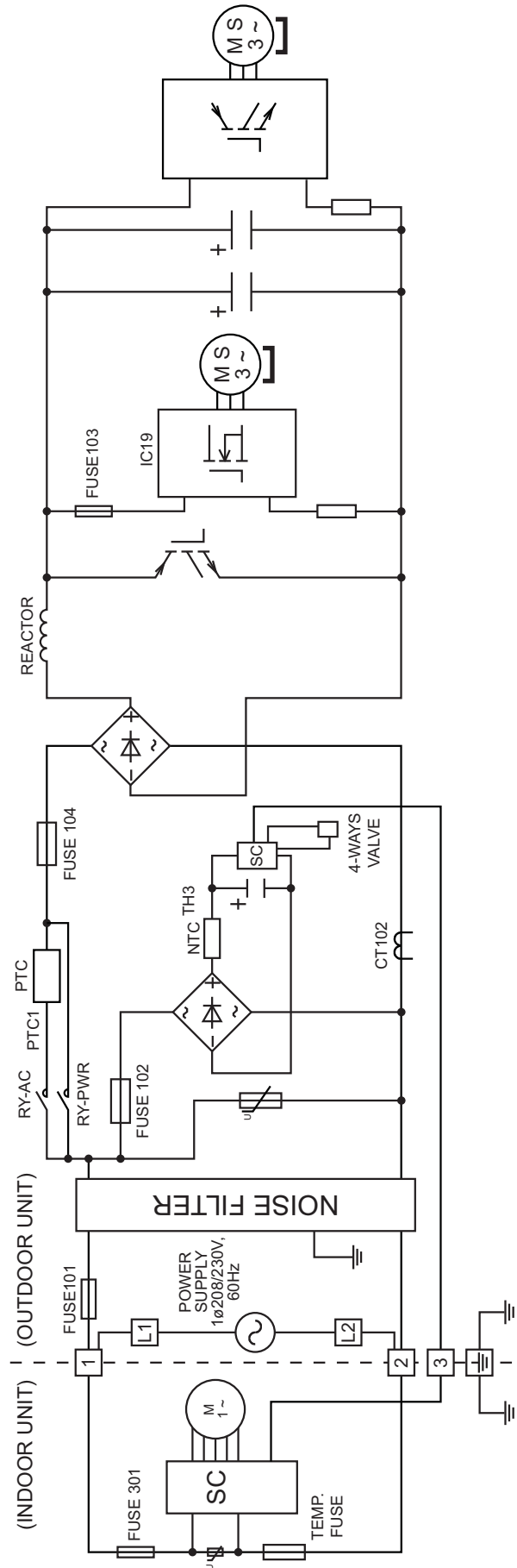

7.2 CS-RE18SKUA CU-RE18SKUA CS-RE24SKUA CU-RE24SKUA

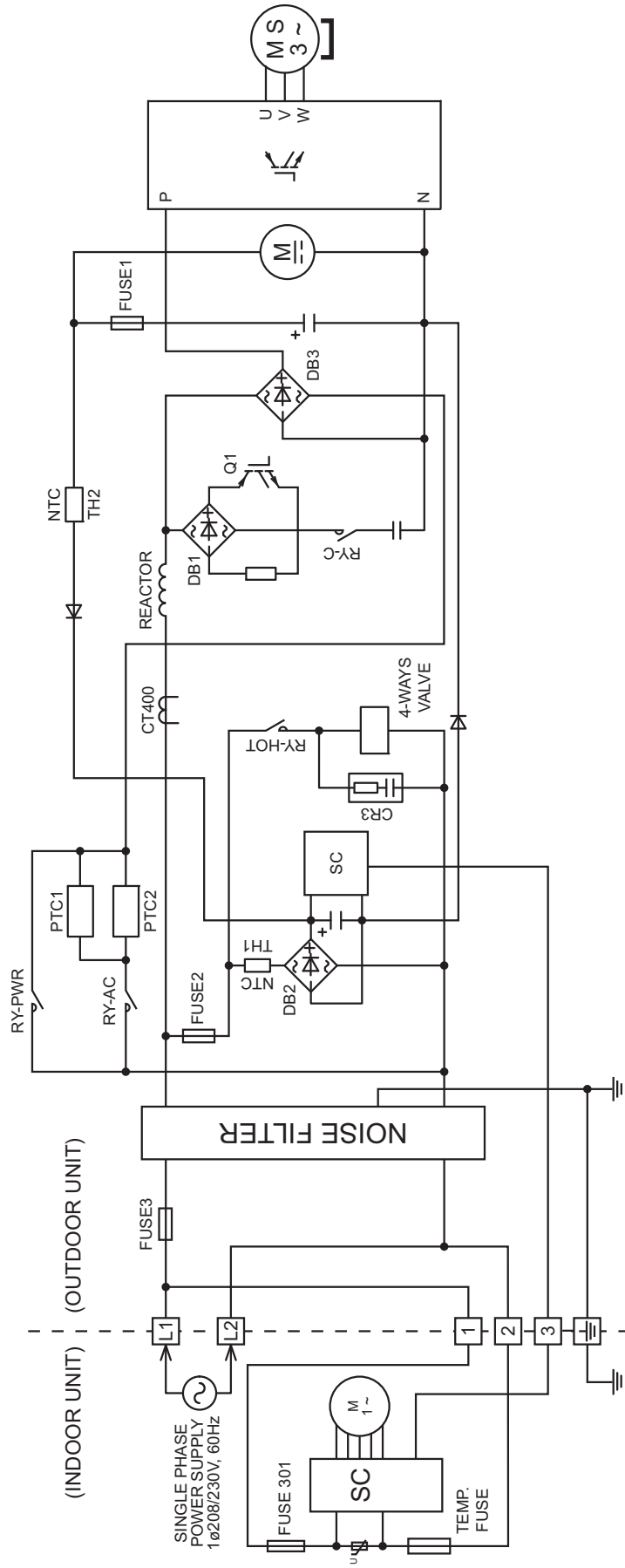

8. Wiring Connection Diagram

8.1 Indoor Unit

8.1.1 CS-RE9SKUA CS-RE12SKUA

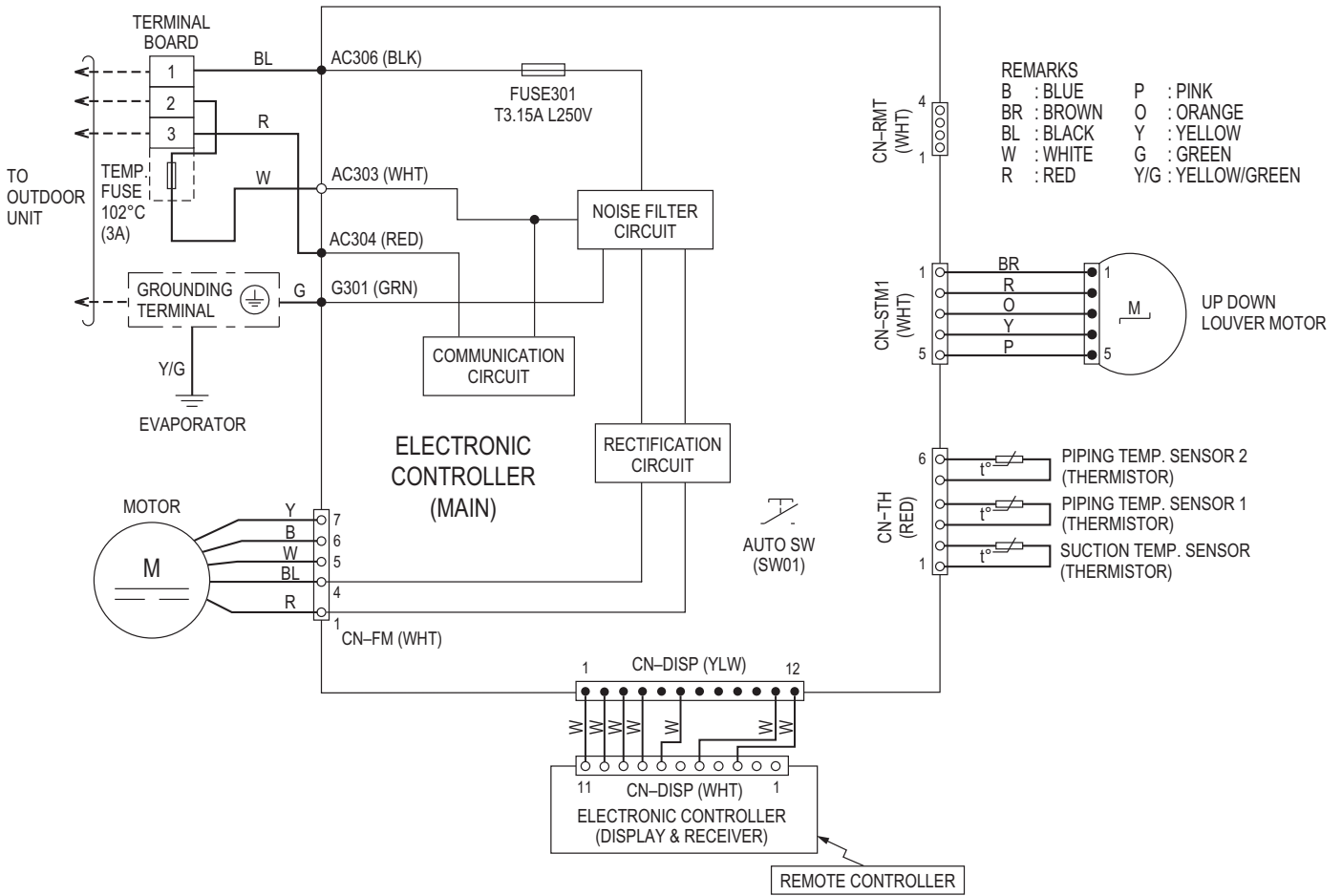

8.1.2 CS-RE18SKUA CS-RE24SKUA

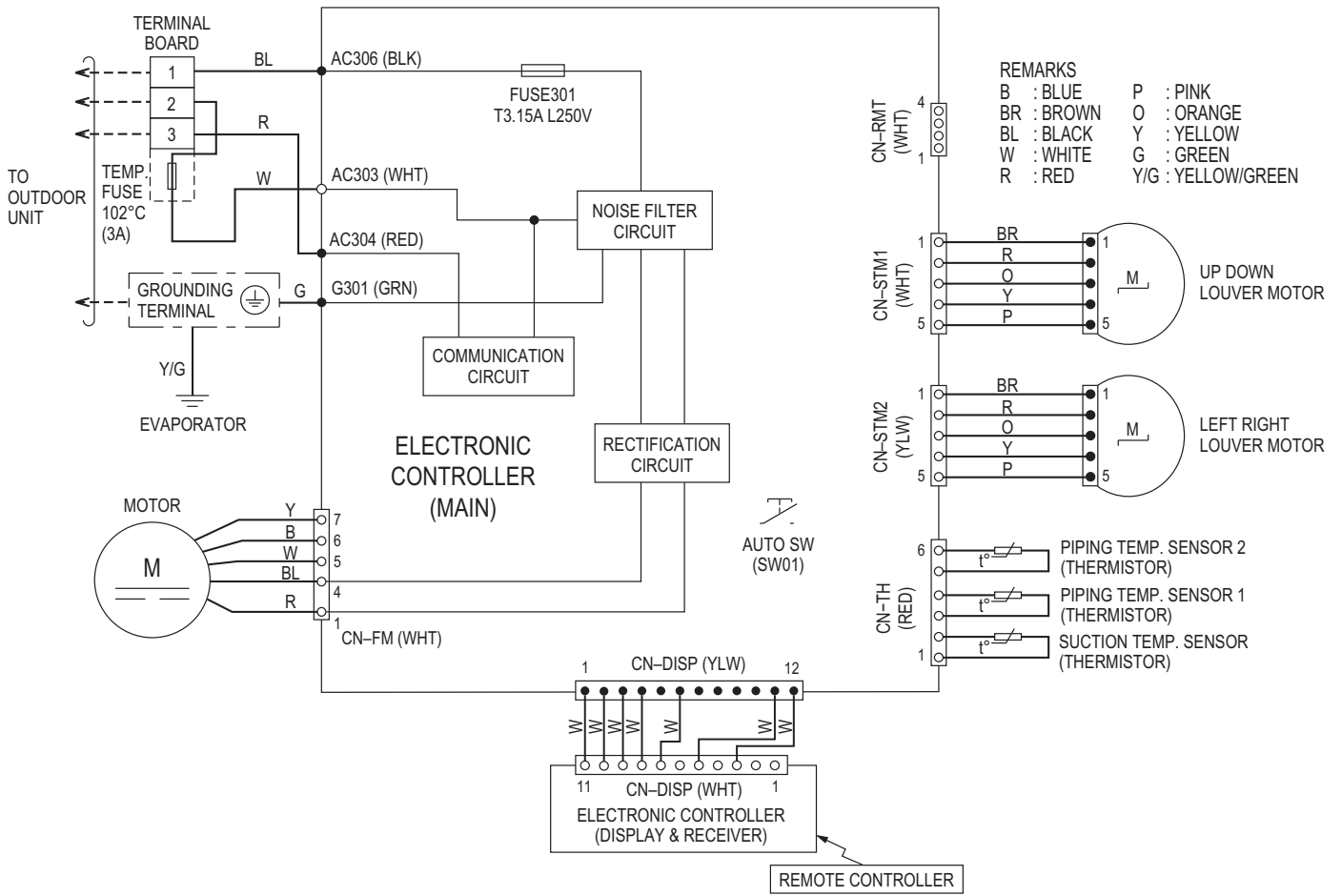

8.2 Outdoor Unit

8.2.1 CU-RE9SKUA CU-RE12SKUA

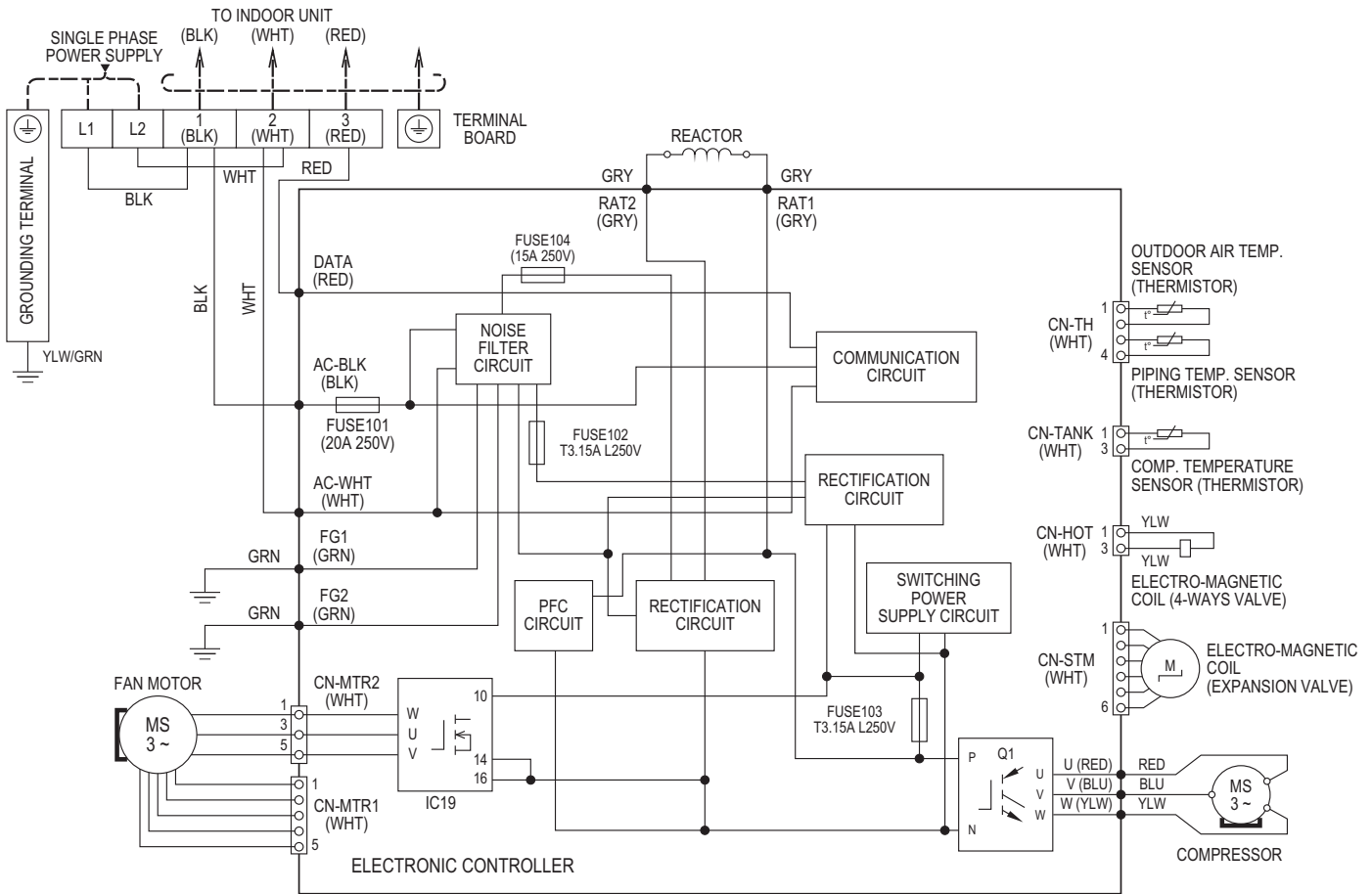

REMARKS

BLACK: (BLK) RED: (RED)
 WHITE: (WHT) BROWN: (BRW)
 YELLOW: (YLW) GREEN: (GRN)
 ORANGE: (ORG) GRAY: (GRY)
 BLUE: (BLU) YELLOW/GREEN: (YLW/GRN)

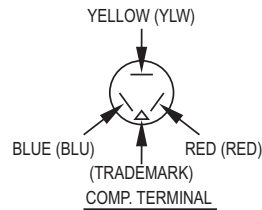

Resistance of Compressor Windings

MODEL	CU-RE9RKUA / CU-RE12RKUA
CONNECTION	5RS102XBC21
U-V	0.858 Ω
U-W	0.858 Ω
V-W	0.858 Ω

Note: Resistance at 20°C of ambient temperature.

8.2.2 CU-RE18SKUA CU-RE24SKUA

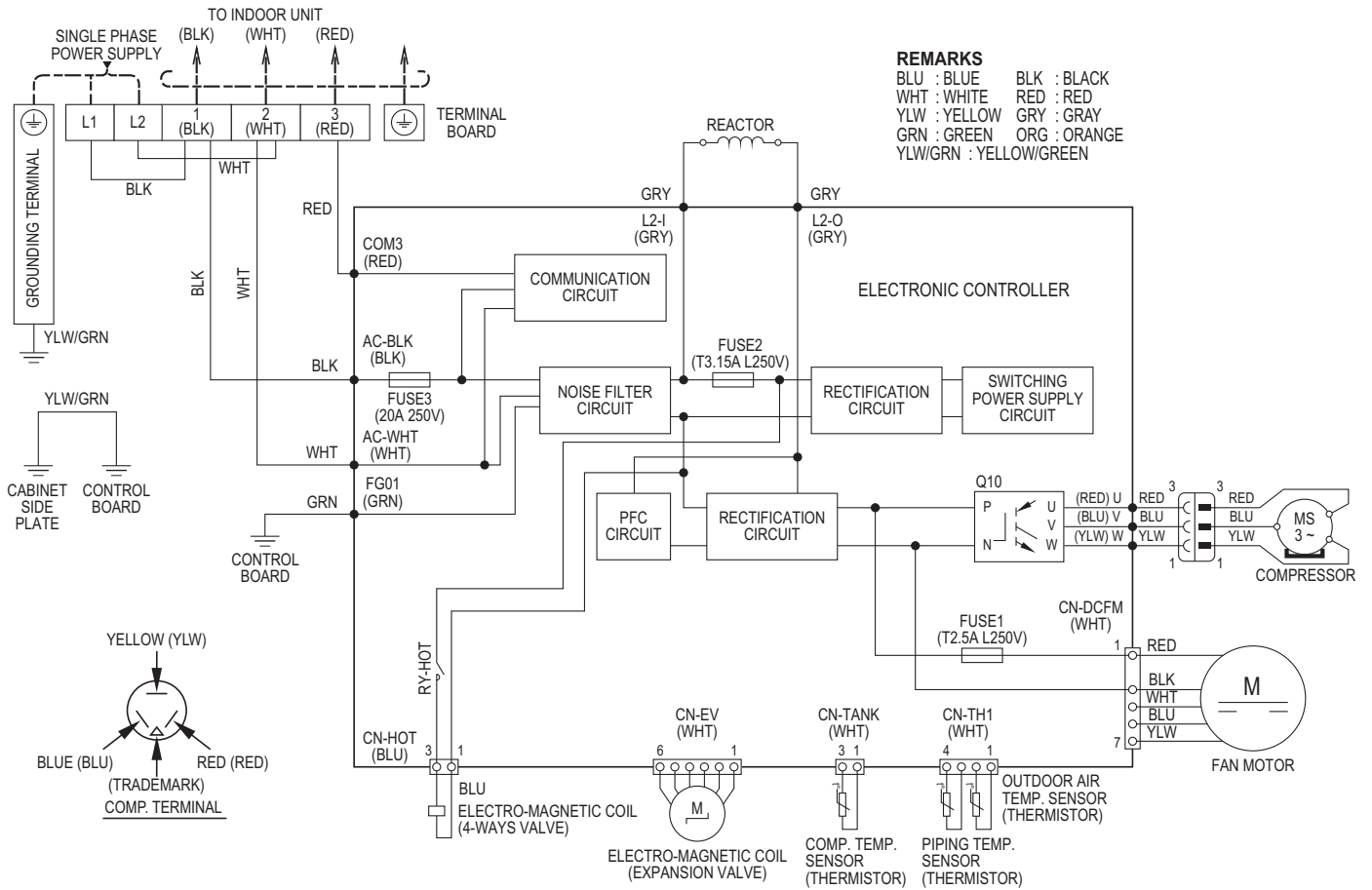

Resistance of Compressor Windings

MODEL	CU-RE18RKUA / CU-RE24RKUA
CONNECTION	5RD132XBA21
U-V	1.897 Ω
U-W	1.907 Ω
V-W	1.882 Ω

Note: Resistance at 20°C of ambient temperature.

9. Electronic Circuit Diagram

9.1 Indoor Unit

9.1.1 CS-RE9SKUA CS-RE12SKUA

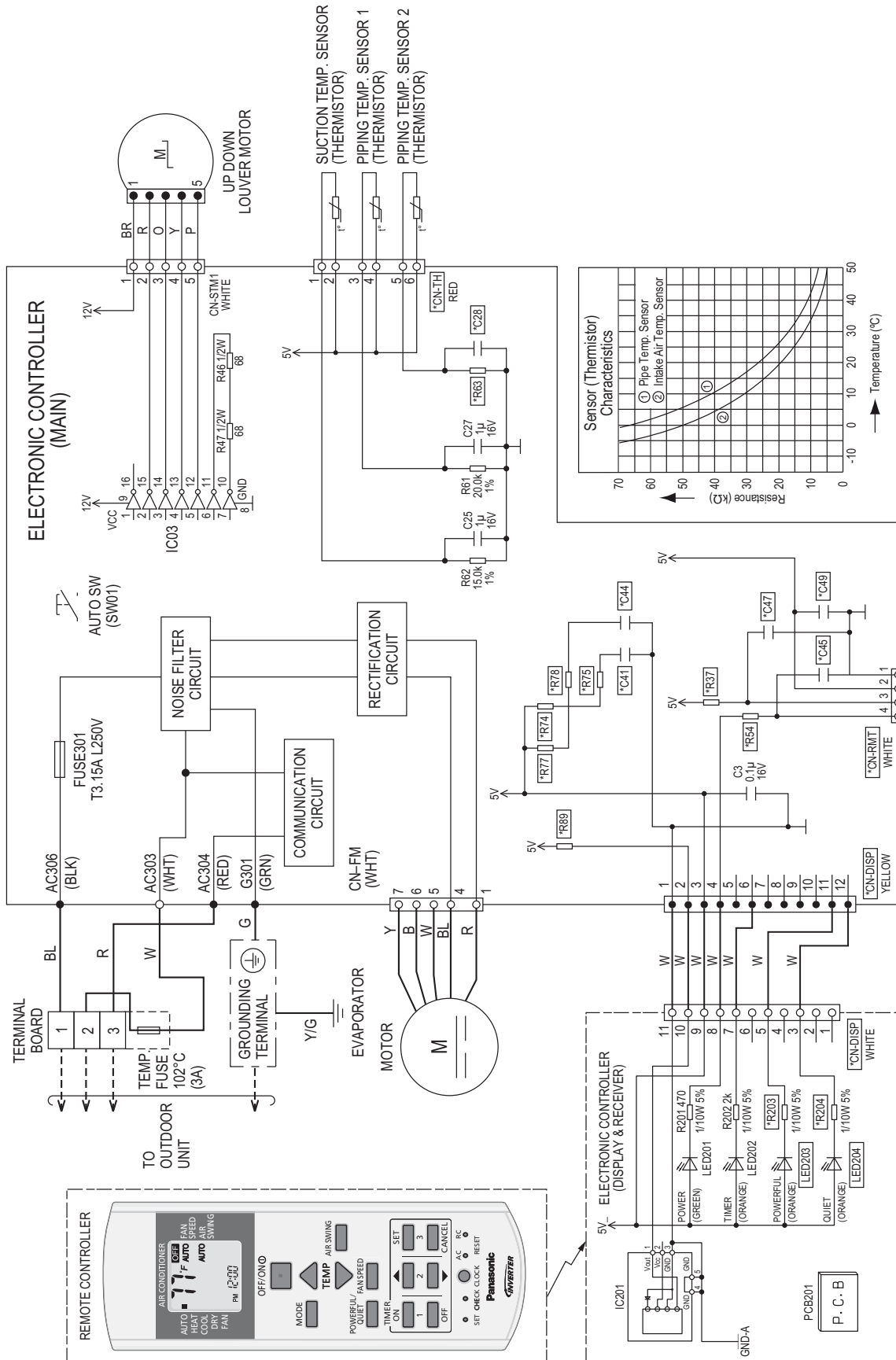

9.1.2 CS-RE18SKUA CS-RE24SKUA

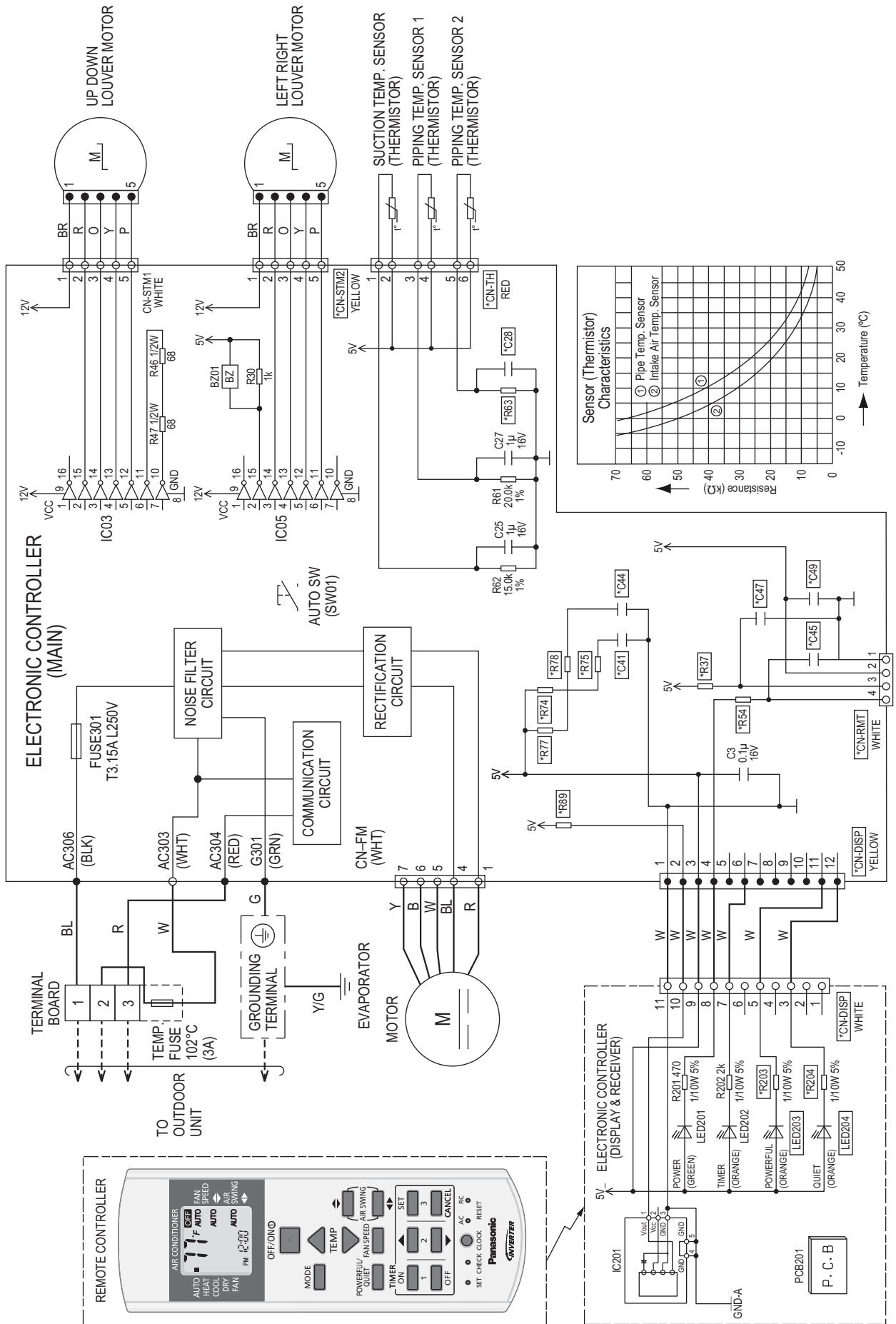

9.2 Outdoor Unit

9.2.1 CU-RE9SKUA CU-RE12SKUA

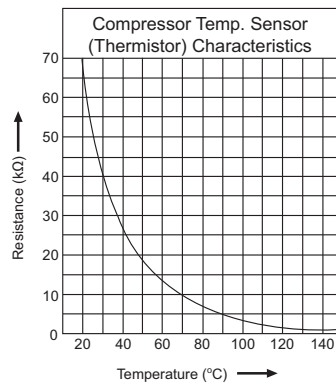
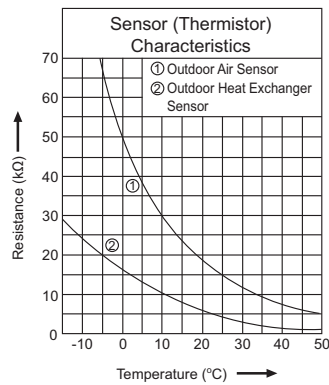
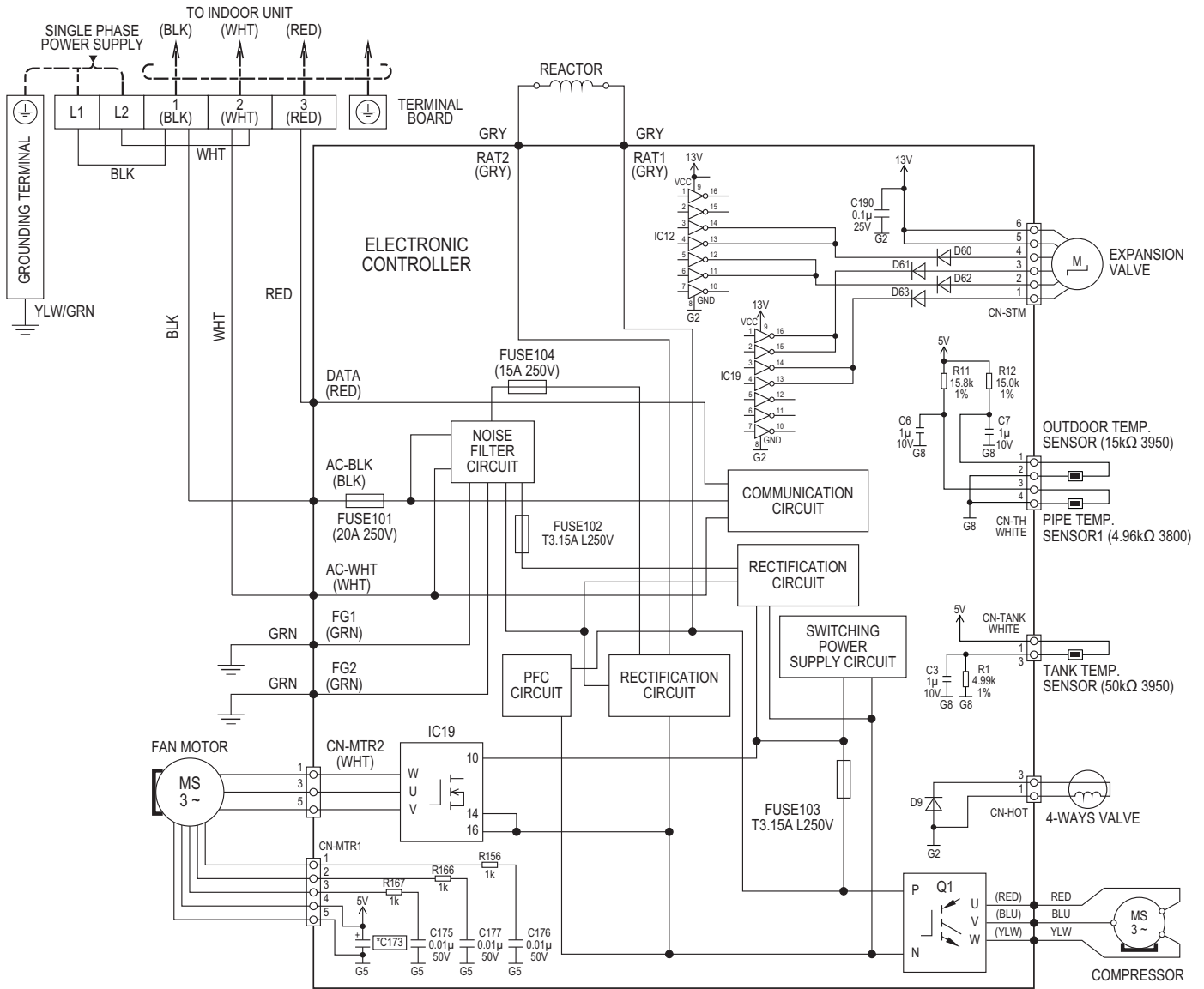

9.2.2 CU-RE18SKUA CU-RE24SKUA

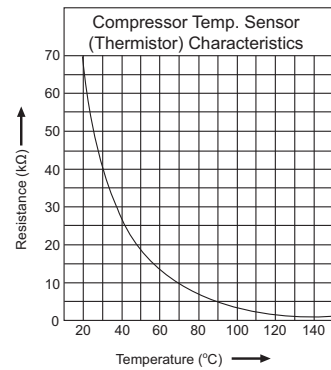
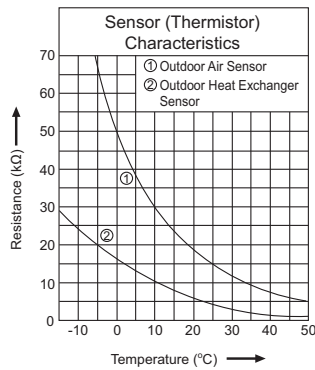
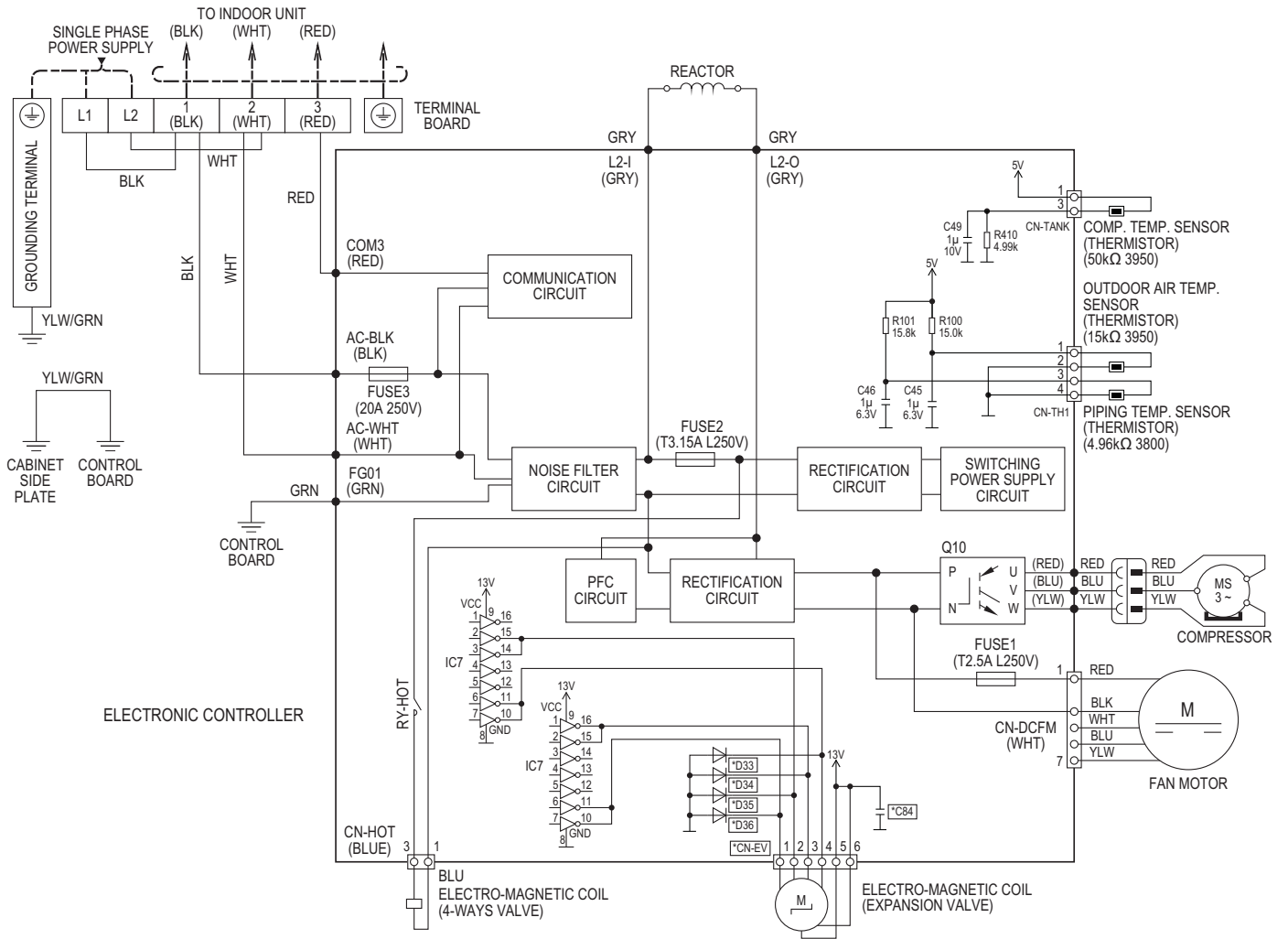

10. Printed Circuit Board

10.1 Indoor Unit

10.1.1 Main Printed Circuit Board

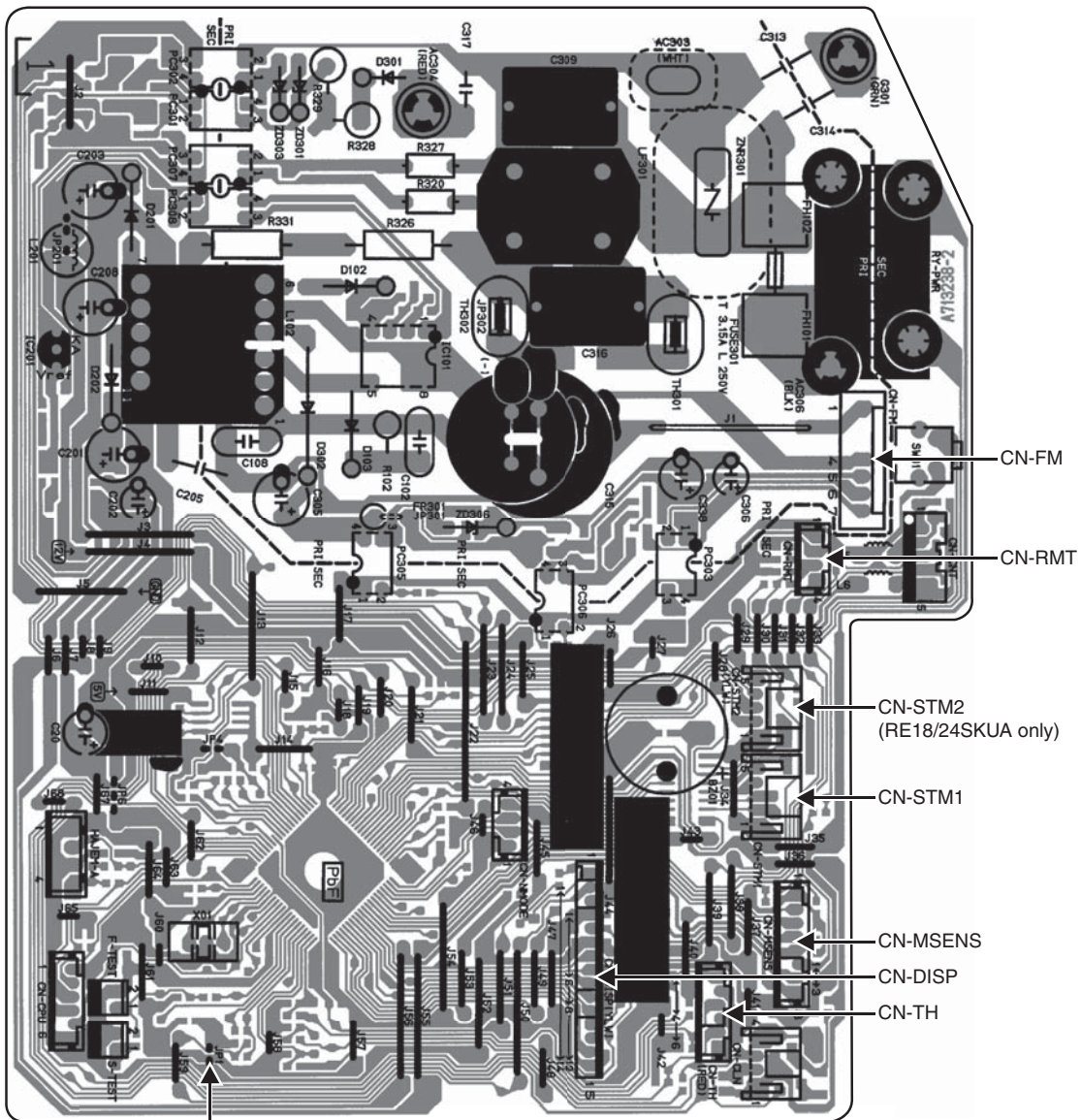

JP1 (Random Auto Restart enable/disable)

10.1.2 Indicator Printed Circuit Board

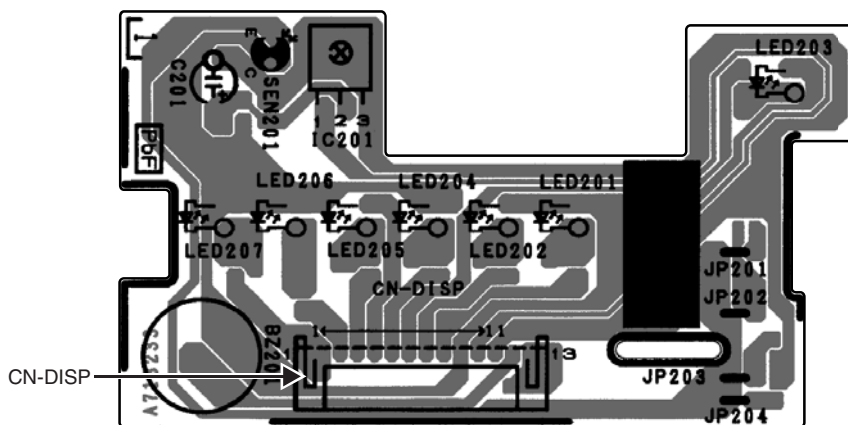

10.2.1.2 CU-RE18SKUA CU-RE24SKUA

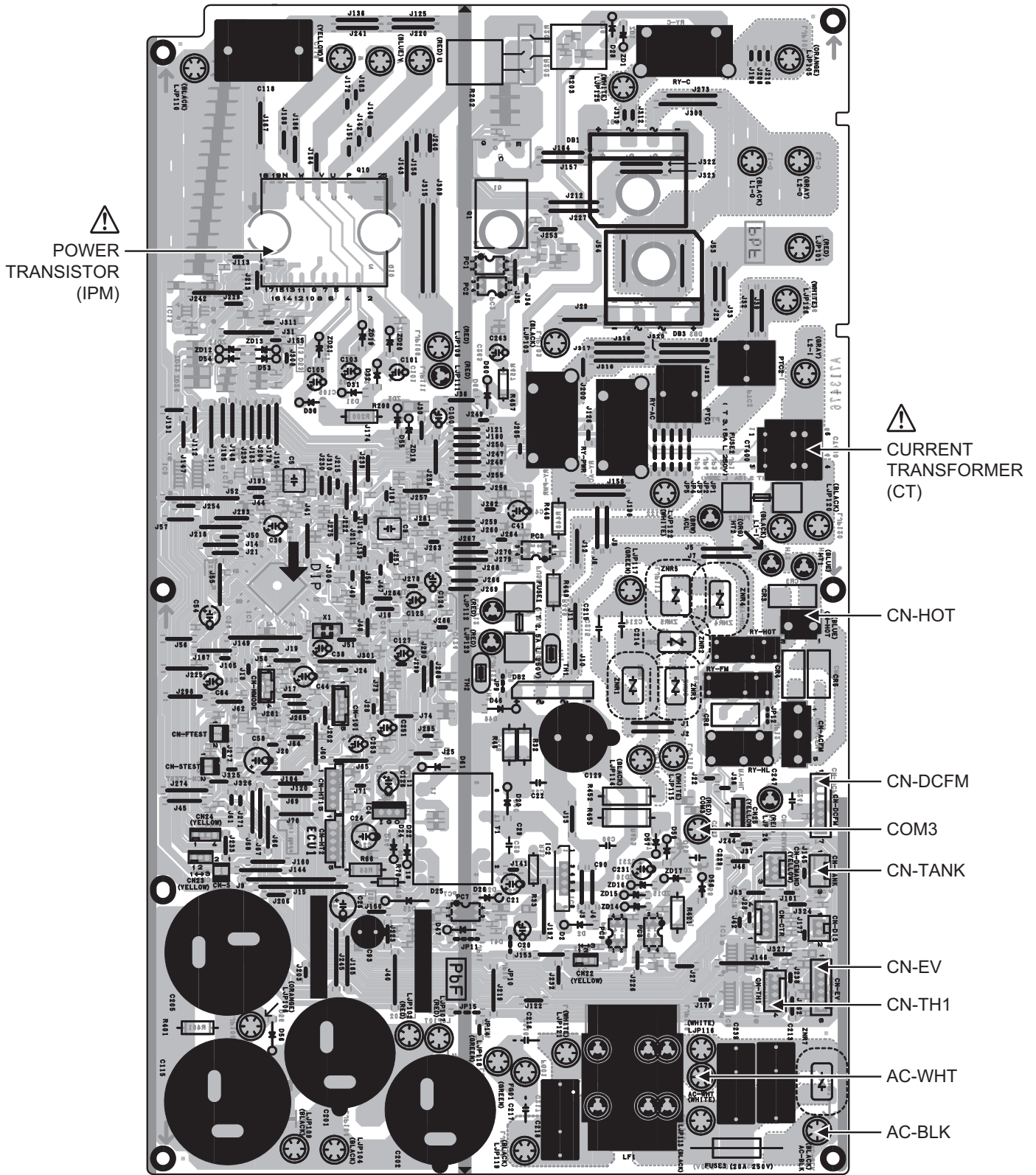

11. Installation Instruction (RE9SKUA and RE12SKUA)

11.1 Select the Best Location

11.1.1 Indoor Unit

- Do not install the unit in excessive oil fume area such as kitchen, workshop and etc.
- There should not be any heat source or steam near the unit.
- There should not be any obstacles blocking the air circulation.
- A place where air circulation in the room is good.
- A place where drainage can be easily done.
- A place where noise prevention is taken into consideration.
- Do not install the unit near the door way.
- Ensure the spaces indicated by arrows from the wall, ceiling, fence or other obstacles.
- Recommended installation height for indoor unit shall be at least 8 ft (2.4 m).

11.1.2 Outdoor Unit

- If an awning is built over the unit to prevent direct sunlight or rain, be careful that heat radiation from the condenser is not obstructed.
- There should not be any animal or plant which could be affected by hot air discharged.
- Keep the spaces indicated by arrows from wall, ceiling, fence or other obstacles.
- Do not place any obstacles which may cause a short circuit of the discharged air.
- If piping length is over the [piping length for additional gas], additional refrigerant should be added as shown in the table.
- Recommended installation height for outdoor unit should be above the seasonal snow level.
- Be careful not to locate outdoor unit directly under a roof line where falling snow or ice can cause damage or dripping water can increase ice accumulation and defrost cycles.

Model	Capacity (Btu/h)	Piping size		Std. Length	Max. Elevation	Min. Piping Length	Max. Piping Length	Additional Refrigerant	Piping Length for add. gas
		Gas	Liquid						
RE9SKUA	9000	3/8" (9.52 mm)	1/4" (7.5 mm)	24.6 ft (7.5 m)	49.2 ft (15 m)	9.8 ft (3 m)	49.2 ft (15 m)	0.2 oz/ft (20 g/m)	24.6 ft (7.5 m)
RE12SKUA	12000	1/2" (9.52 mm)	3/8" (9.52 mm)	24.6 ft (7.5 m)	49.2 ft (15 m)	9.8 ft (3 m)	49.2 ft (15 m)	0.2 oz/ft (20 g/m)	24.6 ft (7.5 m)

Example: For RE9SKUA

If the unit is installed at 32.8 ft (10 m) distance, the quantity of additional refrigerant should be 1.64 oz (50 g) (32.8 - 24.6) ft x 0.2 oz/ft = 1.64 oz. ((10 - 7.5) m x 20 g/m = 50 g).

11.1.3 Indoor/Outdoor Unit Installation Diagram

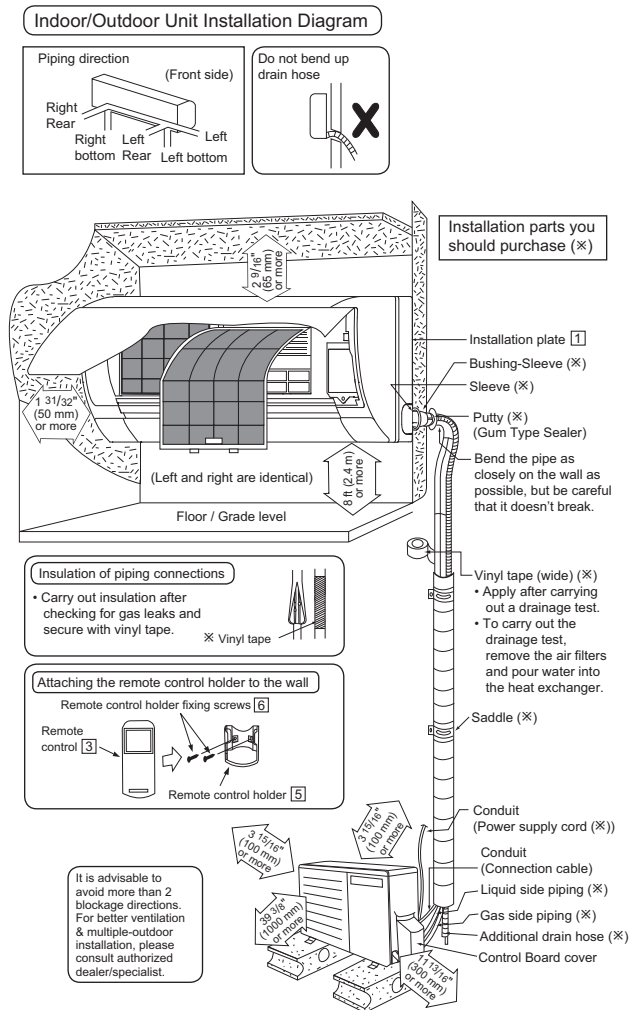

- This illustration is for explanation purposes only. The indoor unit will actually face a different way.

11.2 Indoor Unit

11.2.1 How to Fix Installation Plate

The mounting wall shall be strong and solid enough to prevent it from the vibration.

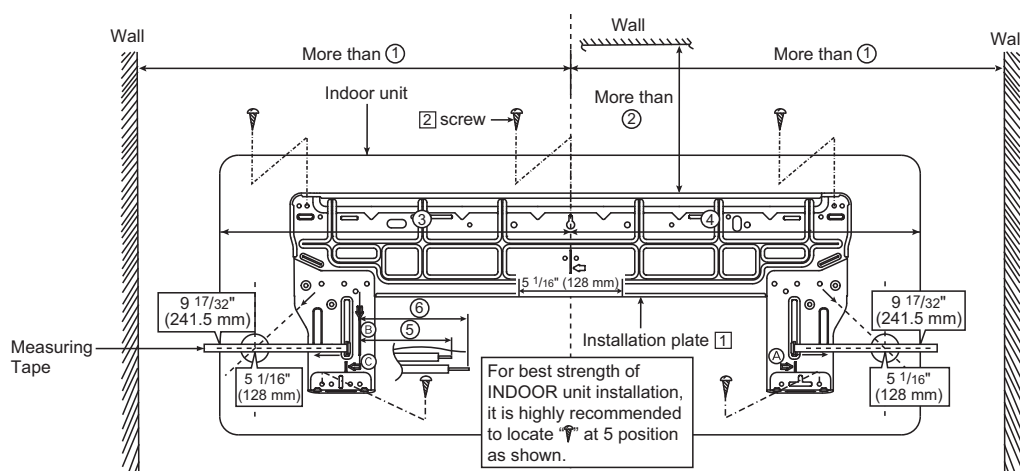

Model	Dimension					
	①	②	③	④	⑤	⑥
RE9SKUA, RE12SKUA	19 9/32" 490 mm	3 7/32" 82 mm	17 9/32" 439 mm	17" 432 mm	1 11/16" 43 mm	3 3/4" 95 mm

The center of installation plate should be at more than ① at right and left of the wall.

The distance from installation plate edge to ceiling should more than ②.

From installation plate left edge to unit's left side is ③.

From installation plate right edge to unit's right side is ④.

Ⓑ : For left side piping, piping connection for liquid should be about ⑤ from this line.

: For left side piping, piping connection for gas should be about ⑥ from this line.

- 1 Mount the installation plate on the wall with 5 screws or more (at least 5 screws).
(If mounting the unit on the concrete wall, consider using anchor bolts.)
 - Always mount the installation plate horizontally by aligning the marking-off line with the thread and using a level gauge.
- 2 Drill the piping plate hole with $\varnothing 2 \frac{3}{4}$ " ($\varnothing 70$ mm) hole-core drill.
 - Line according to the left and right side of the installation plate. The meeting point of the extended line is the center of the hole. Another method is by putting measuring tape at position as shown in the diagram above. The hole center is obtained by measuring the distance namely $5 \frac{1}{16}$ " (128 mm) for left and right hole respectively.
 - Drill the piping hole at either the right or the left and the hole should be slightly slanting to the outdoor side.

11.2.2 To Drill a Hole in the Wall and Install a Sleeve of Piping

- 1 Insert the piping sleeve to the hole.
- 2 Fix the bushing to the sleeve.
- 3 Cut the sleeve until it extrudes about $19/32$ " (15 mm) from the wall.

⚠ CAUTION

ⓘ When the wall is hollow, please be sure to use the sleeve for tube assembly to prevent dangers caused by mice biting the connection cable.

- 4 Finish by sealing the sleeve with putty or caulking compound at the final stage.

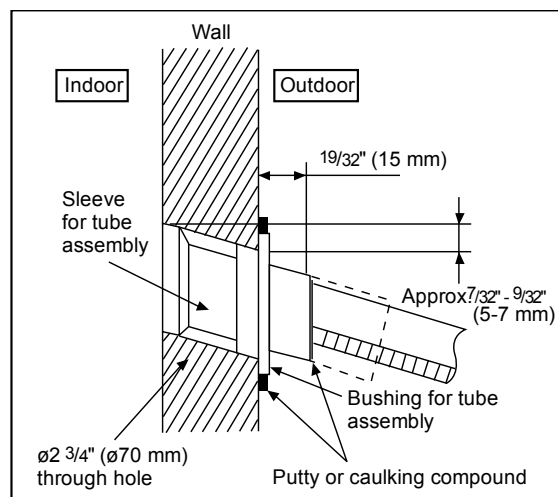

11.2.3 Indoor Unit Installation

- Do not turn over the unit without it's shock absorber during pull out the piping. It may cause intake grille damage.
- Use shock absorber during pull out the piping to protect the intake grille from damage.

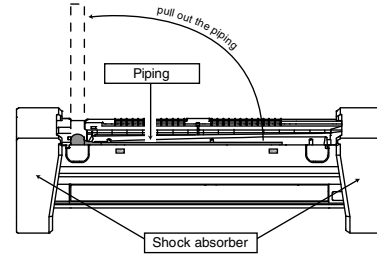
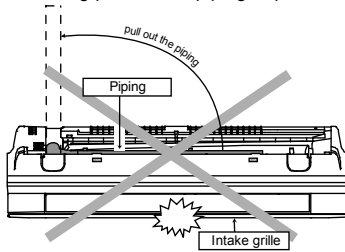

11.2.3.1 For the right rear piping

Step-1 Pull out the Indoor piping

Step-2 Install the Indoor Unit

Step-3 Secure the Indoor Unit

Step-4 Insert the connection cable

11.2.3.2 For the right bottom piping

Step-1 Pull out the Indoor piping

Step-2 Install the Indoor Unit

Step-3 Insert the connection cable

Step-4 Secure the Indoor Unit

11.2.3.3 For the embedded piping

Step-1 Replace the drain hose

Step-2 Bend the embedded piping

- Use a spring bender or equivalent to bend the piping so that the piping is not crushed.

Step-3 Pull the connection cable into Indoor Unit

- The inside and outside connection cable can be connected without removing the front grille.

Step-4 Cut and flare the embedded piping

- When determining the dimensions of the piping, slide the unit all the way to the left on the installation plate.
- Refer to the section "Cutting and flaring the piping".

Step-5 Install the Indoor Unit

Step-6 Connect the piping

- Please refer to "Connecting the piping" column in outdoor unit section. (Below steps are done after connecting the outdoor piping and gas-leakage confirmation.)

Step-7 Insulate and finish the piping

- Please refer to "Insulation of piping connection" column as mentioned in indoor/outdoor unit installation.

Step-8 Secure the Indoor Unit

Right Rear piping

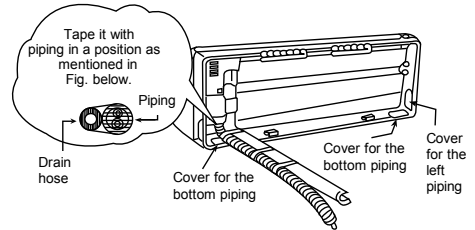

How to keep the cover

In case of the cover is cut, keep the cover at the rear of chassis as shown in the illustration for future reinstallation. (Left, right and 2 bottom covers for piping.)

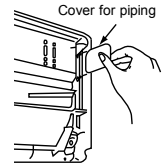

Right and Right Bottom piping

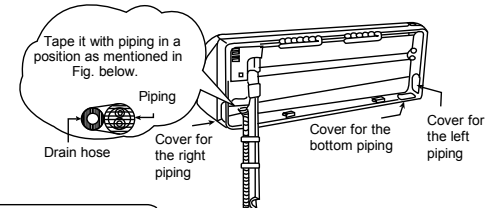

Install the indoor unit

Hook the indoor unit onto the upper portion of installation plate. (Engage the indoor unit with the upper edge of the installation plate). Ensure the hooks are properly seated on the installation plate by moving it in left and right.

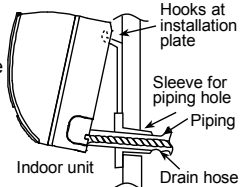

Secure the Indoor Unit

Press the lower left and right side of the unit against the installation plate until hooks engages with their slot (sound click).

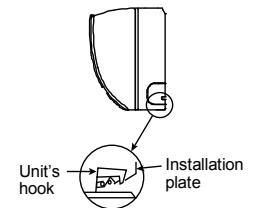

Insert the connection cable

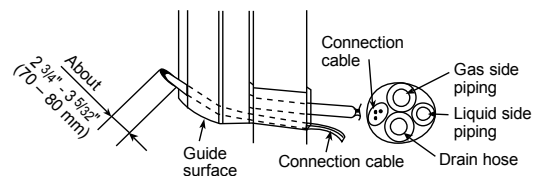

To take out the unit, push the [PUSH] marking at the bottom unit, and pull it slightly towards you to disengage the hooks from the unit.

(This can be used for left rear piping and bottom piping also.)

Replace the drain hose

Rear view for left piping installation

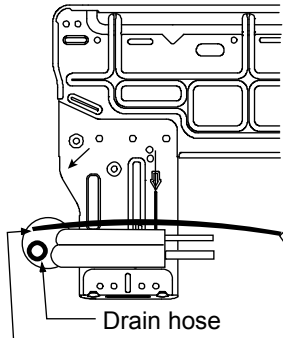
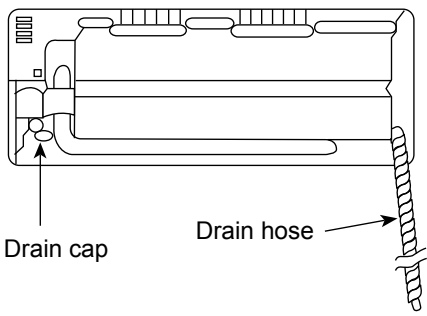

Adjust the piping slightly downwards.

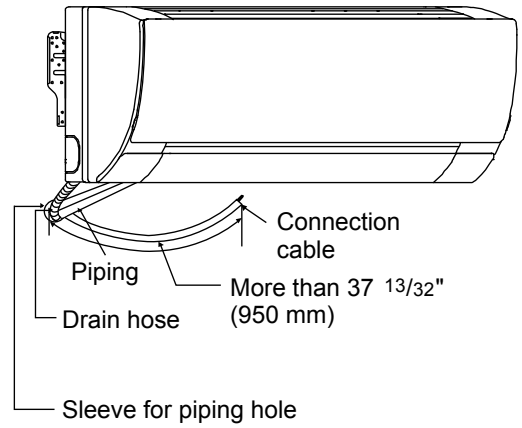

- How to pull the piping and drain hose out, in case of embedded piping.

Apply putty or caulking material to seal the wall opening.

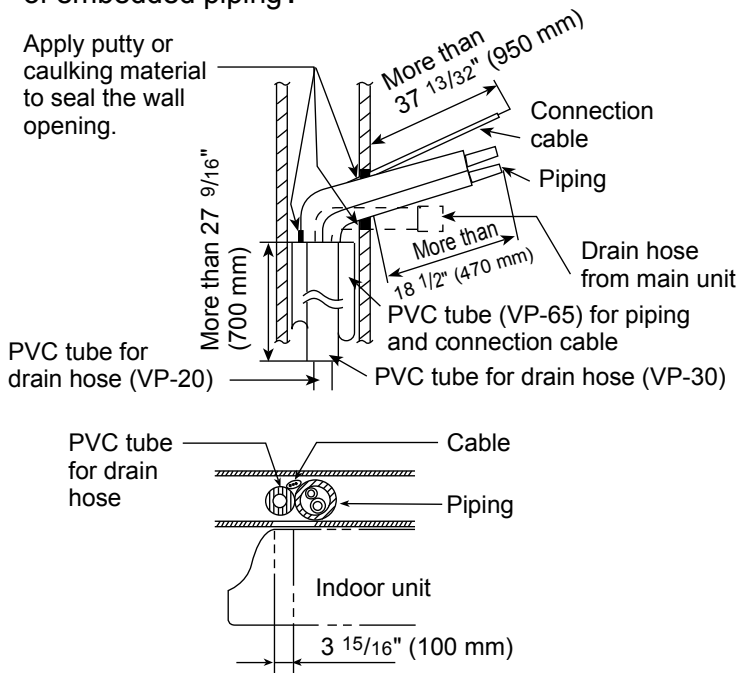

- How to insert the connection cable and drain hose in the case of left piping.

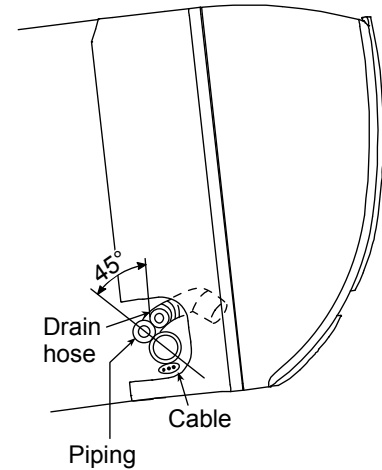

(For right piping, follow the same procedure)

Drain hose adapter 8 usage

- Join indoor drain hose to 3/4" (20 mm) nominal PVC pipe size by using drain hose adapter 8 when necessary.

Remarks :

Make sure indoor unit drain hose & 3/4" (20 mm) nominal PVC pipe are fully inserted to drain hose adapter 8.

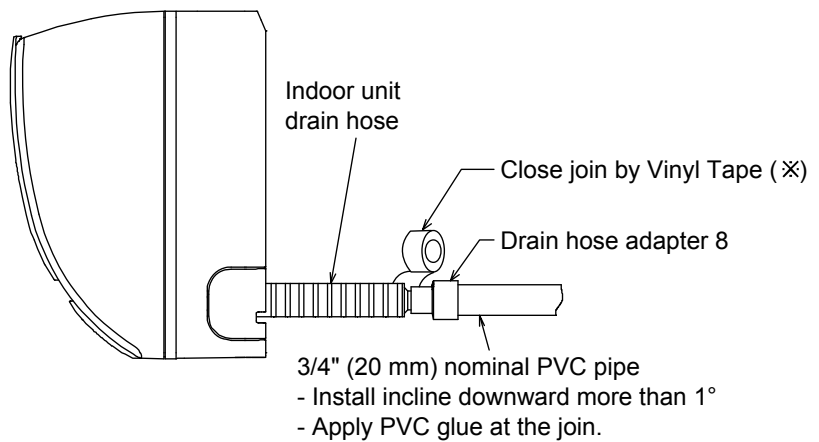

11.2.4 Connect the Cable to the Indoor Unit

1. The inside and outside connection cable can be connected without removing the front grille.
2. Unscrew the conduit cover and fix the conduit connector to conduit cover with lock nut, then secure it against chassis.
3. Connection cable between indoor unit and outdoor unit should be UL listed or CSA approved 4 conductor wires minimum AWG16 in accordance with local electric codes.
 - o Ensure the colour of wires of outdoor unit and terminal number are the same as the indoor's respectively.

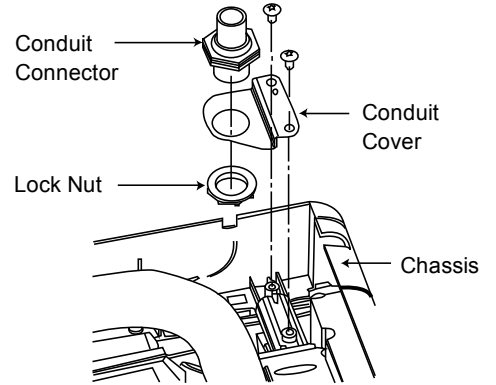

Rear Side of Indoor Unit

Terminals on the indoor unit	1	2	3	
Colour of wires (connection cable)				
Terminals on the outdoor unit	1	2	3	

WARNING
 This equipment must be properly earthed.

- o Earth lead wire shall be Yellow/Green (Y/G) in colour and shall be longer than other lead wires as shown in the figure for electrical safety in case of the slipping.

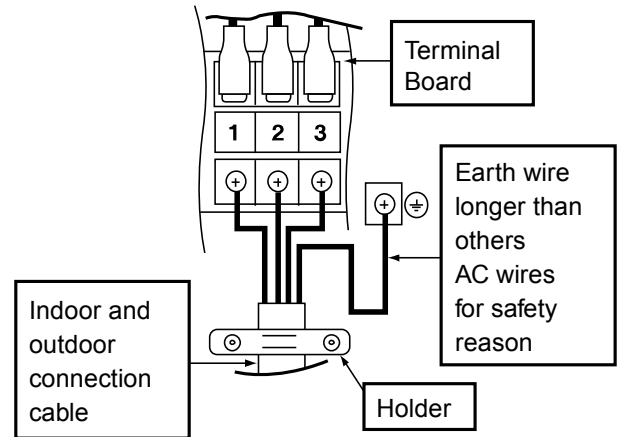

11.2.4.1 Wire Stripping, Connecting Requirement

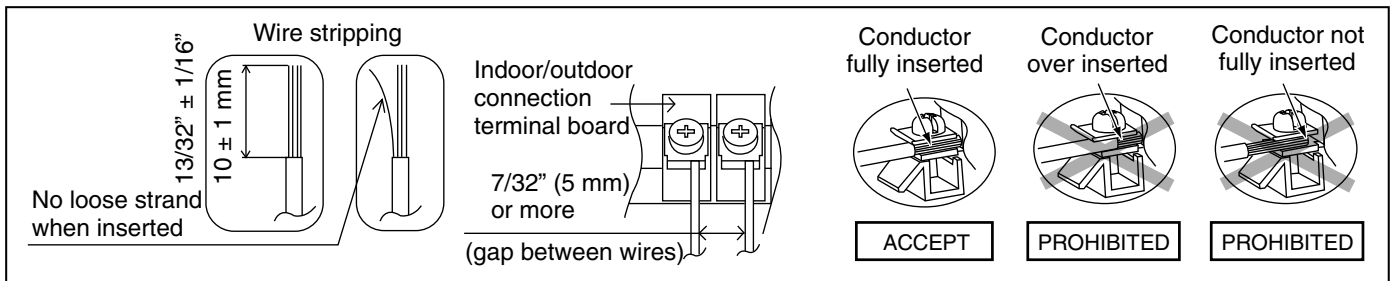

WARNING
RISK OF FIRE
 JOINING OF WIRES MAY CAUSE OVERHEATING AND FIRE.

Do not joint wires

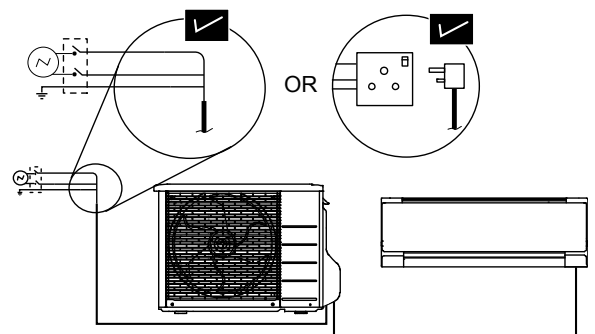
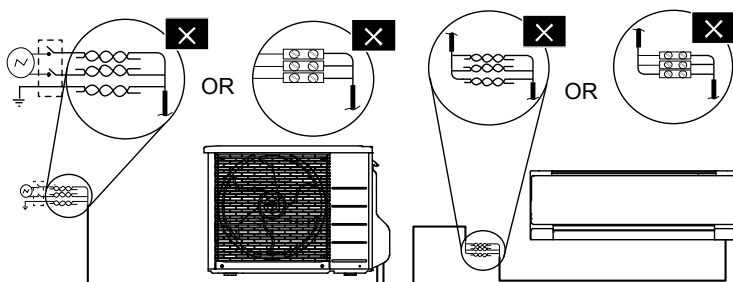

- ! Use complete wire without joining.
- ! Use approved socket and plug with earth pin.
- ! Wire connection in this area must follow to national wiring rules.

11.2.4.2 Cutting and flaring the piping

- 1 Please cut using pipe cutter and then remove the burrs.
- 2 Remove the burrs by using reamer. If burrs are not removed, gas leakage may be caused. Turn the piping end down to avoid the metal powder entering the pipe.
- 3 Please make flare after inserting the flare nut onto the copper pipes.

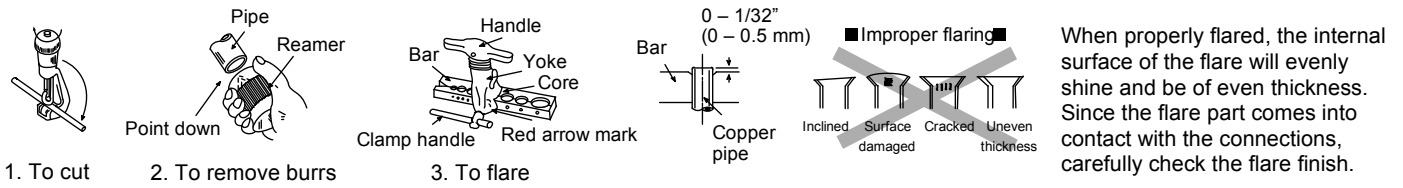

11.3 Outdoor Unit

11.3.1 Install the Outdoor Unit

- After selecting the best location, start installation according to Indoor/Outdoor Unit Installation Diagram.
 - Fix the unit on concrete or rigid frame firmly and horizontally with a bolt nut ($\varnothing 13/32"$ ($\varnothing 10$ mm)).
 - When installing at roof, please consider strong wind and earthquake.
Please fasten the installation stand firmly with bolt or nails.

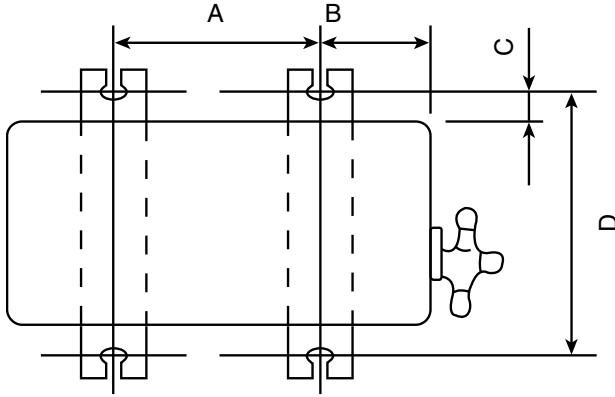

Model	A	B	C	D
RE9SKUA, RE12SKUA	22-7/16" (570 mm)	4-1/8" (105 mm)	23/32" (18.5 mm)	12-19/32" (320 mm)

11.3.2 Connect the Piping

11.3.2.1 Connecting the piping to indoor

Please make flare after inserting flare nut (locate at joint portion, of tube assembly) onto the copper pipe. (In case of using long piping)

Connect the piping

- Align the center of piping and sufficiently tighten the flare nut with fingers.
- Further tighten the flare nut with torque wrench in specified torque as stated in the table.

11.3.2.2 Connecting the piping to outdoor

Decide piping length and then cut by using pipe cutter. Remove burrs from cut edge.

Make flare after inserting the flare nut (locate at valve) onto the copper pipe.

Align center of piping to valves and then tighten with torque wrench to the specified torque as stated in the table.

11.3.2.3 Gas Leak Checking

Pressure test to system to 400 PSIG with dry nitrogen, in stages. Thoroughly leak check the system. If the pressure holds, release the nitrogen and proceed to section 11.3.3.

Do not over tighten, over tightening may cause gas leakage.	
Piping size	Torque
1/4" (6.35 mm)	13.3 lbf.ft [18 N•m (1.8 kgf•m)]
3/8" (9.52 mm)	31.0 lbf.ft [42 N•m (4.3 kgf•m)]
1/2" (12.7 mm)	40.6 lbf.ft [55 N•m (5.6 kgf•m)]
5/8" (15.88 mm)	47.9 lbf.ft [65 N•m (6.6 kgf•m)]
3/4" (19.05 mm)	73.8 lbf.ft [100 N•m (10.2 kgf•m)]

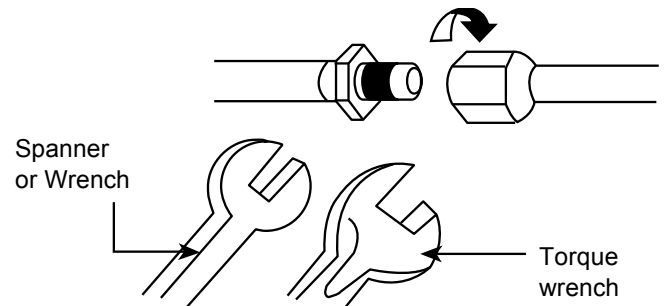

11.3.3 Evacuation of the Equipment

WHEN INSTALLING AN AIR CONDITIONER, BE SURE TO EVACUATE THE AIR INSIDE THE INDOOR UNIT AND PIPES in the following procedures.

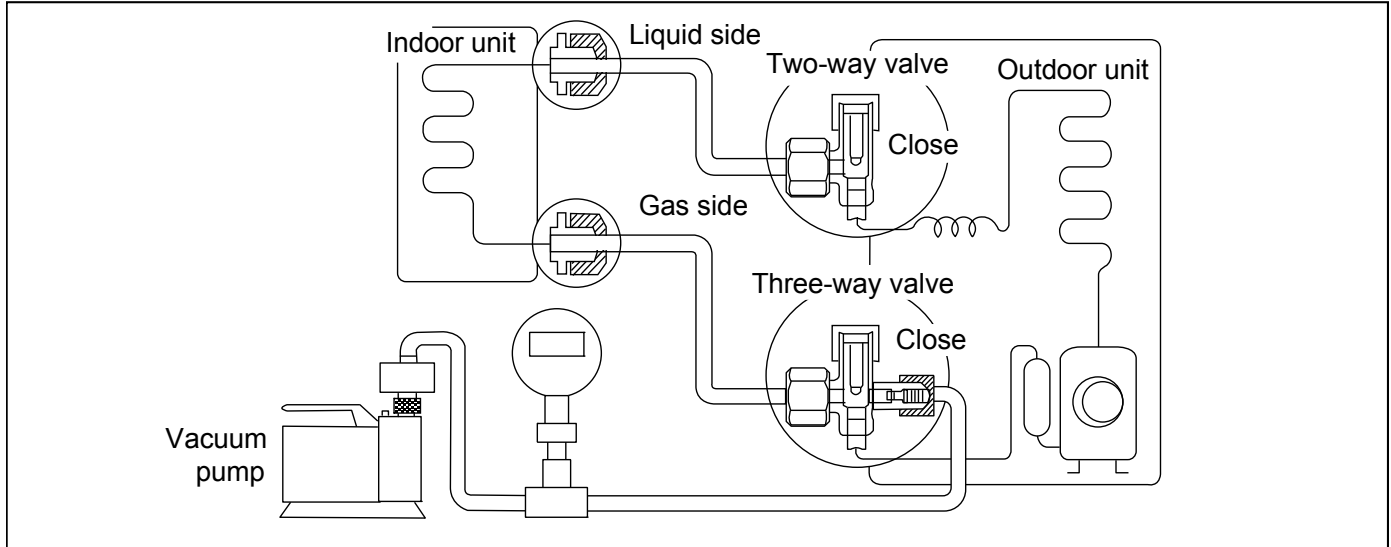

1. Connect a charging hose with a push pin to the Low side of a charging set and the service port of the 3-way valve.
2. Connect the micron gauge between vacuum pump and service port of outdoor units.
3. Turn on the power switch of the vacuum pump and make sure that connect digital micron gauge and to pull down to a value of 500 microns.
4. To make sure micron gauge a value 500 microns and close the low side valve of the charging set and turn off the vacuum pump.
5. Disconnect the vacuum pump house from the service port of the 3-way valve.
6. Tighten the service port caps of the 3-way valve at a torque of 13.3 lbf.ft (18 N•m) with a torque wrench.
7. Remove the valve caps of both of the 2-way valve and 3-way valve. Position both of the valves to "Open" using a hexagonal wrench (5/32" (4 mm)).
8. Mount valve caps onto the 2-way valve and the 3-way valve.
 - o Be sure to check for gas leakage.

- If micron gauge value does not descend 500 microns, take the following measures:
 - If the leak stops when the piping connections are tightened further, continue working from step ③.
 - If the leak does not stop when the connections are retightened, repair location of leak.
 - Do not release refrigerant during piping work for installation and reinstallation.
 - Be careful with the liquid refrigerant, it may cause frostbite.

11.3.3.1 Connect the Cable to the Outdoor Unit

1. Remove Top panel.
2. Remove Control Board Cover (Resin and Metal).
3. Remove Plugs.
4. Fix the conduit connectors to the knockout holes with lock-nuts, then secure them against the side panel.
5. All wires pass through conduits.
6. Connection cable between indoor unit and outdoor unit should be UL listed or CSA approved 4 conductor wires minimum AWG16 in accordance with local electric codes.
7. Wire connection to the power supply (208/230V 60Hz) through circuit breaker.
 - o Connect the UL listed or CSA approved wires minimum AWG14 to the terminal board, and connect the other end of the wires to ELCB / GFCI.
8. Connect the power supply cord and connection cable between indoor unit and outdoor unit according to the diagram below.

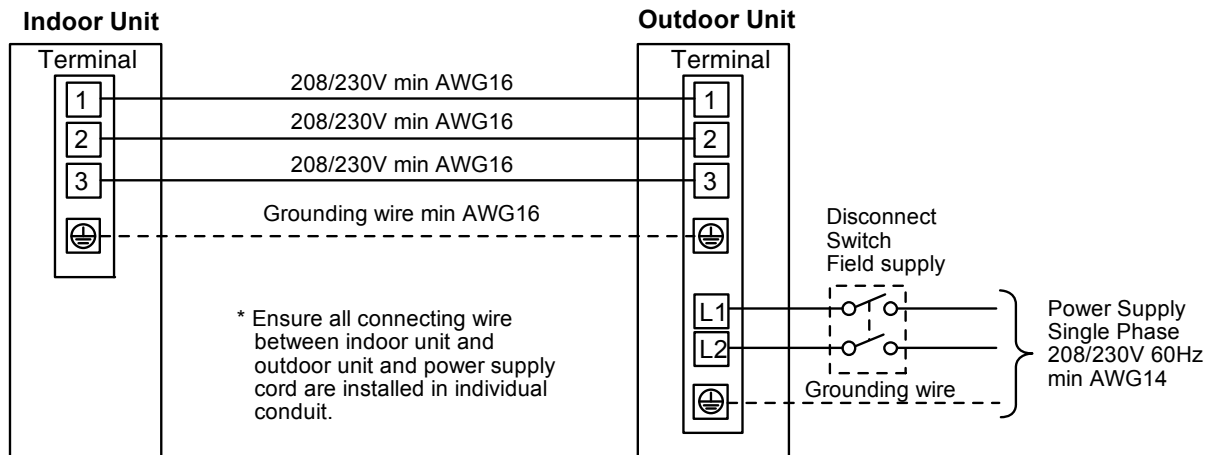
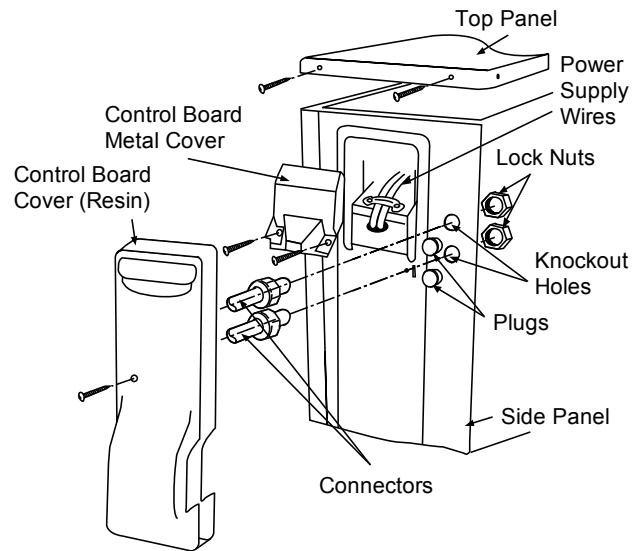

9. Secure the wire onto the control board with the holder (clammer).
10. After completing wiring connections, reattach the control board cover (Metal and Resin) and the top panel to the original position with the screws.
11. For wire stripping and connection requirement, refer to instruction 11.2.5 of indoor unit.

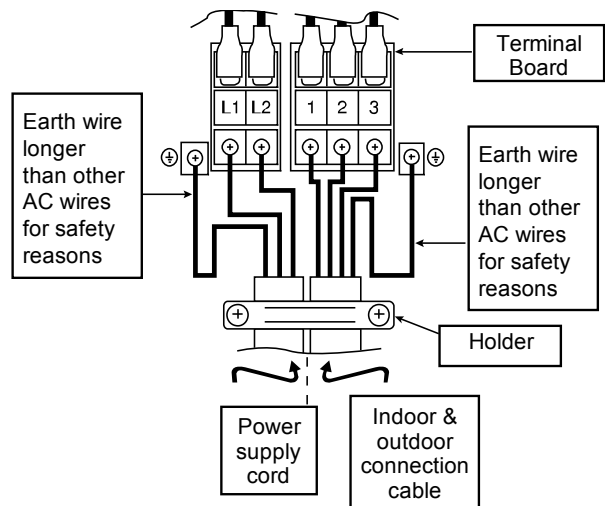

WARNING
 This equipment must be properly earthed.

- Earth lead wire shall be Yellow/Green (Y/G) in colour and shall be longer than other lead wires as shown in the figure for electrical safety in case of slipping.

11.3.3.2 Piping Insulation

1. Please carry out insulation at pipe connection portion as mentioned in Indoor/Outdoor Unit Installation Diagram. Please wrap the insulated piping end to prevent water from going inside the piping.
2. If drain hose or connecting piping is in the room (where dew may form), please increase the insulation by using POLY-E FOAM with thickness 1/4" (6 mm) or above.

12. Installation Instruction (RE18SKUA and RE24SKUA)

12.1 Select the Best Location

12.1.1 Indoor Unit

- Do not install the unit in excessive oil fume area such as kitchen, workshop etc.
- There should not be any heat source or steam near the unit.
- There should not be any obstacles blocking the air circulation.
- A place where air circulation in the room is good.
- A place where drainage can be easily done.
- A place where noise prevention is taken into consideration.
- Do not install the unit near the doorway.
- Ensure the spaces indicated by arrows from the wall, ceiling, fence or other obstacles.
- Recommended installation height for indoor unit shall be at least 8 ft (2.4 m).

12.1.2 Outdoor Unit

- If an awning is built over the unit to prevent direct sunlight or rain, be careful that heat radiation from the condenser is not obstructed.
- There should not be any animal or plant which could be affected by hot air discharged.
- Keep the spaces indicated by arrows from wall, ceiling, fence or other obstacles.
- Do not place any obstacles which may cause a short circuit of the discharged air.
- If piping length is over the [piping length for additional gas], additional refrigerant should be added as shown in the table.
- Recommended installation height for outdoor unit should be above the seasonal snow level.
- Be careful not to locate outdoor unit directly under a roof line where falling snow or ice can cause damage or dripping water can increase ice accumulation and defrost cycles.

12.1.3 Indoor/Outdoor Unit Installation Diagram

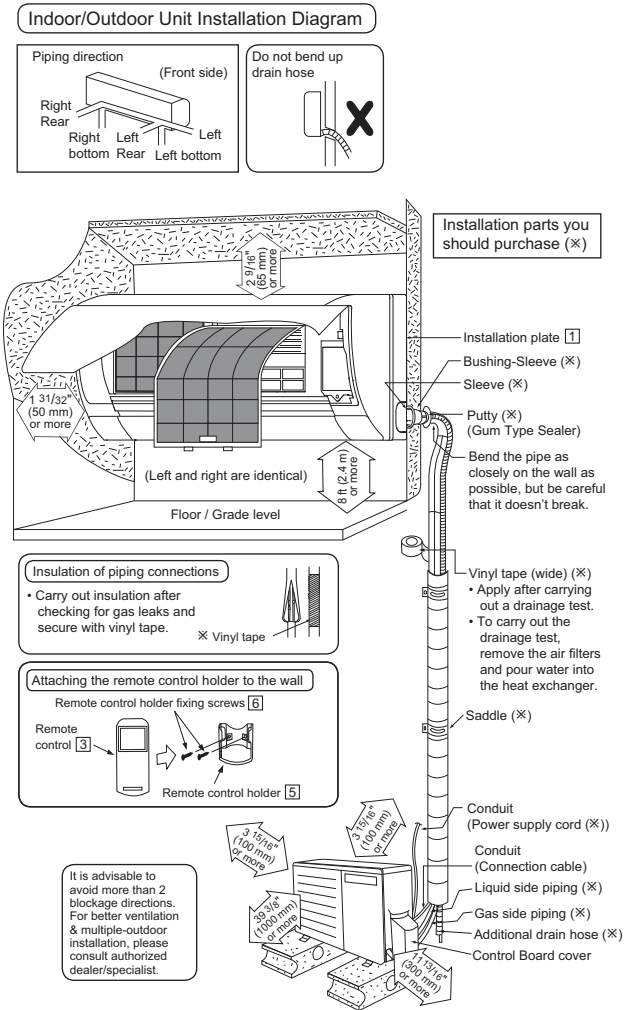

- This illustration is for explanation purposes only. The indoor unit will actually face a different way.

Model	Capacity (Btu/h)	Piping size		Std. Length	Max. Elevation	Min. Piping Length	Max. Piping Length	Additional Refrigerant	Piping Length for add. gas
		Gas	Liquid						
RE18SKUA	17200	1/2" (12.7 mm)	1/4"	24.6 ft (7.5 m)	49.2 ft (15 m)	9.8 ft (3 m)	65.6 ft (20 m)	0.2 oz/ft (20 g/m)	24.6 ft (7.5 m)
RE24SKUA	22000	5/8" (15.88 mm)	(6.35 mm)						

Example: For RE18SKUA

If the unit is installed at 41 ft (12.5 m) distance, the quantity of additional refrigerant should be 3.28 oz (100 g) (41 – 24.6) ft x 0.2 oz/ft = 3.28 oz. (12.5 – 7.5) m x 20 g/m = 100 g).

12.2 Indoor Unit

12.2.1 How to Fix Installation Plate

The mounting wall shall be strong and solid enough to prevent it from the vibration.

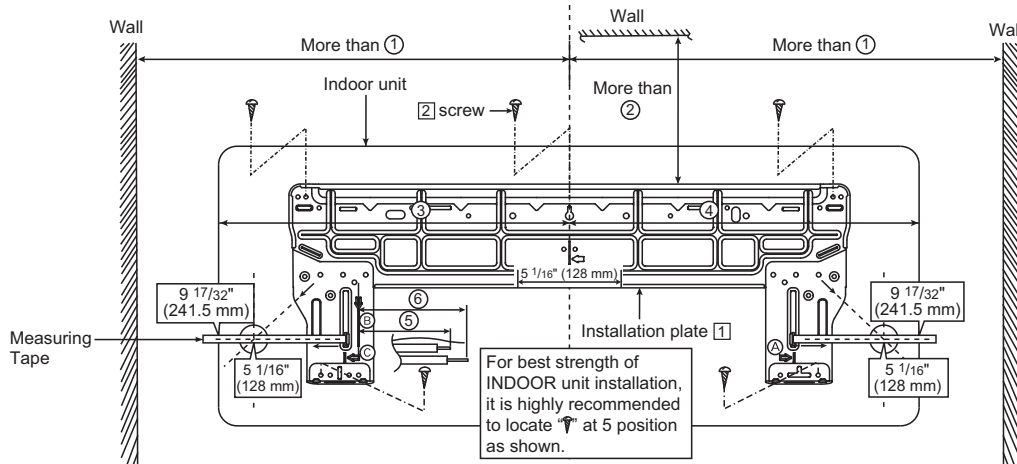

Model	Dimension					
	①	②	③	④	⑤	⑥
RE18SKUA, RE24SKUA	23 7/32" 590 mm	3 7/32" 82 mm	21 7/32" 539 mm	20 15/16" 532 mm	6 21/32" 169 mm	8 5/8" 219 mm

The center of installation plate should be at more than ① at right and left of the wall.

The distance from installation plate edge to ceiling should more than ②.

From installation plate left edge to unit's left side is ③.

From installation plate right edge to unit's right is ④.

Ⓑ : For left side piping, piping connection for liquid should be about ⑤ from this line.

: For left side piping, piping connection for gas should be about ⑥ from this line.

1 Mount the installation plate on the wall with 5 screws or more (at least 5 screws).

(If mounting the unit on the concrete wall, consider using anchor bolts.)

○ Always mount the installation plate horizontally by aligning the marking-off line with the thread and using a level gauge.

2 Drill the piping plate hole with $\varnothing 2 \frac{3}{4}$ " ($\varnothing 70$ mm) hole-core drill.

○ Line according to the left and right side of the installation plate. The meeting point of the extended line is the center of the hole. Another method is by putting measuring tape at position as shown in the diagram above. The hole center is obtained by measuring the distance namely $5 \frac{1}{16}$ " (128 mm) for left and right hole respectively.

○ Drill the piping hole at either the right or the left and the hole should be slightly slanting to the outdoor side.

12.2.2 To Drill a Hole in the Wall and Install a Sleeve of Piping

1 Insert the piping sleeve to the hole.

2 Fix the bushing to the sleeve.

3 Cut the sleeve until it extrudes about $1 \frac{9}{32}$ " (15 mm) from the wall.

⚠ CAUTION

❗ When the wall is hollow, please be sure to use the sleeve for tube assembly to prevent dangers caused by mice biting the connection cable.

4 Finish by sealing the sleeve with putty or caulking compound at the final stage.

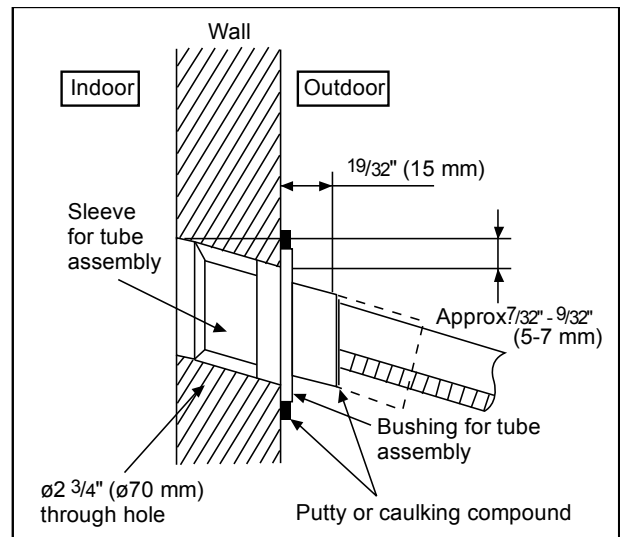

12.2.3 Indoor Unit Installation

- Do not turn over the unit without its shock absorber during pull out the piping. It may cause intake grille damage.
- Use shock absorber during pull out the piping to protect the intake grille from damage.

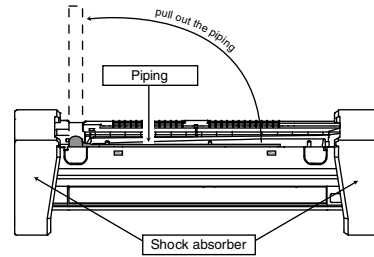
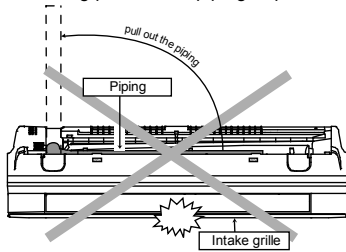

12.2.3.1 For the right rear piping

- Step-1** Pull out the Indoor piping
- Step-2** Install the Indoor Unit
- Step-3** Secure the Indoor Unit
- Step-4** Insert the connection cable

12.2.3.2 For the right bottom piping

- Step-1** Pull out the Indoor piping
- Step-2** Install the Indoor Unit
- Step-3** Insert the connection cable
- Step-4** Secure the Indoor Unit

12.2.3.3 For the embedded piping

- Step-1** Replace the drain hose
- Step-2** Bend the embedded piping
 - Use a spring bender or equivalent to bend the piping so that the piping is not crushed.
- Step-3** Pull the connection cable into Indoor Unit
 - The inside and outside connection cable can be connected without removing the front grille.
- Step-4** Cut and flare the embedded piping
 - When determining the dimensions of the piping, slide the unit all the way to the left on the installation plate.
 - Refer to the section "Cutting and flaring the piping".
- Step-5** Install the Indoor Unit
- Step-6** Connect the piping
 - Please refer to "Connecting the piping" column in outdoor unit section. (Below steps are done after connecting the outdoor piping and gas-leakage confirmation.)
- Step-7** Insulate and finish the piping
 - Please refer to "Piping and finishing" column of outdoor section and "Insulation of piping connection" column as mentioned in indoor/outdoor unit installation.
- Step-8** Secure the Indoor Unit

Right Rear piping

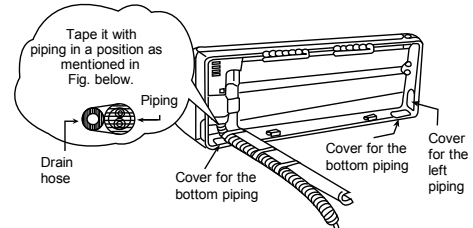

How to keep the cover

In case of the cover is cut, keep the cover at the rear of chassis as shown in the illustration for future reinstallation. (Left, right and 2 bottom covers for piping.)

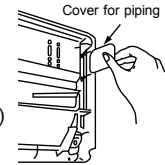

Right and Right Bottom piping

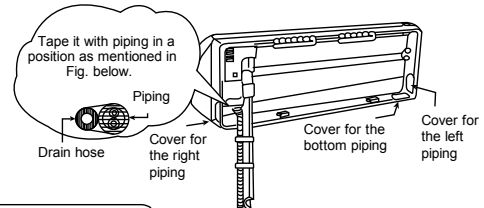

Install the indoor unit

Hook the indoor unit onto the upper portion of installation plate. (Engage the indoor unit with the upper edge of the installation plate). Ensure the hooks are properly seated on the installation plate by moving it in left and right.

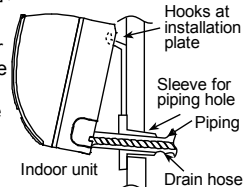

Secure the Indoor Unit

Press the lower left and right side of the unit against the installation plate until hooks engages with their slot (sound click).

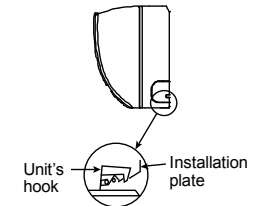

Insert the connection cable

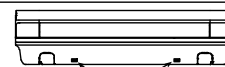
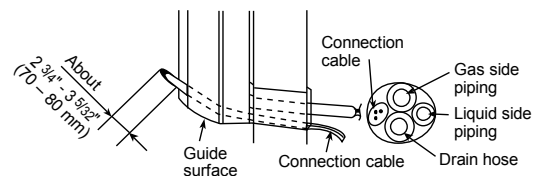

To take out the unit, push the [PUSH] marking at the bottom unit, and pull it slightly towards you to disengage the hooks from the unit.

(This can be used for left rear piping and bottom piping also.)

Replace the drain hose

Rear view for left piping installation

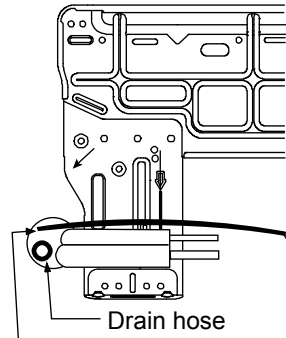
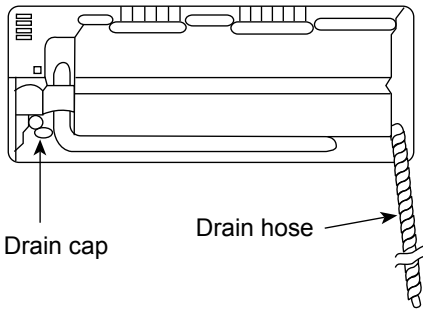

Adjust the piping slightly downwards.

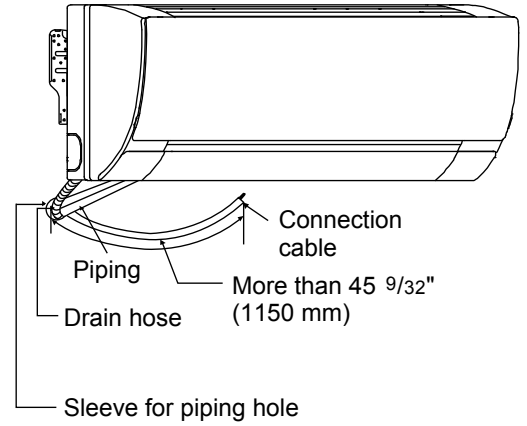

- How to pull the piping and drain hose out, in case of the embedded piping

Apply putty or caulking material to seal the wall opening.

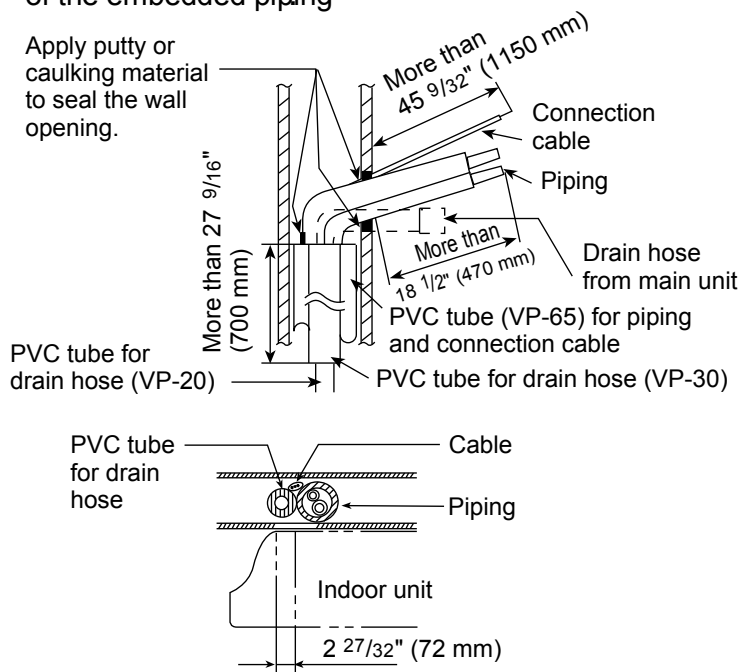

- In case of left piping how to insert the connection cable and drain hole.

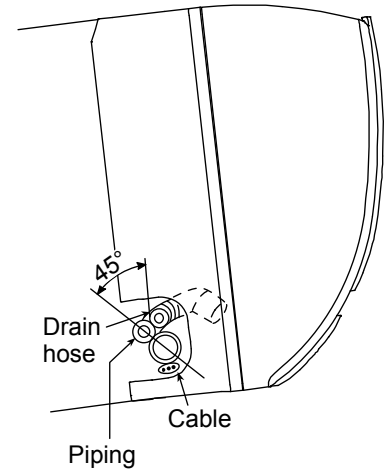

(For the right piping, follow the same procedure)

Drain hose adapter 8 usage

- Join indoor drain hose to $\frac{3}{4}$ " (20 mm) nominal PVC pipe size by using drain hose adapter 8 when necessary.

Remarks :

Make sure indoor unit drain hose & $\frac{3}{4}$ " (20 mm) nominal PVC pipe are fully inserted to drain hose adapter 8.

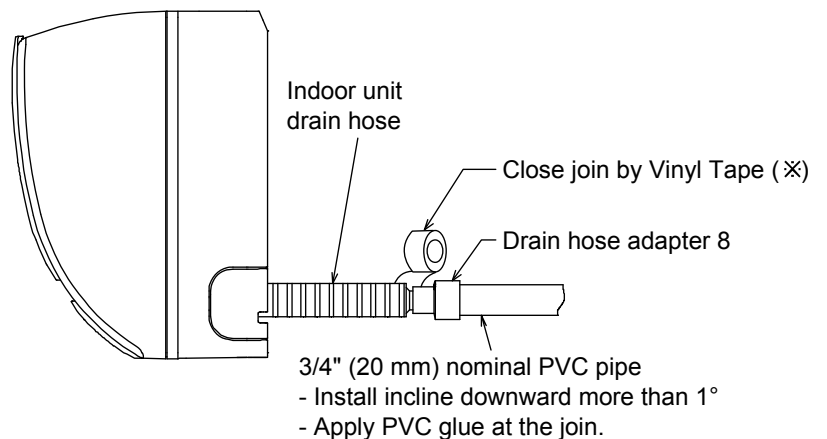

12.2.4 Connect the Cable to the Indoor Unit

1. The inside and outside connection cable can be connected without removing the front grille.
2. Unscrew the conduit cover and fix the conduit connector to conduit cover with lock nut, then secure it against chassis.
3. Connecting wire between indoor unit and outdoor unit should be UL listed or CSA approved 4 conductor wires minimum AWG16 in accordance with local electric codes.
 - o Ensure the colour of wires of outdoor unit and terminal number are the same as the indoor's respectively.

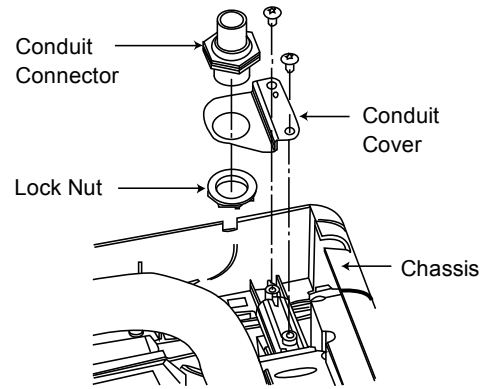

Rear Side of Indoor Unit

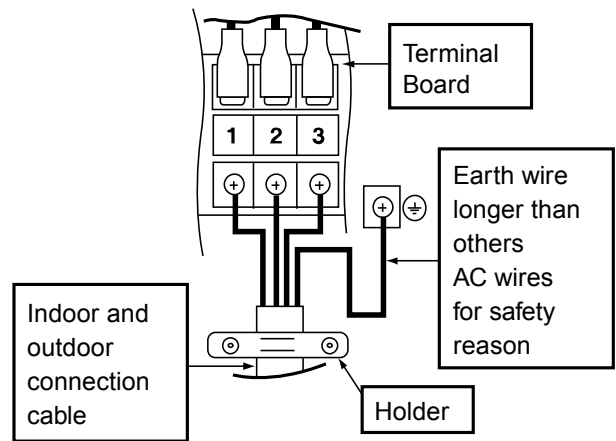

Terminals on the indoor unit	1	2	3	
Colour of wires (Connecting wire)				
Terminals on the outdoor unit	1	2	3	

WARNING

This equipment must be properly earthed.

- o Earth lead wire shall be Yellow/Green (Y/G) in colour and shall be longer than other lead wires as shown in the figure for electrical safety in case of the slipping.

12.2.4.1 Wire Stripping, Connecting Requirement

Wire stripping

13/32" ± 1/16"

10 ± 1 mm

No loose strand when inserted

Indoor/outdoor connection terminal board

7/32" (5 mm) or more (gap between wires)

Conductor fully inserted	Conductor over inserted	Conductor not fully inserted
ACCEPT	PROHIBITED	PROHIBITED

WARNING

RISK OF FIRE

JOINING OF WIRES MAY CAUSE OVERHEATING AND FIRE.

Do not joint wires

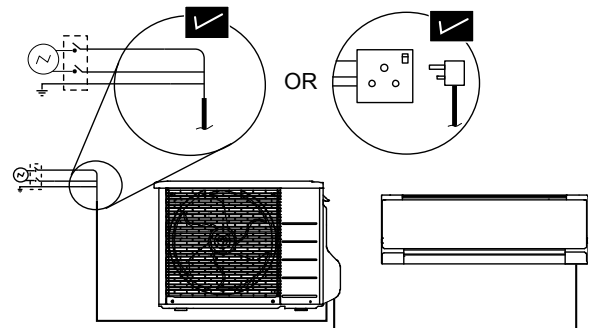
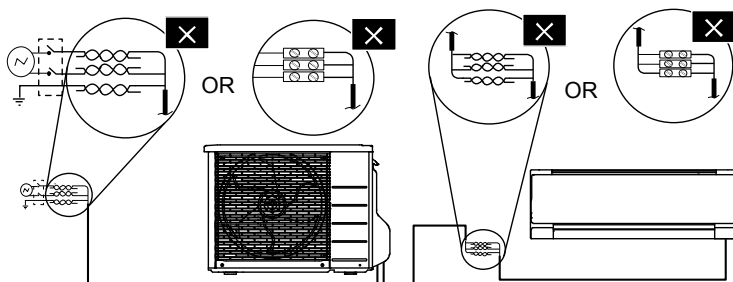

- ! Use complete wire without joining.
- ! Use approved socket and plug with earth pin.
- ! Wire connection in this area must follow to national wiring rules.

12.2.4.2 Cutting and flaring the piping

- 1 Please cut using pipe cutter and then remove the burrs.
- 2 Remove the burrs by using reamer. If burrs are not removed, gas leakage may be caused. Turn the piping end down to avoid the metal powder entering the pipe.
- 3 Please make flare after inserting the flare nut onto the copper pipes.

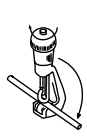

1. To cut

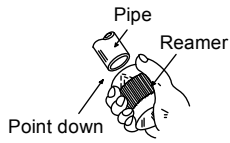

2. To remove burrs

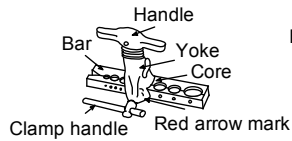

3. To flare

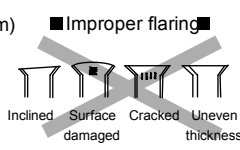
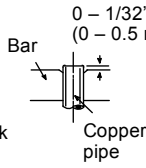

When properly flared, the internal surface of the flare will evenly shine and be of even thickness. Since the flare part comes into contact with the connections, carefully check the flare finish.

12.3 Outdoor Unit

12.3.1 Install the Outdoor Unit

- After selecting the best location, start installation to Indoor/Outdoor Unit Installation Diagram.
 - Fix the unit on concrete or rigid frame firmly and horizontally by bolt nut $\phi 13/32"$ ($\phi 10$ mm).
 - When installing at roof, please consider strong wind and earthquake.
Please fasten the installation stand firmly with bolt or nails.

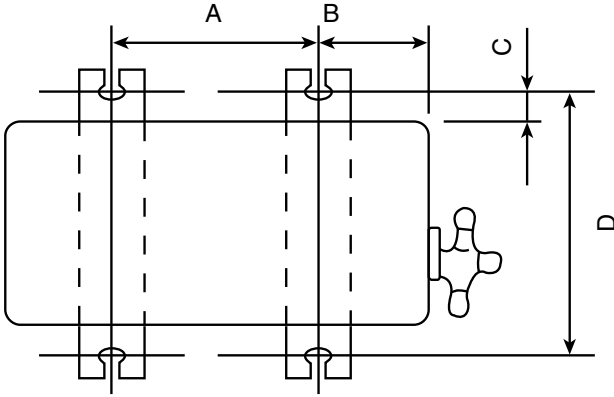

Model	A	B	C	D
RE18SKUA, RE24SKUA	24-1/8" (613 mm)	5-5/32" (131 mm)	5/8" (16 mm)	14-3/16" (360.5 mm)

12.3.2 Connect the Piping

12.3.2.1 Connecting the piping to indoor

Please make flare after inserting flare nut (locate at joint portion, of tube assembly) onto the copper pipe. (In case of using long piping)

Connect the piping

- Align the center of piping and sufficiently tighten the flare nut with fingers.
- Further tighten the flare nut with torque wrench in specified torque as stated in the table.

12.3.2.2 Connecting the piping to outdoor

Decide piping length and then cut by using pipe cutter. Remove burrs from cut edge.

Make flare after inserting the flare nut (locate at valve) onto the copper pipe.

Align center of piping to valves and then tighten with torque wrench to the specified torque as stated in the table

12.3.2.3 Gas Leak Checking

Pressure test to system to 400 PSIG with dry nitrogen, in stages. Thoroughly leak check the system. If the pressure holds, release the nitrogen and proceed to section 12.3.3.

Do not over tighten, over tightening may cause gas leakage.

Piping size	Torque
1/4" (6.35 mm)	13.3 lbf.ft [18 N•m (1.8 kgf•m)]
3/8" (9.52 mm)	31.0 lbf.ft [42 N•m (4.3 kgf•m)]
1/2" (12.7 mm)	40.6 lbf.ft [55 N•m (5.6 kgf•m)]
5/8" (15.88 mm)	47.9 lbf.ft [65 N•m (6.6 kgf•m)]
3/4" (19.05 mm)	73.8 lbf.ft [100 N•m (10.2 kgf•m)]

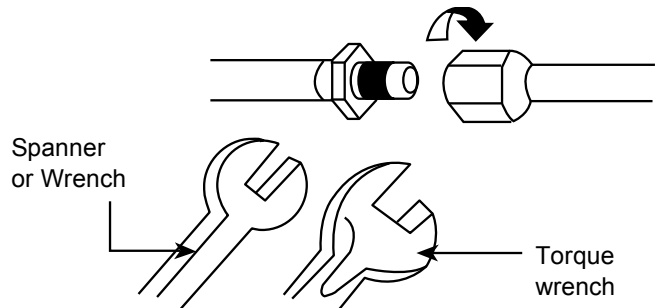

12.3.3 Evacuation of the Equipment

WHEN INSTALLING AN AIR CONDITIONER, BE SURE TO EVACUATE THE AIR INSIDE THE INDOOR UNIT AND PIPES in the following procedure.

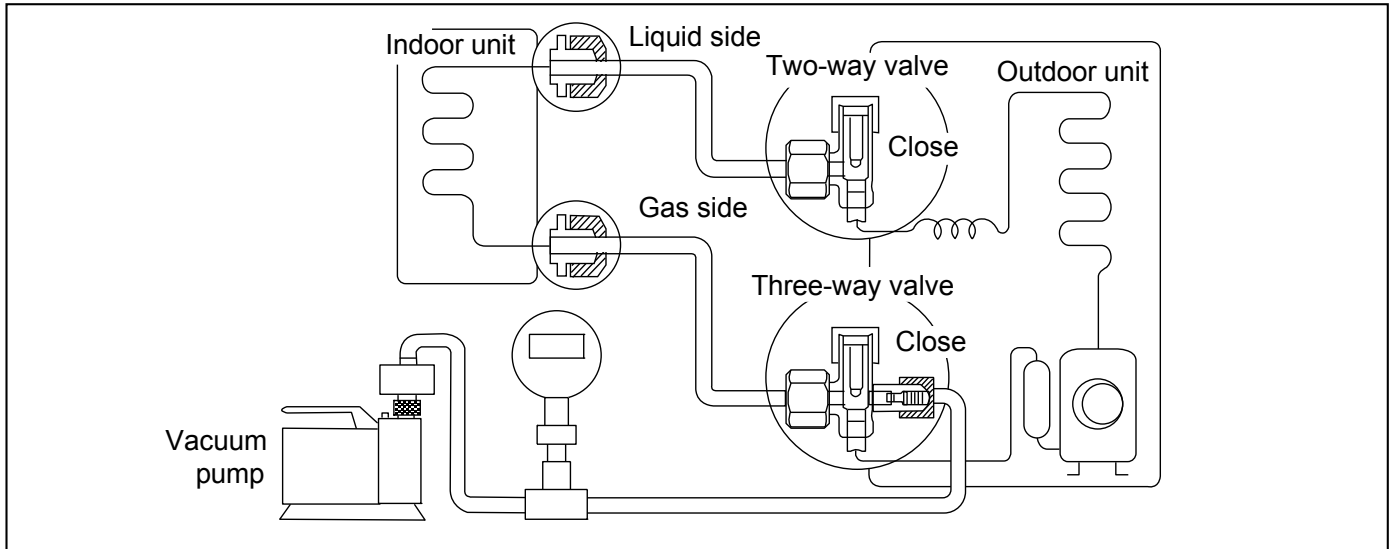

1. Connect a charging hose with a push pin to the Low side of a charging set and the service port of the 3-way valve.
2. Connect the micron gauge between vacuum pump and service port of outdoor units.
3. Turn on the power switch of the vacuum pump and make sure that connect digital micron gauge and to pull down to a value of 500 microns.
4. To make sure micron gauge a value 500 microns and close the low side valve of the charging set and turn off the vacuum pump.
5. Disconnect the vacuum pump house from the service port of the 3-way valve.
6. Tighten the service port caps of the 3-way valve at a torque of 13.3 lbf·ft (18 N·m) with a torque wrench.
7. Remove the valve caps of both of the 2-way valve and 3-way valve. Position both of the valves to "Open" using a hexagonal wrench (5/32" (4 mm)).
8. Mount valve caps onto the 2-way valve and the 3-way valve.
 - Be sure to check for gas leakage.

- If micron gauge value does not descend 500 microns, take the following measures:
 - If the leak stops when the piping connections are tightened further, continue working from step ③.
 - If the leak does not stop when the connections are retightened, repair location of leak.
 - Do not release refrigerant during piping work for installation and reinstallation.
 - Be careful with the liquid refrigerant, it may cause frostbite.

12.3.3.1 Connect the Cable to the Outdoor Unit

1. Remove control board cover (Resin and Metal).
2. Remove particular plate.
3. Remove plugs.
4. Fix the conduit connectors to the knockout holes with lock-nuts, then secure them against the side panel.
5. All wires pass through conduits & particular plate's opening hole.
6. Connecting wire between indoor unit and outdoor unit should be UL listed or CSA approved 4 conductor wires minimum AWG16 in accordance with local electric codes.
7. Wire connection to the power supply (208/230V 60Hz) through circuit breaker.
 - o Connect the UL listed or CSA approved wires minimum AWG12 to the terminal board, and connect the other end of the wires to ELCB / GFCI.
8. Connect the power supply cord and connecting wire between indoor unit and outdoor unit according to the diagram below.

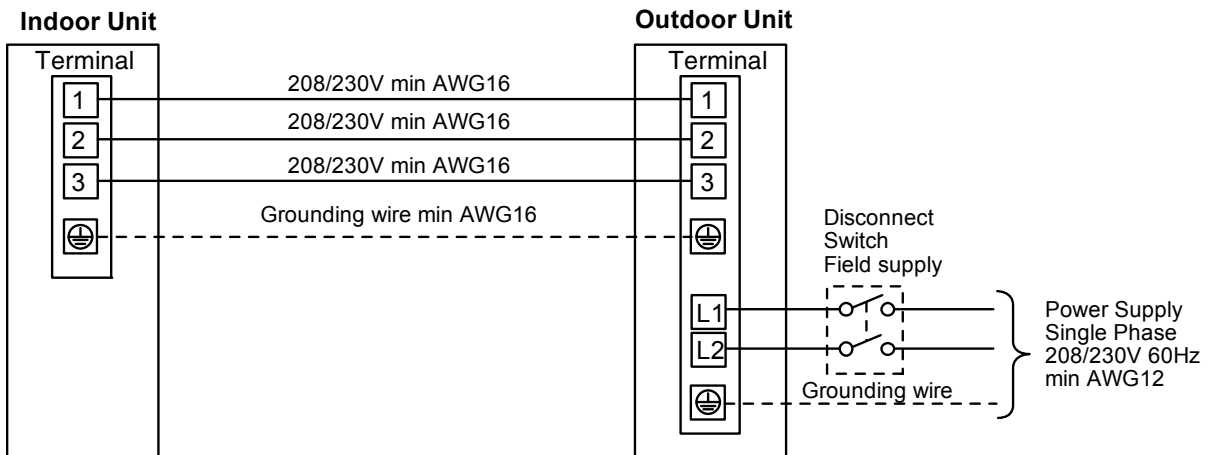
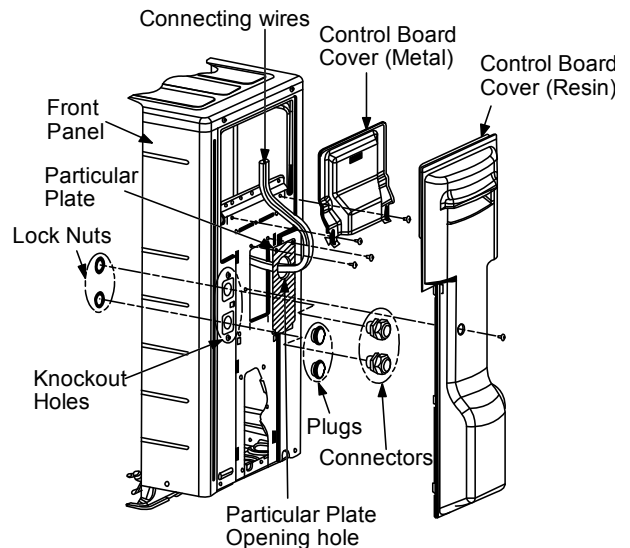

9. Secure the wire onto the control board with the holder (clammer).
10. After completing wiring connections, reattach the particular plate and control board cover (Metal and Resin) to the original position with the screws.
11. For wire stripping and connection requirement, refer to instruction 12.2.5 of indoor unit.

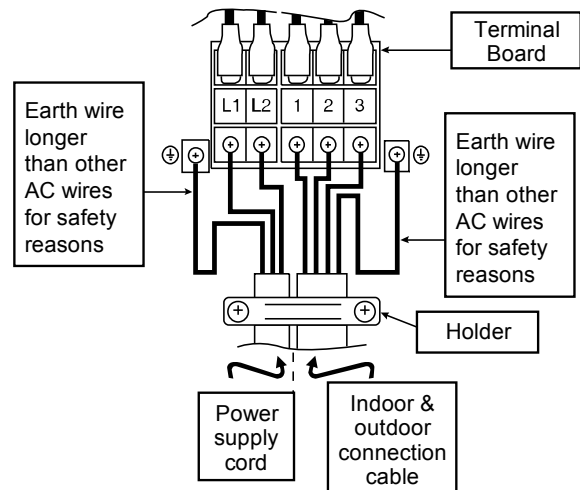

⚠ WARNING

⊕ This equipment must be properly earthed.

- Earth lead wire shall be Yellow/Green (Y/G) in colour and should be longer than other lead wires as shown in the figure for electrical safety in case of slipping.

12.3.3.2 Piping Insulation

1. Please carry out insulation at pipe connection portion as mentioned in Indoor/Outdoor Unit Installation Diagram. Please wrap the insulated piping end to prevent water from going inside the piping.
2. If drain hose or connecting piping is in the room (where dew may form), please increase the insulation by using POLY-E FOAM with thickness 1/4" (6 mm) or above.

13. Operation Control

13.1 Basic Function

Inverter control, which equipped with a microcomputer in determining the most suitable operation mode as time passes, automatically adjusts output power for maximum comfort always. In order to achieve the suitable operation mode, the microcomputer maintains the set temperature by measuring the temperature of the environment and performing temperature shifting. The compressor at outdoor unit is operating following the frequency instructed by the microcomputer at indoor unit that judging the condition according to internal setting temperature and intake air temperature.

13.1.1 Internal Setting Temperature

Once the operation starts, remote control setting temperature will be taken as base value for temperature shifting processes. These shifting processes are depending on the air conditioner settings and the operation environment. The final shifted value will be used as internal setting temperature and it is updated continuously whenever the electrical power is supplied to the unit.

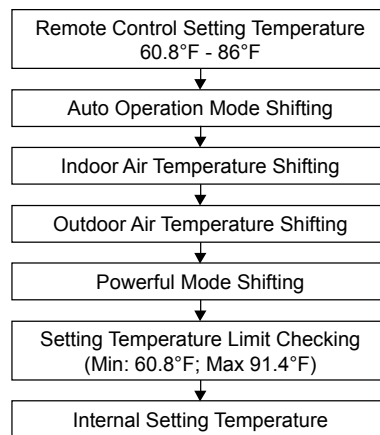

13.1.2 Cooling Operation

13.1.2.1 Thermostat control

- Compressor is OFF when intake Air Temperature - Internal Setting Temperature < 2.7°F.
- Compressor is ON after waiting for 3 minutes, if the Intake Temperature - Internal Setting Temperature > Compressor OFF point.

13.1.3 Soft Dry Operation

13.1.3.1 Thermostat control

- Compressor is OFF when Intake Temperature - Internal Setting Temperature < -3.6°F.
- Compressor is ON after waiting for 3 minutes, if the Intake Air Temperature - Internal Setting Temperature > Compressor OFF point.

13.1.4 Heating Operation

13.1.4.1 Thermostat control

- Compressor is OFF when Intake Temperature - Internal Setting Temperature > 3.6°F.
- Compressor is ON after waiting for 3 minutes, if the Intake Air Temperature - Internal Setting Temperature < Compressor OFF point

13.1.4.2 Automatic Operation

- This mode can be set using remote control and the operation is decided by remote control setting temperature, remote control operation mode and indoor intake air temperature.
- During operation mode judgment, indoor fan motor (with speed of Lo-) is running for 30 seconds to detect the indoor intake air temperature.
- Every 10 minutes, the indoor temperature is judged.
- For the 1st judgment
 - If indoor intake temperature - remote control setting temperature $\geq 3.6^{\circ}\text{F}$, COOL mode is decided.
 - If $-3.6^{\circ}\text{F} \leq$ indoor intake temperature - remote control setting temperature $< 3.6^{\circ}\text{F}$, DRY mode is decided.
 - If indoor intake temperature - remote control setting temperature $< -3.6^{\circ}\text{F}$, HEAT mode is decided.

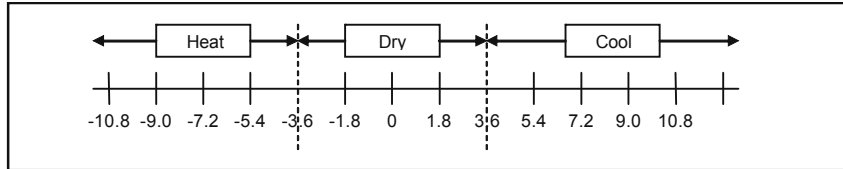

- For the 2nd judgment onwards
 - If indoor intake temperature - remote control setting temperature $\geq 5.4^{\circ}\text{F}$, if previous operate in DRY mode, then continue in DRY mode. otherwise COOL mode is decided.
 - If $-3.6^{\circ}\text{F} \leq$ indoor intake temperature - remote control setting temperature $< 5.4^{\circ}\text{F}$, maintain with previous mode.
 - If indoor intake temperature - remote control setting temperature $< -3.6^{\circ}\text{F}$, HEAT mode is decided.

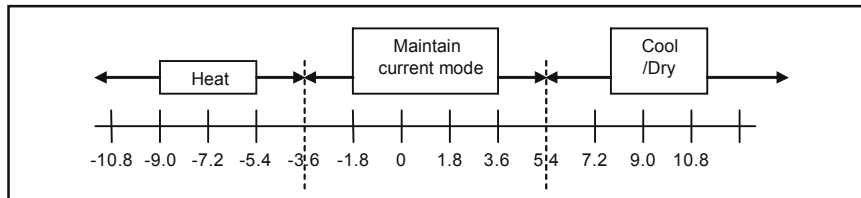

13.2 Indoor Fan Speed Control

- Indoor Fan Speed can be set using remote control.

13.2.1 Fan Speed Rotation Chart

			RE9SKUA	RE12SKUA	RE18SKUA	RE24SKUA
Mode	Fan Tap	Application	rpm	rpm	rpm	rpm
COOL	SHi	Pwr Me+	1250	1350	1480	1500
	Hi	Fc, RC	1120	1230	1380	1400
	Me+	RC	1010	1110	1300	1320
	Me	RC	910	1000	1220	1240
	Me-	RC	810	890	1140	1160
	Lo	Fcmin, RC	710	780	1060	1090
	Lo-	QuietLo	610	620	970	1000
	SLo	Dry	550	560	690	690
	SSLo	Auto Cut	540	550	580	580

			RE9SKUA	RE12SKUA	RE18SKUA	RE24SKUA
Mode	Fan Tap	Application	rpm	rpm	rpm	rpm
HEAT	SSH	Pwr Me+	1300	1430	1500	1600
	SHi	Fh, RC	1250	1380	1410	1500
	Me+	RC	1140	1290	1330	1430
	Me	RC	1040	1210	1260	1360
	Me-	RC	930	1120	1190	1290
	Lo	Fhmin, RC	830	1040	1120	1220
	Lo-	QuietLo	730	940	1030	1110
	SLo	Thermo Off, Hot start	570	570	430	430
	SSLo	Thermo Off	560	560	330	330

13.3 Indoor Fan Motor Operation

13.3.1 Basic Rotation Speed (rpm)

- Manual Fan Speed
[Cooling, Dry]
 - Fan motor's number of rotation is determined according to remote control setting.

Remote control	○	○	○	○	○
Tab	Hi	Me+	Me	Me-	Lo

[Heating]

- Fan motor's number of rotation is determined according to remote control setting.

Remote control	○	○	○	○	○
Tab	Shi	Me+	Me	Me-	Lo

- Auto Fan Speed
[Cooling, Dry]
 - According to room temperature and setting temperature, indoor fan speed is determined automatically.
 - The indoor fan will operate according to pattern below.

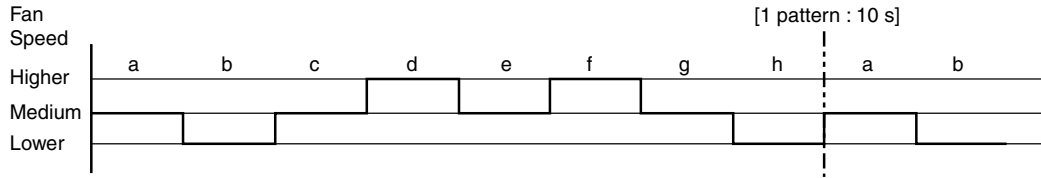

- During operation, indoor fan motor may stop due to odor prevention.

[Heating]

- According to indoor pipe temperature, automatic heating fan speed is determined as follows.

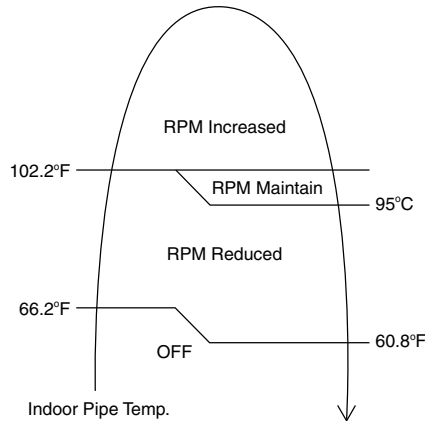

- Feedback control
 - Immediately after the fan motor started, feedback control is performed once every second.
 - During fan motor on, if fan motor feedback ≥ 2550 rpm or < 50 rpm continue for 10 seconds, then fan motor error counter increase, fan motor is then stop and restart. If the fan motor counter becomes 7 times, then H19 - fan motor error is detected. Operation stops and cannot on back.

13.4 Outdoor Fan Motor Operation

Outdoor fan motor is operated with fan speed number of rotation. It starts when compressor starts operation and it stops 30 seconds after compressor stops operation.

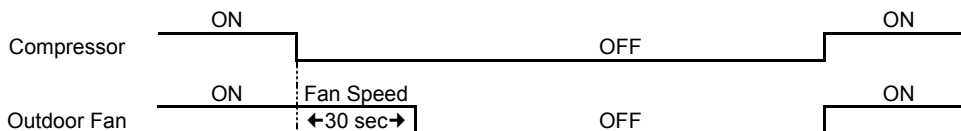

13.5 Airflow Direction

- There are two types of airflow, vertical airflow (directed by horizontal vane) and horizontal airflow (directed by vertical vanes).
- Control of airflow direction can be automatic (angles of direction is determined by operation mode, heat exchanger temperature and intake air temperature) and manual (angles of direction can be adjusted using remote control).

13.5.1 Vertical Airflow

13.5.1.1 CU-RE9SKUA CU-RE12SKUA

Operation Mode	Airflow Direction		Vane angle (°)				
			1	2	3	4	5
Heating	Auto with Heat Exchanger Temperature	A	20				
		B	57				
		C	32				
	Manual		20	32	45	57	68
Cooling	Auto		20 ~ 45				
	Manual		20	26	32	37	45
Soft Dry	Auto		20 ~ 45				
	Manual		20	26	32	37	45

13.5.1.2 CU-RE18SKUA CU-RE24SKUA

Operation Mode	Airflow Direction		Vane angle (°)				
			1	2	3	4	5
Heating	Auto with Heat Exchanger Temperature	A	20				
		B	45				
		C	32				
	Manual		20	32	45	57	68
Cooling	Auto		20 ~ 45				
	Manual		20	26	32	37	45
Soft Dry	Auto (Anti-Dew Control)		20 ~ 45				
	Manual (Anti-Dew Control)		20	26	32	37	45

- Automatic vertical airflow direction can be set using remote control; the vane swings up and down within the angles as stated above. For heating mode operation, the angle of the vane depends on the indoor heat exchanger temperature as Figure 1 below. When the air conditioner is stopped using remote control, the vane will shift to close position.
- Manual vertical airflow direction can be set using remote control; the angles of the vane are as stated above and the positions of the vane are as Figure 2 below. When the air conditioner is stopped using remote control, the vane will shift to close position.

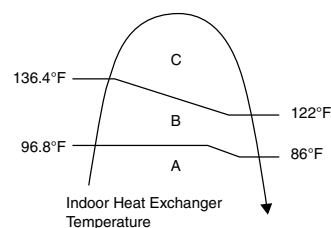

Figure 1

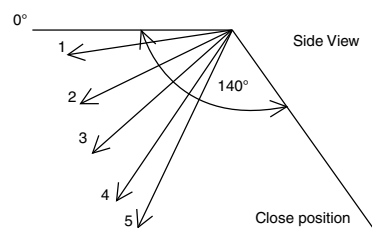

Figure 2

13.5.2 Horizontal Airflow (CU-RE9SKUA CU-RE12SKUA)

The horizontal airflow direction louvers can be adjusted manually by hand.

13.5.3 Horizontal Airflow (CU-RE18SKUA CU-RE24SKUA)

- Automatic horizontal airflow direction can be set using remote control; the vane swings left and right within the angles as stated below. For heating mode operation, the angle of the vane depends on the indoor heat exchanger temperature as Figure 1 below.

Operation Mode		Vane Angle (°)
Heating with heat exchanger temperature	A	68 ~ 112
	B	90
Cooling and Soft Stry		68 ~ 112

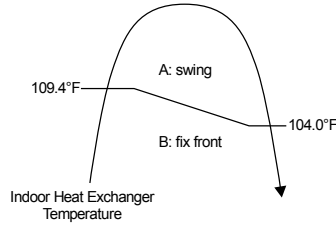

Figure 1

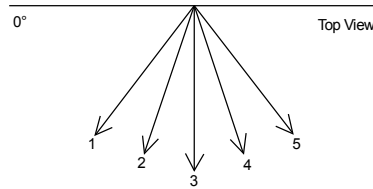

Figure 2

- Manual vertical airflow direction can be set using remote control; the angles of the vane are as stated below and the positions of the vane are as figure below:

Pattern	1	2	3	4	5
Airflow Direction Patterns at Remote Control					
Vane Angle (°)	90	68	78	102	112

13.6 Quiet Operation (Cooling Mode/Cooling Area of Dry Mode)

- Purpose
 - To provide quiet cooling operation compare to normal operation.
- Control condition
 - Quiet operation start condition
 - When "Quiet" button at remote control is pressed. Quiet LED illuminates.
 - Quiet operation stop condition
 - When one of the following conditions is satisfied, quiet operation stops:
 - POWERFUL/QUIET button is pressed.
 - Stop by OFF/ON button.
 - OFF Timer activates.
 - POWERFUL/QUIET button is pressed again.
 - When quiet operation is stopped, operation is shifted to normal operation with previous setting.
 - When fan speed is changed, quiet operation is shifted to quiet operation of the new fan speed.
 - When operation mode is changed, quiet operation is shifted to quiet operation of the new mode.
 - During quiet operation, if ON timer activates, quiet operation maintains.
 - After off, when on back, quiet operation is not memorised.
- Control contents
 - Auto fan speed is change from normal setting to quiet setting of respective fan speed. This is to reduce sound of Hi, Me, Lo for 3dB.
 - Manual fan speed for quiet operation is -1 step from setting fan speed.

13.7 Quiet Operation (Heating)

- Purpose
 - To provide quiet heating operation compare to normal operation.
- Control condition
 - Quiet operation start condition
 - When “POWERFUL/QUIET” button at remote control is pressed.
Quiet LED illuminates.
 - Quiet operation stop condition
 - When one of the following conditions is satisfied, quiet operation stops:
 - Stop by OFF/ON button.
 - Timer “off” activates.
 - POWERFUL/QUIET button is pressed again.
 - When quiet operation is stopped, operation is shifted to normal operation with previous setting.
 - When fan speed is changed, quiet operation is shifted to quiet operation of the new fan speed.
 - When operation mode is changed, quiet operation is shifted to quiet operation of the new mode.
 - During quiet operation, if timer “on” activates, quiet operation maintains.
 - After off, when on back, quiet operation is not memorised.
- Control contents
 - Fan speed auto
 - Indoor FM RPM depends on pipe temperature sensor of indoor heat exchanger. Auto fan speed is changed from normal setting to quiet setting of respective fan speed. This is to reduce sound of Hi, Me, Lo for 3dB.
 - Fan speed manual
 - Manual fan speed for quiet operation is -1 step from setting fan speed.

13.8 Powerful Mode Operation

- When the powerful mode is selected, the internal setting temperature will shift lower up to 3.6°F (for Cooling/Soft Dry) or higher up to 6.3°F (for Heating) than remote control setting temperature for 20 minutes to achieve the setting temperature quickly.

13.9 Timer Control

13.9.1 ON Timer Control

- ON Timer can be set using remote control, where the unit with timer set will start operation earlier than the setting time. This is to provide a comfortable environment when reaching the set ON time.
- 60 minutes before the set ON time, indoor (at fan speed of Lo-) and outdoor fan motor start operation for 30 seconds to determine the indoor intake air temperature and outdoor air temperature in order to judge the operation starting time.
- From the above judgment, the decided operation will start operation earlier than the set time as shown below.

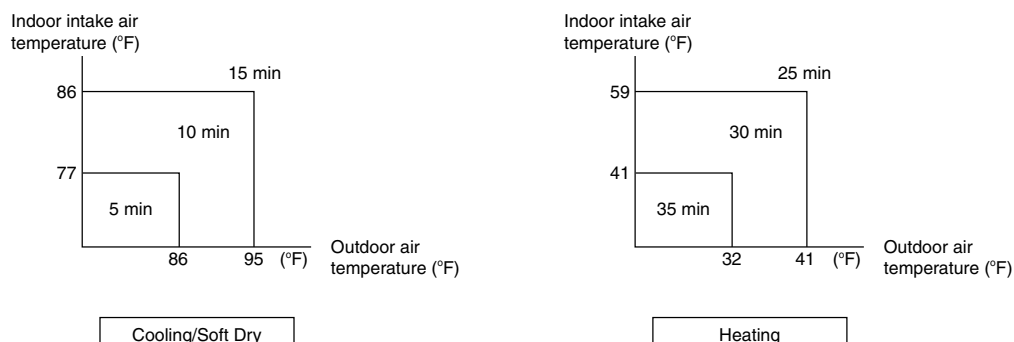

13.9.2 OFF Timer Control

- OFF Timer can be set using remote control, the unit with timer set will stop at set time.

13.10 Auto Restart Control

- When the power supply is cut off during the operation of air conditioner, the compressor will re-operate within three to four minutes (there are 10 patterns between 2 minutes 58 seconds and 3 minutes 52 seconds to be selected randomly) after power supply resumes.
- This type of control is not applicable during ON/OFF Timer setting.

13.11 Indication Panel

LED	POWER	TIMER	QUIET	POWERFUL
Color	Green	Orange	Orange	Orange
Light ON	Operation ON	Timer Setting ON	Quiet Mode ON	Powerful Mode ON
Light OFF	Operation OFF	Timer Setting OFF	Quiet Mode OFF	Powerful Mode OFF

Note:

- If POWER LED is blinking, the possible operation of the unit are Hot Start, during Deice operation, operation mode judgment, or ON timer sampling.
- If Timer LED is blinking, there is an abnormality operation occurs.

14. Protection Control (RE9SK and RE12SK)

14.1 Protection Control For All Operations

14.1.1 Restart Control (Time Delay Safety Control)

- The compressor will not turn on within 3 minutes from the moment operation stops, although the unit is turned on again by pressing OFF/ON button at remote control within this period.
- This control is not applicable if the power supply is cut off and on again.
- This phenomenon is to balance the pressure inside the refrigerant cycle.

14.1.2 30 Seconds Forced Operation

- Once the air conditioner is turned on, the compressor will not stop within 30 seconds in a normal operation although the intake air temperature has reached the thermo-off temperature. However, force stop by pressing the OFF/ON button at the remote control is permitted or the Auto OFF/ON button at indoor unit.
- The reason for the compressor to force operation for minimum 30 seconds is to allow the refrigerant oil run in a full cycle and return back to the outdoor unit.

14.1.3 Total Running Current Control

- When the outdoor unit total running current (AC) exceeds X value, the frequency instructed for compressor operation will be decreased.
- If the running current does not exceed X value for 5 seconds, the frequency instructed will be increased.
- However, if total outdoor unit running current exceeds Y value, compressor will be stopped immediately for 3 minutes.

Model		RE9SKUA	RE12SKUA
Cool (X)	A	4.30 A	6.76 A
	B	3.80 A	6.24 A
	C	3.80 A	5.80 A
Heat (X)		5.03 A	5.95 A
Y		14.80 A	14.80 A

1. The first 30 minutes of cooling operation, (A) will be applied.

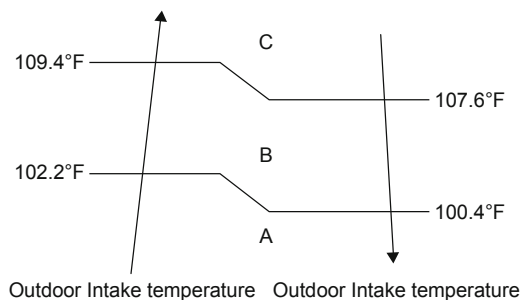

14.1.4 IPM (Power Transistor) Prevention Control

- Overheating Prevention Control
 - When the IPM temperature rises to 212°F, compressor operation will stop immediately.
 - Compressor operation restarts after 3 minutes the temperature decreases to 203°F.
 - If this condition repeats continuously 4 times within 20 minutes, timer LED will be blinking ("F96" is indicated).
- DC Peak Current Control
 - When electric current to IPM exceeds set value of 18.5A, the compressor will stop operate. Then, operation will restart after 3 minutes.
 - If the set value exceeds again more than 30 seconds after the compressor starts, the operation will restart after 2 minutes.
 - If the set value exceeds again within 30 seconds after the compressor starts, the operation will restart after 1 minute. If this condition repeats continuously for 7 times, all indoor and outdoor relays will be cut off, timer LED will be blinking ("F99" is indicated).

14.1.5 Compressor Overheating Prevention Control

- Instructed frequency for compressor operation will be regulated by compressor discharge temperature. The changes of frequency are as below.
- If compressor discharge temperature exceeds 224.6°F, compressor will be stopped, occurs 4 times per 20 minutes, timer LED will be blinking. ("F97" is indicated.)

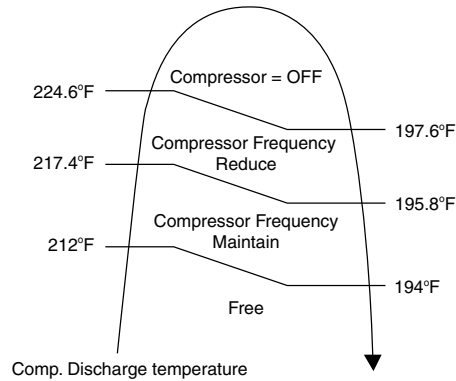

14.1.6 Low Pressure Prevention Control (Gas Leakage Detection)

- Control start conditions
 - For 5 minutes, the compressor continuously operates and outdoor total current is between 0.64A and 0.85A.
 - During Cooling and Soft Dry operations: Indoor suction temperature - indoor piping temperature is below 7.2.°F.
 - During Heating operations: Indoor piping temperature - indoor suction is under 9°F.
- Control contents
 - Compressor stops (and restart after 3 minutes).
 - If the conditions above happen 2 times within 20 minutes, the unit will:
 - Stop operation
 - Timer LED blinks and "F91" indicated.

14.1.7 Low Frequency Protection Control 1

- When the compressor operates at frequency lower than 24Hz continued for 240 minutes, the operation frequency will be changed to 25Hz for 2 minutes.

14.1.8 Low Frequency Protection Control 2

- When all below conditions comply, minimum limit of compressor will be set.

Temperature, T, for:	Cooling / Soft Dry	Heating
Indoor intake air (°F)	T < 57.2 or T ≥ 86	-
Outdoor air (°F)	T < 55.4 or T ≥ 100.4	T < 57.2 or T ≥ 82.4
Indoor heat exchanger (°F)	T < 86	T ≥ 32

14.2 Protection Control For Cooling & Soft Dry Operation

14.2.1 Outdoor Air Temperature Control

- The maximum current value is regulated when the outdoor air temperature rise above 57.2°F in order to avoid compressor overloading.

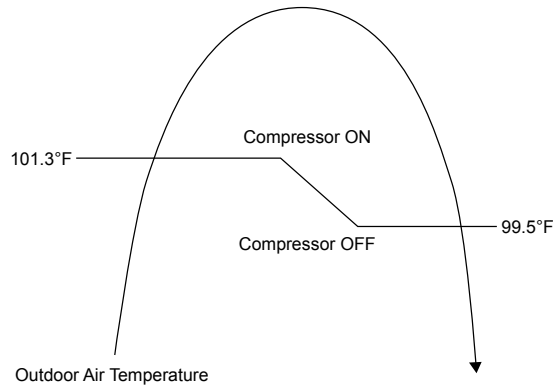

- The compressor will be stopped at outdoor air temperature $\leq -4^{\circ}\text{F}$. The unit still operate within the temperature range.

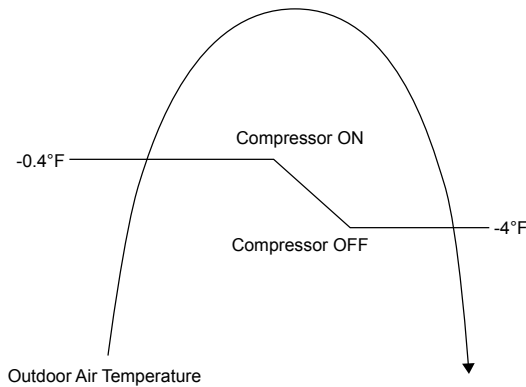

14.2.2 Cooling Overload Control

- Pipe temperature limitation / restriction.
 - Detects the outdoor pipe temperature and carry out restriction / limitation below (Limit the compressor operation frequency)
 - The compressor stops if outdoor pipe temperature exceeds 141.8°F.
 - If the compressor stops 4 times in 20 minutes, Timer LED blinks ("F95" indicated: Outdoor high pressure rise protection)

14.2.3 Freeze Prevention Control 1

- When indoor heat exchanger temperature is lower than 32°F continuously for 6 minutes, compressor will stops operation.
- Compressor will resume its operation 3 minutes after the indoor heat exchanger is higher than 41°F.
- At the same time, indoor fan speed will be higher than during its normal operation.
- If the indoor heat exchanger temperature is higher than 55.4°F for 5 minutes, the fan speed will return to its normal operation.

14.2.4 Freeze Prevention Control 2

- Control start conditions
 - During Cooling operation and soft dry operation
 - During thermo OFF condition, indoor intake temperature is less than 50°F or
 - Compressor stops for freeze prevention control
 - Either one of the conditions above occurs 5 times in 60 minutes.
- Control contents
 - Operation stops
 - Timer LED blinks and "H99" indicated

14.2.5 Dew Prevention Control 1

- To prevent dew formation at indoor unit discharge area.
- This control will be activated if:
 - Outdoor air temperature and Indoor pipe temperature judgment by microcontroller is fulfilled.
 - When Cooling or Dry mode is operated more than 20 minutes or more.
- This control stopped if:
 - Compressor stopped.
 - Remote control setting changed (fan speed / temperature).
 - Outdoor air temperature and indoor intake temperature changed.
- Fan speed, angle of louver (vertical airflow angle) will be adjusted accordingly in this control.
 1. Fan speed will be increased slowly when control is activated until predetermine value.
- Compressor frequency will be regulated accordingly.

14.2.6 Protection Control For Heating Operation

14.2.6.1 Intake Air Temperature Control

Compressor will operate at limited freq., if indoor intake air temperature is 86°F or above.

14.2.6.2 Outdoor Air Temperature Control

- The maximum current value is regulated when the outdoor air temperature rise above 57.2°F in order to avoid compressor overloading.

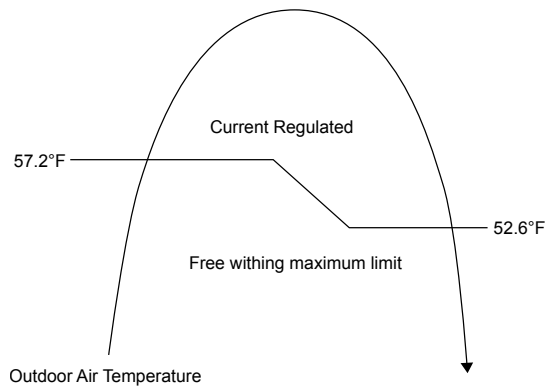

- The compressor will be stopped at outdoor air temperature $\leq -4^{\circ}\text{F}$. The unit still operate within the temperature range.

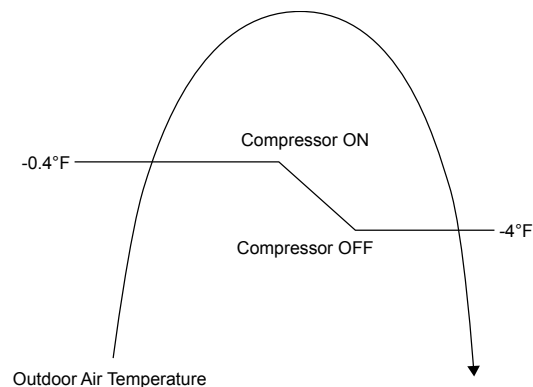

14.2.6.3 Overload Protection Control

- The compressor operating frequency is regulated in accordance to indoor heat exchanger temperature as shown below.
- If the heat exchanger temperature exceeds 140.0°F, compressor will stop.

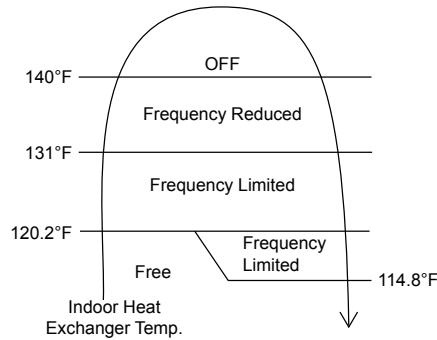

14.2.6.4 Low Temperature Compressor Oil Return Control

- In heating operation, if the outdoor temperature falls below 14°F when compressor starts, the compressor frequency will be regulated up to 600 seconds.

14.2.6.5 Cold Draught Prevention Control

- When indoor pipe temperature is low, cold draught operation starts where indoor fan speed will be reduced or stop.
- Horizontal vane angle may be adjusted in Auto vane setting.

14.2.6.6 Deice Operation

- When outdoor pipe temperature and outdoor air temperature is low, deice operation start where indoor fan motor and outdoor fan motor stop and operation LED blinks. Horizontal vane is closed during auto vane setting.

15. Protection Control (RE18SK and RE24SK)

15.1 Protection Control For All Operations

15.1.1 Restart Control (Time Delay Safety Control)

- The compressor will not turn on within 3 minutes from the moment operation stops, although the unit is turned on again by pressing OFF/ON button at remote control within this period.
- This control is not applicable if the power supply is cut off and on again.
- This phenomenon is to balance the pressure inside the refrigerant cycle.

15.1.2 30 Seconds Forced Operation

- Once the air conditioner is turned on, the compressor will not stop within 30 seconds in a normal operation although the intake air temperature has reached the thermo-off temperature. However, force stop by pressing the OFF/ON button at the remote control is permitted or the Auto OFF/ON button at indoor unit.
- The reason for the compressor to force operation for minimum 30 seconds is to allow the refrigerant oil run in a full cycle and return back to the outdoor unit.

15.1.3 Total Running Current Control

- When the outdoor unit total running current (AC) exceeds X value, the frequency instructed for compressor operation will be decreased.
- If the running current does not exceed X value for 5 seconds, the frequency instructed will be increased.
- However, if total outdoor unit running current exceeds Y value, compressor will be stopped immediately for 3 minutes.

Model		RE18SKUA	RE24SKUA
Cool (X)	A	11.05 A	12.25 A
	B	8.86 A	11.13 A
	C	8.86 A	11.13 A
Heat (X)		10.06 A	11.80 A
Y		14.74 A	14.74 A

1. The first 30 minutes of cooling operation, (A) will be applied.

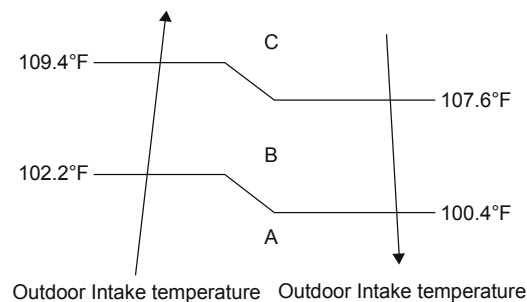

15.1.4 IPM (Power Transistor) Prevention Control

- Overheating Prevention Control
 - When the IPM temperature rises to 212°F, compressor operation will stop immediately.
 - Compressor operation restarts after 3 minutes the temperature decreases to 203°F.
- DC Peak Current Control
 - When electric current to IPM exceeds set value of 29.9A, the compressor will stop operate. Then, operation will restart after 3 minutes.
 - If the set value is exceeded again more than 30 seconds after the compressor starts, the operation will restart after 2 minute.
 - If the set value is exceeded again within 30 seconds after the compressor starts, the operation will restart after 1 minute. If this condition repeats continuously for 7 times, all indoor and outdoor relays will be cut off. Timer LED will be blinking (F99 is indicated).

15.1.5 Compressor Overheating Prevention Control

- Instructed frequency for compressor operation will be regulated by compressor discharge temperature. The changes of frequency are as below.
- If compressor discharge temperature exceeds 233.6°F, compressor will be stopped, occurs 4 times per 20 minutes, timer LED will be blinking. "F97" is indicated.

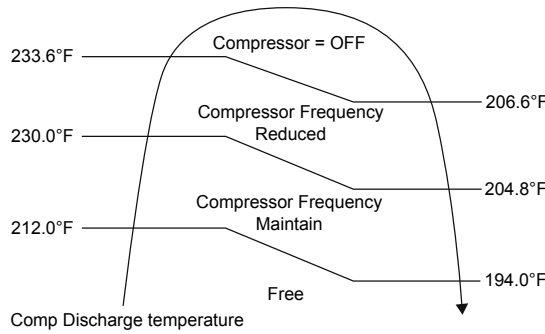

15.1.6 Low Pressure Protection Control (Gas Leakage Detection)

- For 5 minutes, the compressor continuously operates and outdoor total current is between 0.78A and 1.16A.
- During Cooling and Soft Dry operation:
Indoor suction temperature – indoor piping temperature is below 39.2°F.
- During Heating operations :
Indoor piping temperature - indoor suction is under 41.0°F.

15.1.7 Low Frequency Protection Control 1

- When the compressor operates at frequency lower than 25Hz continued for 240 minutes, the operation frequency will be changed to 24Hz for 2 minutes.

15.1.8 Low Frequency Protection Control 2

- When all below conditions comply, minimum limit of compressor will be set.

	RE18SKUA, RE24SKUA	
Temperature, T, for:	Cooling / Soft Dry	Heating
Indoor intake air (°F)	T < 57.2 or T ≥ 86.0	T < 57.2 or T ≥ 82.4
Outdoor air (°F)	T < 55.4 or T ≥ 100.4	T < 39.2 or T ≥ 75.2
Indoor heat exchanger (°F)	T < 86.0	T ≥ 32.0

15.2 Protection Control For Cooling & Soft Dry Operation

15.2.1 Outdoor Air Temperature Control

- The compressor operating frequency is regulated in accordance to the outdoor air temperature as shown in the diagram below.
- This control will begin 1 minute after the compressor starts.
- Compressor frequency will adjust based on outdoor air temperature.

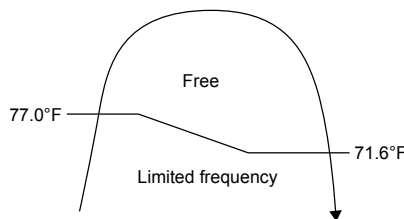

- The compressor will be stopped at outdoor air temperature $\leq -4^{\circ}\text{F}$. The unit still operate within the temperature range.

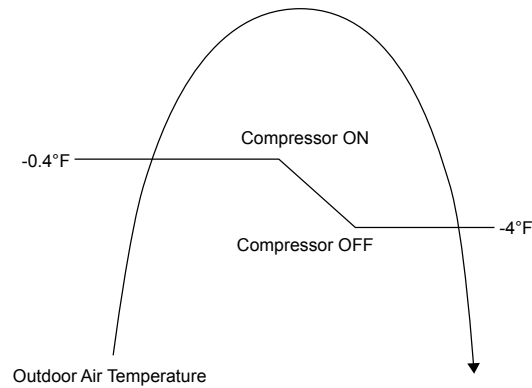

15.2.2 Cooling Overload Control

- Pipe temperature limitation / restriction.
 - Detects the outdoor pipe temperature and carry out restriction / limitation below (Limit the compressor operation frequency)
 - The compressor stops if outdoor pipe temperature exceeds 145.4°F .
 - If the compressor stops 4 times in 20 minutes, Timer LED blinks (“F95” indicated: Outdoor high pressure rise protection)

15.2.3 Freeze Prevention Control 1

- When indoor heat exchanger temperature is lower than 32°F continuously for 6 minutes, compressor will stops operation.
- Compressor will resume its operation 3 minutes after the indoor heat exchanger is higher than 41.0°F .
- At the same time, indoor fan speed will be higher than during its normal operation.
- If the indoor heat exchanger temperature is higher than 55.4°F for 5 minutes, the fan speed will return to its normal operation.

15.2.4 Freeze Prevention Control 2

- Control start conditions
 - During Cooling operation and soft dry operation
 - During thermo OFF condition, indoor intake temperature is less than 50.0°F or
 - Compressor stops for freeze prevention control
 - Either one of the conditions above occurs 5 times in 60 minutes.
- Control contents
 - Operation stops
 - Timer LED blinks and “H99” indicated

15.2.5 Dew Prevention Control 1

- To prevent dew formation at indoor unit discharge area.
- This control will be activated if:
 - Outdoor air temperature and Indoor pipe temperature judgment by microcontroller is fulfilled.
 - When Cooling or Dry mode is operated more than 20 minutes or more.
- This control stopped if:
 - Compressor stopped.
 - Remote control setting changed (fan speed / temperature).
 - Outdoor air temperature and indoor intake temperature changed.
- Fan speed, angle of louver (vertical airflow angle) will be adjusted accordingly in this control.
 1. Fan speed will be increased slowly when control is activated until predetermine value.
- Compressor frequency will be regulated accordingly.

15.2.6 Protection Control For Heating Operation

15.2.6.1 Intake Air Temperature Control

Compressor will operate at limited freq., if indoor intake air temperature is 86.0°F or above.

15.2.6.2 Outdoor Air Temperature Control

- The Max current value is regulated when the outdoor air temperature rise above 57.2°F in order to avoid compressor overloading.
- The compressor will be stopped at outdoor air temperature $\leq -4^\circ\text{F}$. The unit still operate within the temperature range.

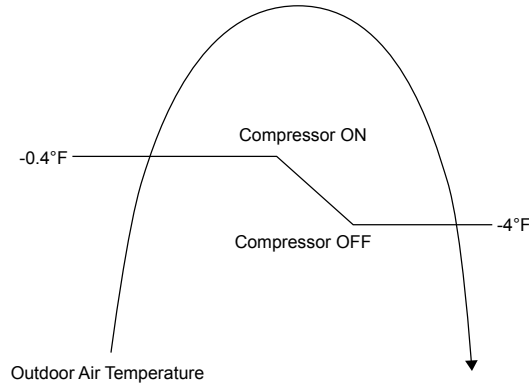

15.2.6.3 Overload Protection Control

- The compressor operating frequency is regulated in accordance to indoor heat exchanger temperature as shown below.
- If the heat exchanger temperature exceeds 140.0°F, compressor will stop.

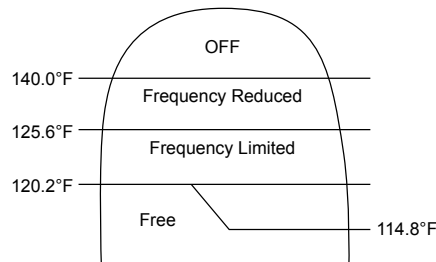

15.2.6.4 Low Temperature Compressor Oil Return Control

- In heating operation, if the indoor temperature falls below 17.6°F when compressor starts, the compressor frequency will be regulated up to 600 seconds.

15.2.6.5 Cold Draught Prevention Control

- When indoor pipe temperature is low, cold draught operation starts where indoor fan speed will be reduced or stop.
- Horizontal vane angle may be adjusted in Auto vane setting.

15.2.6.6 Deice Operation

When outdoor pipe temperature and outdoor air temperature is low, deice operation start where indoor fan motor and outdoor fan motor stop and operation LED blinks. Horizontal vane is closed during auto vane setting.

16. Servicing Mode

16.1 Auto Off/On Button

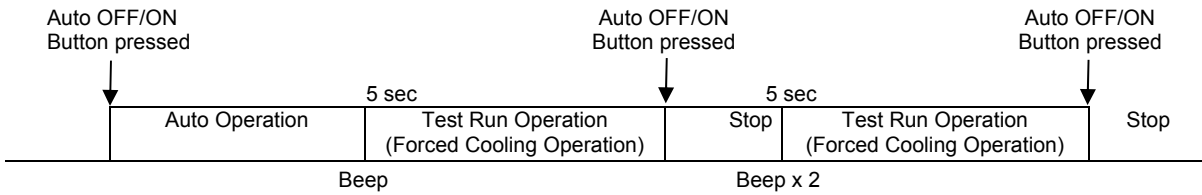

1 AUTO OPERATION MODE

The Auto operation will be activated immediately once the Auto OFF/ON button is pressed. This operation can be used to operate air conditioner with limited function if remote control is misplaced or malfunction.

2 TEST RUN OPERATION (FOR PUMP DOWN/SERVICING PURPOSE)

The Test Run operation will be activated if the Auto OFF/ON button is pressed continuously for more than 5 seconds. A “beep” sound will heard at the fifth seconds, in order to identify the starting of Test Run operation (Forced cooling operation). Within 5 minutes after Forced cooling operation start, the Auto OFF/ON button is pressed for more than 5 seconds. A 2 “beep” sounds will heard at the fifth seconds, in order to identify the starting of Forced heating operation.

The Auto OFF/ON button may be used together with remote control to set / change the advance setting of air conditioner operation.

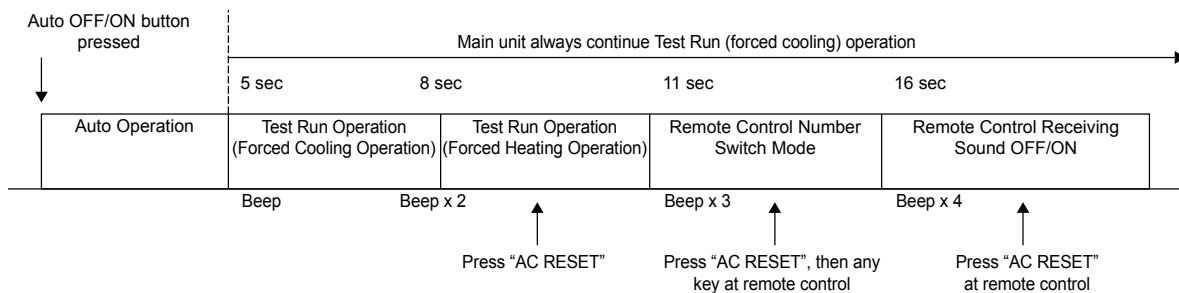

3 REMOTE CONTROL NUMBER SWITCH MODE

The Remote Control Number Switch Mode will be activated if the Auto OFF/ON button is pressed continuously for more than 11 seconds (3 “beep” sounds will occur at 11th seconds to identify the Remote Control Number Switch Mode is in standby condition) and press “AC RESET” button and then press any button at remote control to transmit and store the desired transmission code to the EEPROM.

There are 4 types of remote control transmission code could be selected and stored in EEPROM of indoor unit. The indoor unit will only operate when received signal with same transmission code from remote control. This could prevent signal interference when there are 2 or more indoor units installed nearby together. To change remote control transmission code, short or open jumpers at the remote control printed circuit board.

Remote Control Printed Circuit Board		
Jumper A (J1)	Jumper B (D2)	Remote Control No.
Short	Open	A (Default)
Open	Open	B
Short	Short	C
Open	Short	D

- During Remote Control Number Switch Mode, press any button at remote control to transmit and store the transmission code to the EEPROM.

4 REMOTE CONTROL RECEIVING SOUND OFF/ON MODE

The Remote Control Receiving Sound OFF/ON Mode will be activated if the Auto OFF/ON button is pressed continuously for more than 16 seconds (4 “beep” sounds will occur at 16th seconds to identify the Remote Control Receiving Sound OFF/ON Mode is in standby condition) and press “AC Reset” button at remote control.

Press Auto OFF/ON button to toggle remote control receiving sound.

- Short “beep”: Turn OFF remote control receiving sound.
- Long “beep”: Turn ON remote control receiving sound.

After Auto OFF/ON button is pressed, the 20 seconds counter for Remote Control Receiving Sound OFF/ON Mode is restarted.

16.2 Cooling Only Operation

16.2.1 How to activate and deactivate Cooling Only Operation

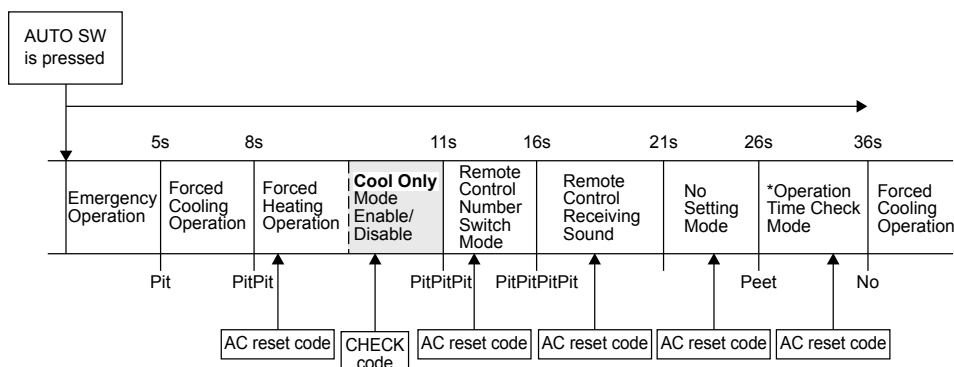

The default setting is "Cool Only" mode disable.

- To enable the "Cool Only" mode, press the AUTO OFF/ON SW for more than 8s and less than 11s, “Pit Pit” sound will be heard, then release the AUTO OFF/ON SW and press remote controller CHECK button. A short “Pit” sound will be heard. “Cool Only” mode is now enable.
- To disable the "Cool Only" mode, press the AUTO OFF/ON SW for more than 8s and less than 11s, “Pit Pit” sound will be heard, then release the AUTO OFF/ON SW and press remote controller CHECK button. A long "Pit" sound will be heard. “Cool Only” mode is now disable.

16.2.2 Operation mode during Cooling Only Operation

The table below shows the operation mode comparison when cooling only operation mode activated and deactivated.

Operation mode	Cooling Only Operation Mode Activated	Cooling Only Operation Mode Deactivated
AUTO	After 30s sampling, regardless of indoor intake or outdoor intake temperature judgement, the unit will run Cooling or DRY operation.	After 30s sampling, the unit will judge the operation mode base on remote controller temperature setting and Indoor Intake Sensor (New Auto Mode) or Outdoor Intake Sensor (Old Auto Mode)
HEAT	The unit will stop and Power LED blinking.	The unit will run Heating operation.
COOL	The unit will run Cooling operation.	The unit will run Cooling operation.
DRY	The unit will run DRY operation.	The unit will run Dry operation.
Force Heating	The unit will run Force Cooling operation.	The unit will run Force Heating operation.
AUTO (with Timer)	The unit will turn ON by the timer and run Auto Operation. After 30s sampling, regardless of indoor intake or outdoor intake temperature judgement, the unit will run Cooling or DRY operation.	The unit will turn ON by the timer and run Auto Operation. After 30s sampling, the unit will judge the operation mode base on remote controller temperature setting and Indoor Intake Sensor (New Auto Mode) or Outdoor Intake Sensor (Old Auto Mode)
HEAT (with Timer)	The unit will not turn ON by the Timer. Power LED blinking.	The unit will turn ON by the timer and run Heating Operation.
COOL (with Timer)	The unit will turn ON by the Timer and run Cooling operation.	The unit will turn ON by the timer and run Cooling Operation.
DRY (with Timer)	The unit will turn ON by the Timer and run DRY operation.	The unit will turn ON by the timer and run Cooling Dry Operation.

** Power LED blinking = 2.5s ON, 0.5s OFF

16.3 Remote Control Button

16.3.1 SET Button

- To check remote control transmission code and store the transmission code to EEPROM
 - Press “Set” button continuously for 10 seconds by using pointer
 - Press “Timer Set” button until a “beep” sound is heard as confirmation of transmission code change.

16.3.2 RESET (RC)

- To clear and restore the remote control setting to factory default.
 - Press once to clear the memory

16.3.3 RESET (AC)

- To restore the unit’s setting to factory default.
 - Press once to restore the unit’s setting

16.3.4 TIMER ▲

- To change indoor unit indicator’s LED intensity:
 - Press continuously for 5 seconds.

16.3.5 TIMER ▼

- To change remote control display from Degree Celsius (°C) to Degree Fahrenheit (°F)
 - Press continuously for 10 seconds.

16.3.6 CLOCK Button

- To change the remote control time format:
 - Press for more than 5 seconds

17. Troubleshooting Guide

17.1 Refrigeration Cycle System

In order to diagnose malfunctions, make sure that there are no electrical problems before inspecting the refrigeration cycle. Such problems include insufficient insulation, problem with the power source, malfunction of a compressor and a fan. The normal outlet air temperature and pressure of the refrigeration cycle depends on various conditions, the standard values for them are shown in the table on the right.

Normal Pressure and Outlet Air Temperature (Standard)

	Gas Pressure PSI (kg/cm ² G)	Outlet air Temperature (°F)
Cooling Mode	130.53 ~ 174.04 (9 ~ 12)	53.6 ~ 60.8
Heating Mode	333.58 ~ 420.60 (23 ~ 29)	96.8 ~ 113

Condition: Indoor fan speed = High
 Outdoor temperature 95°F at cooling mode
 and 44.6°F at heating mode.
 Compressor operate at rated frequency

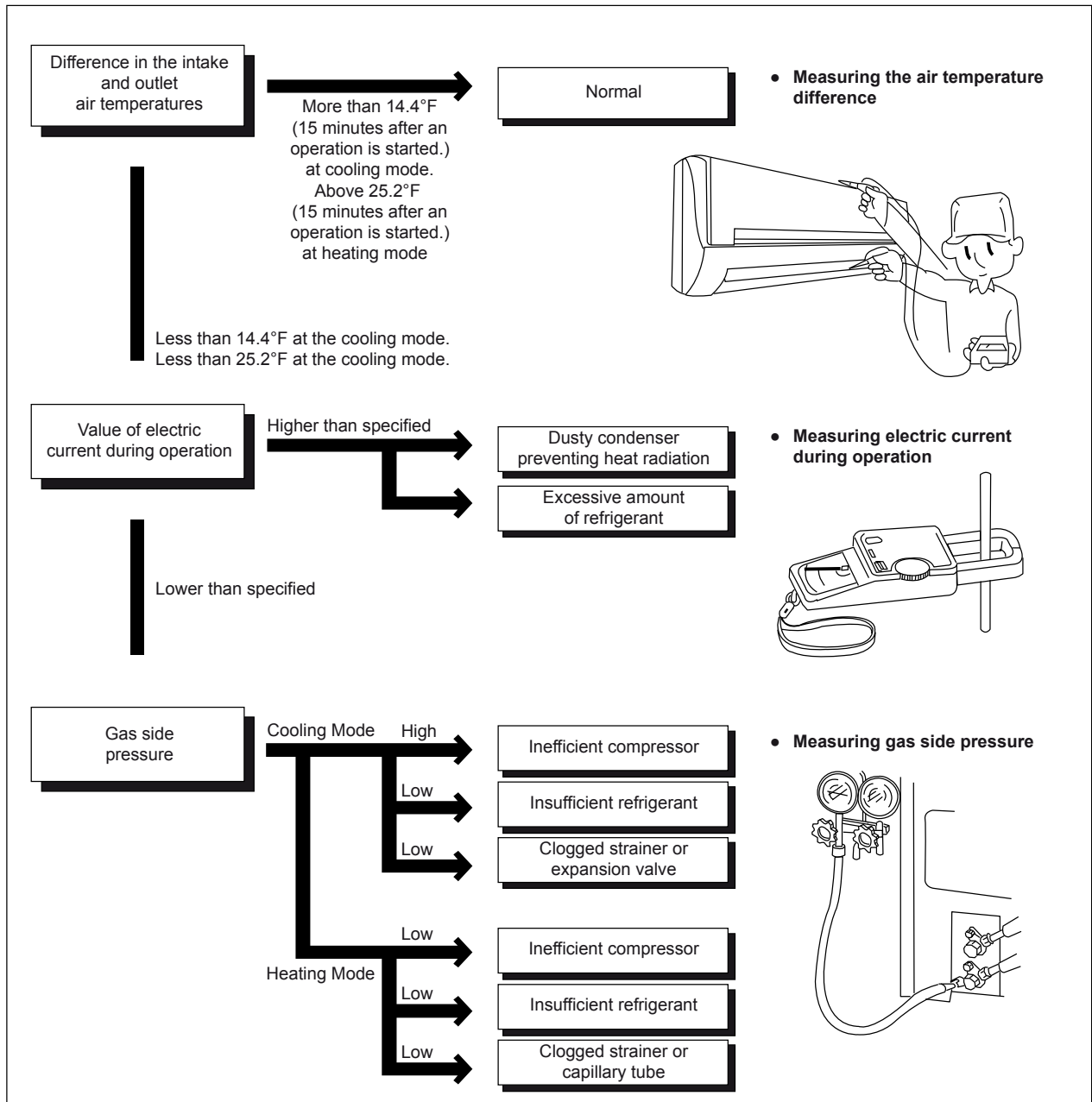

17.1.1 Relationship between the condition of the air conditioner and pressure and electric current

Condition of the air conditioner	Cooling Mode			Heating Mode		
	Low Pressure	High Pressure	Electric current during operating	Low Pressure	High Pressure	Electric current during operating
Insufficient refrigerant (gas leakage)	↘	↘	↘	↘	↘	↘
Clogged capillary tube or Strainer	↘	↘	↘	↘	↘	↘
Short circuit in the indoor unit	↘	↘	↘	↘	↘	↘
Heat radiation deficiency of the outdoor unit	↘	↘	↘	↘	↘	↘
Inefficient compression	↘	↘	↘	↘	↘	↘

- Carry out the measurements of pressure, electric current, and temperature fifteen minutes after an operation is started.

17.2 Breakdown Self Diagnosis Function

17.2.1 Self Diagnosis Function (Three Digits Alphanumeric Code)

- Once error occurred during operation, the unit will stop its operation, and Timer LED blinks.
- Although Timer LED goes off when power supply is turned off, if the unit is operated under a breakdown condition, the LED will ON again.
- In operation after breakdown repair, the Timer LED will not blink. The last error code (abnormality) will be stored in IC memory.

17.2.2 To Make a Diagnosis

1. Timer LED starts to blink and the unit automatically stops the operation.
2. Press the CHECK button on the remote control continuously for 5 seconds.
3. “- -” will be displayed on the remote control display.
Note: Display only for “- -” (No signal transmission, no receiving sound and no Power LED blinking)
4. Press the TIMER ▲ or ▼ button on the remote control. The code “H00” (no abnormality) will be displayed and signal will be transmit to the main unit.
5. Each press of the button (▲ or ▼) will increase error code number and transmit error code signal to the main unit.
6. When the latest abnormality code on the main unit and code transmitted from the remote control are matched, Power LED will light up for 30 seconds and a “beep” sound (continuously for 4 seconds) will be heard. If no codes are matched, Power LED will light up for 0.5 seconds and no sound will be heard.
7. The breakdown diagnosis mode will be canceled unless pressing the CHECK button continuously for 5 seconds or operating the unit for 30 seconds.
8. The LED will be off if the unit is turned off or the RESET button on the main unit is pressed.

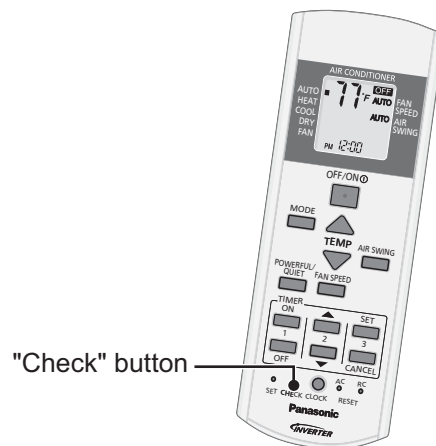

17.2.3 To Display Memorized Error Code (Protective Operation)

- 1 Turn power on.
- 2 Press the CHECK button on the remote control
- 3 “- -” will be displayed on the remote control display.
Note: Display only for “- -” (No signal transmission, no receiving sound and no Power LED blinking)
- 4 Press the TIMER ▲ or ▼ button on the remote control. The code “H00” (no abnormality) will be displayed and signal will be transmit to the main unit.
- 5 Each press of the button (▲ or ▼) will increase error code number and transmit error code signal to the main unit.
- 6 When the latest abnormality code on the main unit and code transmitted from the remote control are matched, Power LED will light up for 30 seconds and a “beep” sound (continuously for 4 seconds) will be heard. If no codes are matched, Power LED will light up for 0.5 seconds and no sound will be heard.
- 7 The breakdown diagnosis mode will be canceled unless pressing the CHECK button continuously for 5 seconds or operating the unit for 30 seconds.
- 8 The same diagnosis can be repeated by turning power on again.

17.2.4 To Clear Memorized Error Code after Repair (Protective Operation)

- 1 Turn power on (in standby condition).
- 2 Press the AUTO button for 5 seconds (a “beep” sound is heard) on the main unit to operate the unit at Forced Cooling Operation Mode.
- 3 Press the CHECK button on the remote control for about 1 second with a pointed object to transmit signal to main unit. A “beep” sound is heard, and the Error Code is cleared.

17.2.5 Temporary Operation (Depending On Breakdown Status)

- 1 Press the Auto OFF/ON button on the main unit (a “beep” sound is heard) to operate the unit. (Remote control is enable again).
- 2 The unit can be temporarily be used until repaired.

Error Code	Operation	Temporary items
H23	Cooling	Emergency Operation with limited power
H27, H28	Cooling, Heating	

17.3 Error Code Table

Diagnosis display	Abnormality / Protection control	Abnormality Judgement	Protection operation	Problem	Check location
H00	No memory of failure	—	Normal operation	—	—
H11	Indoor/outdoor abnormal communication	After operation for 1 minute	Indoor fan only operation can start by entering into force cooling operation	Indoor/outdoor communication not establish	<ul style="list-style-type: none"> Indoor/outdoor wire terminal Indoor/outdoor PCB Indoor/outdoor connection wire
H12	Indoor unit capacity unmatched	90s after power supply	—	Total indoor capability more than maximum limit or less than minimum limit, or number of indoor unit less than two.	<ul style="list-style-type: none"> Indoor/outdoor connection wire Indoor/outdoor PCB Specification and combination table in catalogue
H14	Indoor intake air temperature sensor abnormality	Continuous for 5s	—	Indoor intake air temperature sensor open or short circuit	Indoor intake air temperature sensor lead wire and connector
H15	Compressor temperature sensor abnormality	Continuous for 5s	—	Compressor temperature sensor open or short circuit	Compressor temperature sensor lead wire and connector
H16	Outdoor current transformer (CT) abnormality	—	—	Current transformer faulty or compressor faulty	Outdoor PCB faulty or compressor faulty
H19	Indoor fan motor mechanism lock	Continuous happen for 7 times	—	Indoor fan motor lock or feedback abnormal	<ul style="list-style-type: none"> Fan motor lead wire and connector Fan motor lock or block
H23	Indoor heat exchanger temperature sensor abnormality	Continuous for 5s	—	Indoor heat exchanger temperature sensor open or short circuit	Indoor heat exchanger temperature sensor lead wire and connector
H24	Indoor heat exchanger temperature sensor 2 abnormality	Continuous for 5s	—	Indoor heat exchanger temperature sensor 2 open or short circuit	Indoor heat exchanger temperature sensor 2 lead wire and connector
H27	Outdoor air temperature sensor abnormality	Continuous for 5s	—	Outdoor air temperature sensor open or short circuit	Outdoor air temperature sensor lead wire and connector
H28	Outdoor heat exchanger temperature sensor 1 abnormality	Continuous for 5s	—	Outdoor heat exchanger temperature sensor 1 open or short circuit	Outdoor heat exchanger temperature sensor 1 lead wire and connector
H30	Outdoor discharge pipe temperature sensor abnormality	Continuous for 5s	—	Outdoor discharge pipe temperature sensor open or short circuit	Outdoor discharge pipe temperature sensor lead wire and connector
H32	Outdoor heat exchanger temperature sensor 2 abnormality	Continuous for 5s	—	Outdoor heat exchanger temperature sensor 2 open or short circuit	Outdoor heat exchanger temperature sensor 2 lead wire and connector
H33	Indoor / outdoor misconnection abnormality	—	—	Indoor and outdoor rated voltage different	Indoor and outdoor units check
H36	Outdoor gas pipe temperature sensor abnormality	Continuous for 5s	Heating protection operation only	Outdoor gas pipe temperature sensor open or short circuit	Outdoor gas pipe temperature sensor lead wire and connector
H37	Outdoor liquid pipe temperature sensor abnormality	Continuous for 5s	Cooling protection operation only	Outdoor liquid pipe temperature sensor open or short circuit	Outdoor liquid pipe temperature sensor lead wire and connector
H38	Indoor/Outdoor mismatch (brand code)	—	—	Brand code not match	Check indoor unit and outdoor unit.
H39	Abnormal indoor operating unit or standby units	3 times happen within 40 minutes	—	Wrong wiring and connecting pipe, expansion valve abnormality, indoor heat exchanger sensor open circuit	<ul style="list-style-type: none"> Check the indoor/outdoor connection wire and connection pipe. Indoor heat exchanger sensor lead wire and connector. Expansion valve and lead wire and connector system.
H41	Abnormal wiring or piping connection	—	—	Wrong wiring and connecting pipe, expansion valve abnormality	<ul style="list-style-type: none"> Check indoor/outdoor connection wire and connection pipe Expansion valve and lead wire and connector

Diagnosis display	Abnormality / Protection control	Abnormality Judgement	Protection operation	Problem	Check location
H59	ECONAVI sensor abnormality	Continuous for 25s	—	ECONAVI sensor open or short circuit	<ul style="list-style-type: none"> ECONAVI sensor (defective or disconnected) ECONAVI PCB
H64	Outdoor high pressure sensor abnormality	Continuous for 1 minutes	—	High pressure sensor open circuit during compressor	<ul style="list-style-type: none"> High pressure sensor Lead wire and connector
H97	Outdoor fan motor mechanism lock	2 times happen within 30 minutes	—	Outdoor fan motor lock or feedback abnormal	<ul style="list-style-type: none"> Outdoor fan motor lead wire and connector Fan motor lock or block
H98	Indoor high pressure protection	—	—	Indoor high pressure protection (Heating)	<ul style="list-style-type: none"> Check indoor heat exchanger Air filter dirty Air circulation short circuit
H99	Indoor operating unit freeze protection	—	—	Indoor freeze protection (Cooling)	<ul style="list-style-type: none"> Check indoor heat exchanger Air filter dirty Air circulation short circuit
F11	4-way valve switching abnormality	4 times happen within 30 minutes	—	4-way valve switching abnormal	<ul style="list-style-type: none"> 4-way valve Lead wire and connector.
F17	Indoor standby units freezing abnormality	3 times happen within 40 minutes	—	Wrong wiring and connecting pipe, expansion valve leakage, indoor heat exchanger sensor open circuit	<ul style="list-style-type: none"> Check indoor/outdoor connection wire and pipe Indoor heat exchanger sensor lead wire and connector Expansion valve lead wire and connector.
F90	Power factor correction (PFC) circuit protection	4 times happen within 10 minutes	—	Power factor correction circuit abnormal	<ul style="list-style-type: none"> Outdoor PCB faulty
F91	Refrigeration cycle abnormality	2 times happen within 20 minutes	—	Refrigeration cycle abnormal	<ul style="list-style-type: none"> Insufficient refrigerant or valve close
F93	Compressor abnormal revolution	4 times happen within 20 minutes	—	Compressor abnormal revolution	<ul style="list-style-type: none"> Power transistor module faulty or compressor lock
F94	Compressor discharge overshoot protection	4 times happen within 30 minutes	—	Compressor discharge pressure overshoot	<ul style="list-style-type: none"> Check refrigeration system
F95	Outdoor cooling high pressure protection	4 times happen within 20 minutes	—	Cooling high pressure protection	<ul style="list-style-type: none"> Check refrigeration system Outdoor air circuit
F96	Power transistor module overheating protection	4 times happen within 30 minutes	—	Power transistor module overheat	<ul style="list-style-type: none"> PCB faulty Outdoor air circuit (fan motor)
F97	Compressor overheating protection	3 times happen within 30 minutes	—	Compressor overheat	<ul style="list-style-type: none"> Insufficient refrigerant
F98	Total running current protection	3 times happen within 20 minutes	—	Total current protection	<ul style="list-style-type: none"> Check refrigeration system Power source or compressor lock
F99	Outdoor direct current (DC) peak detection	Continuous happen for 7 times	—	Power transistor module current protection	<ul style="list-style-type: none"> Power transistor module faulty or compressor lock

Note:

“o” – Frequency measured and fan speed fixed

The memory data of error code is erased when the power supply is cut off, or press the Auto Switch until “beep” sound heard following by pressing the CHECK button at remote control.

Although operation forced to stop when abnormality detected, emergency operation is possible for certain errors (refer to Error Code Table) by using remote control or Auto OFF/ON button at indoor unit. However, the remote control signal receiving sound is changed from one “beep” to four “beep” sounds.

17.4 Self-diagnosis Method

17.4.1 H11 (Indoor/Outdoor Abnormal Communication)

Malfunction Decision Conditions

- During startup and operation of cooling and heating, the data received from outdoor unit in indoor unit signal transmission is checked whether it is normal.

Malfunction Caused

- Faulty indoor unit PCB.
- Faulty outdoor unit PCB.
- Indoor unit-outdoor unit signal transmission error due to wrong wiring.
- Indoor unit-outdoor unit signal transmission error due to breaking of wire in the connection wires between the indoor and outdoor units.
- Indoor unit-outdoor unit signal transmission error due to disturbed power supply waveform.

Troubleshooting

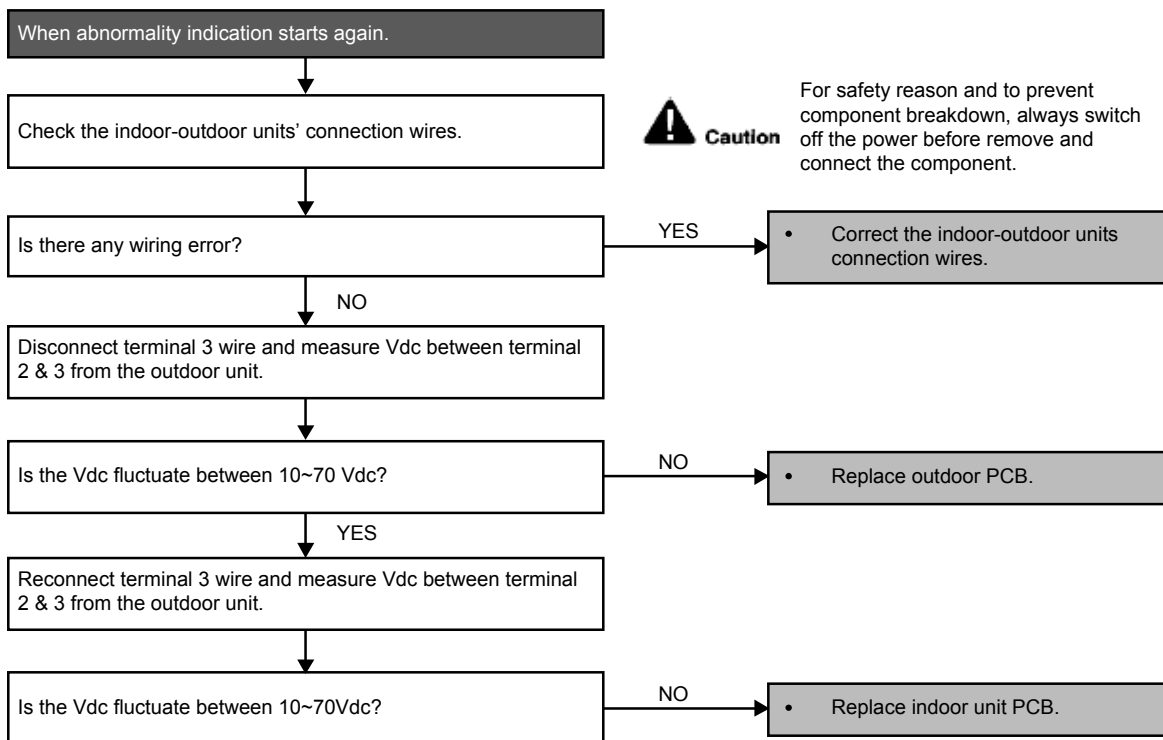

17.4.2 H12 (Indoor/Outdoor Capacity Rank Mismatched)

Malfunction Decision Conditions

- During startup, error code appears when different types of indoor and outdoor units are interconnected.

Malfunction Caused

- Wrong models interconnected.
- Wrong indoor unit or outdoor unit PCBs mounted.
- Indoor unit or outdoor unit PCBs defective.
- Indoor-outdoor unit signal transmission error due to wrong wiring.
- Indoor-outdoor unit signal transmission error due to breaking of wire 3 in the connection wires between the indoor and outdoor units.

Troubleshooting

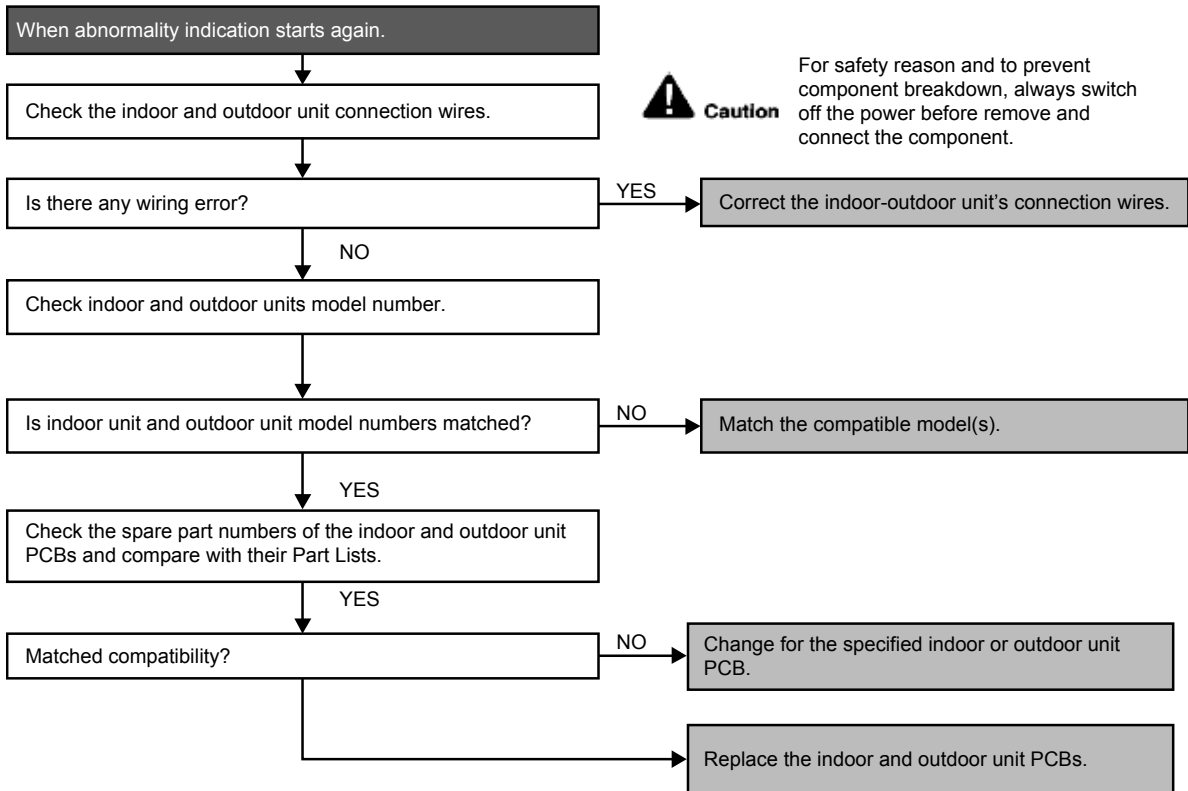

17.4.3 H14 (Indoor Intake Air Temperature Sensor Abnormality)

Malfunction Decision Conditions

- During startup and operation of cooling and heating, the temperatures detected by the indoor intake air temperature sensor are used to determine sensor errors.

Malfunction Caused

- Faulty connector connection.
- Faulty sensor.
- Faulty PCB.

Troubleshooting

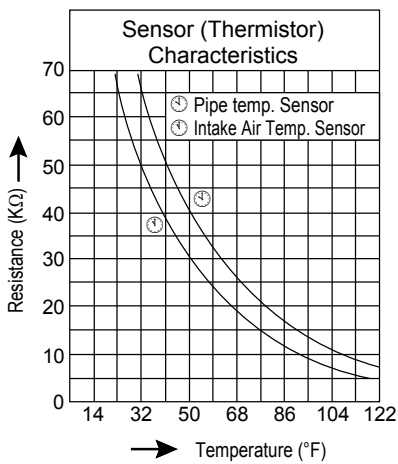
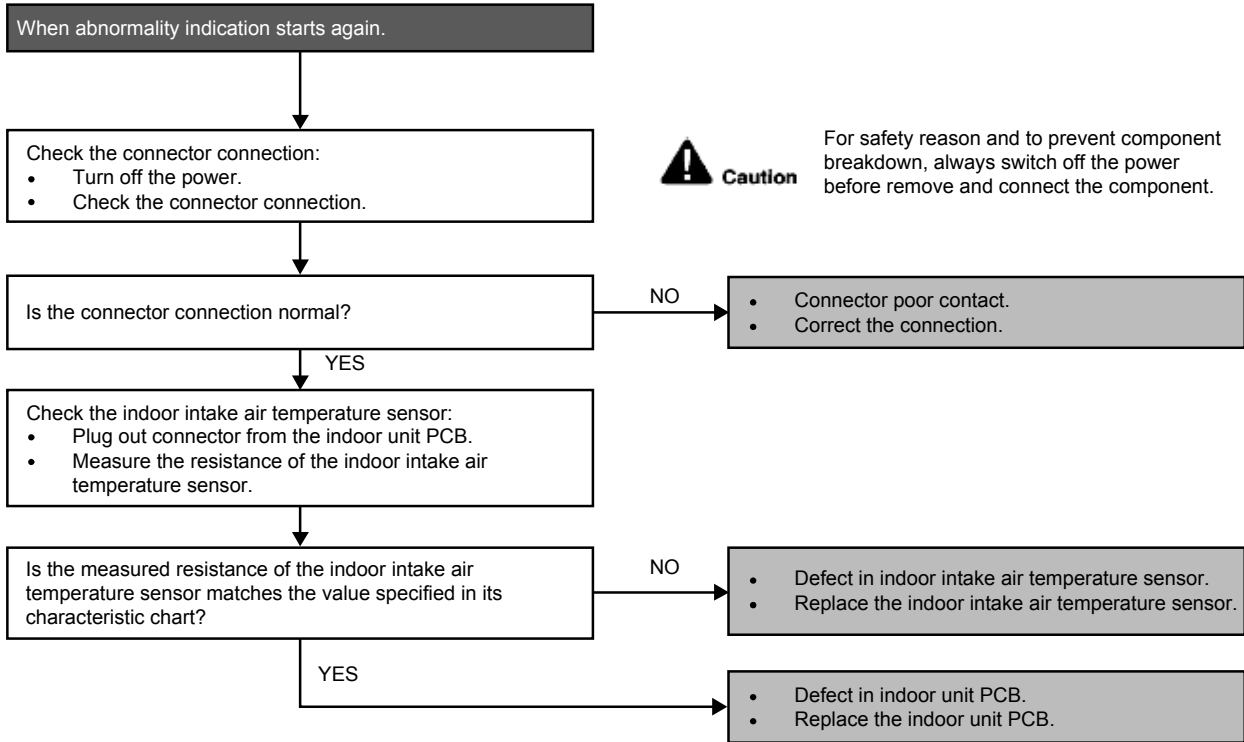

17.4.4 H15 (Compressor Temperature Sensor Abnormality)

Malfunction Decision Conditions

- During startup and operation of cooling and heating, the temperatures detected by the outdoor compressor temperature sensor are used to determine sensor errors.

Malfunction Caused

- Faulty connector connection.
- Faulty sensor.
- Faulty PCB.

Troubleshooting

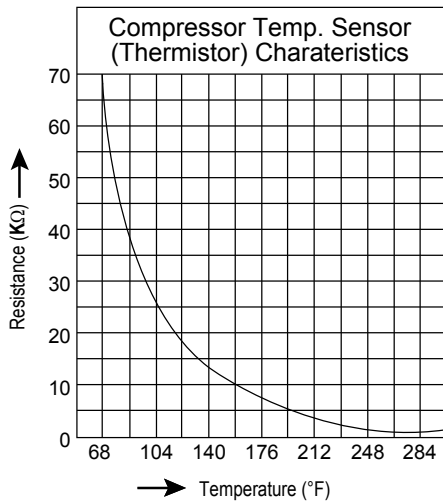
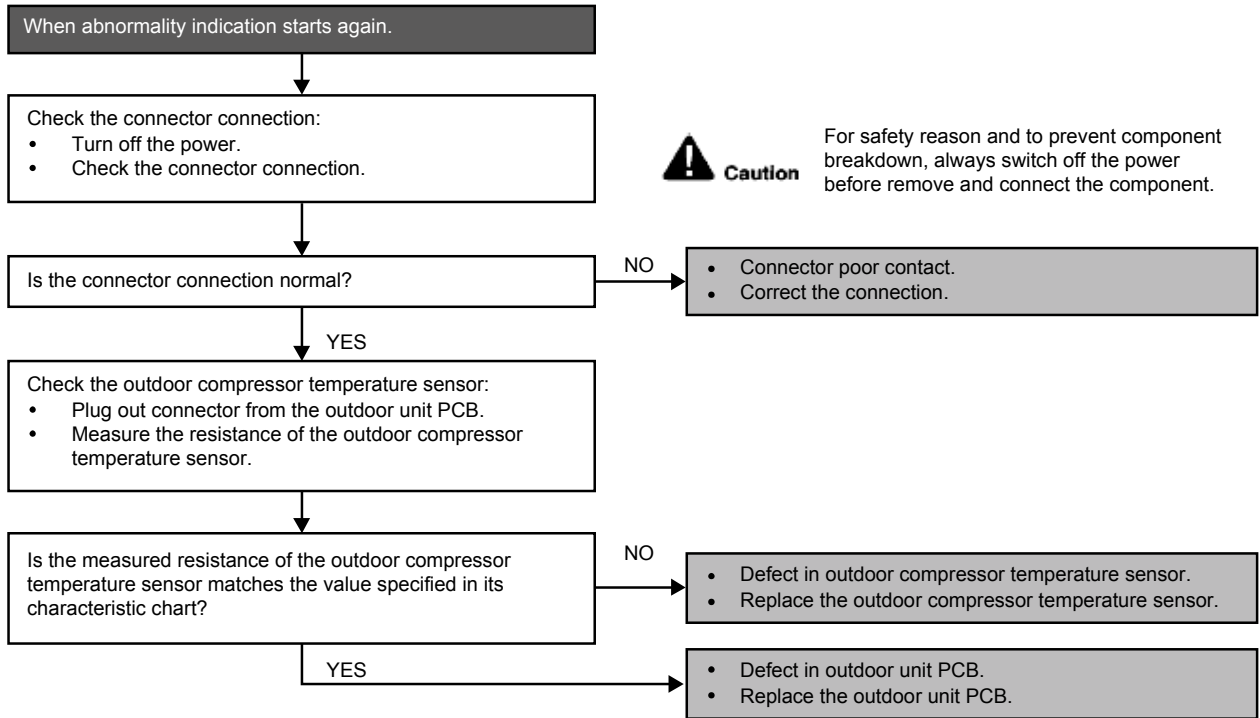

17.4.5 H16 (Outdoor Current Transformer)

Malfunction Decision Conditions

- An input current, detected by Current Transformer CT, is below threshold value when the compressor is operating at certain frequency value for 3 minutes.

Malfunction Caused

- Lack of gas.
- Broken CT (current transformer).
- Broken Outdoor PCB.

Troubleshooting

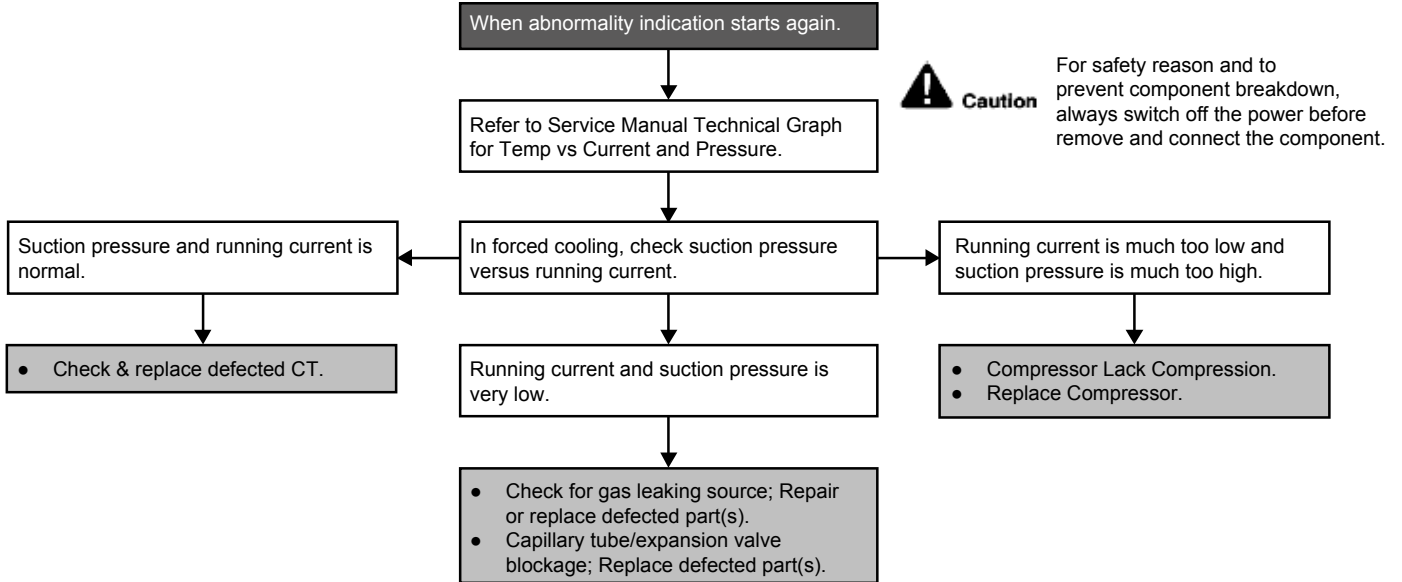

17.4.6 H19 (Indoor Fan Motor – DC Motor Mechanism Locked)

Malfunction Decision Conditions

- The rotation speed detected by the Hall IC during fan motor operation is used to determine abnormal fan motor (feedback of rotation > 2550rpm or < 50rpm)

Malfunction Caused

- Operation stops due to short circuit inside the fan motor winding.
- Operation stops due to breaking of wire inside the fan motor.
- Operation stops due to breaking of fan motor lead wires.
- Operation stops due to Hall IC malfunction.
- Operation error due to faulty indoor unit PCB.

Troubleshooting

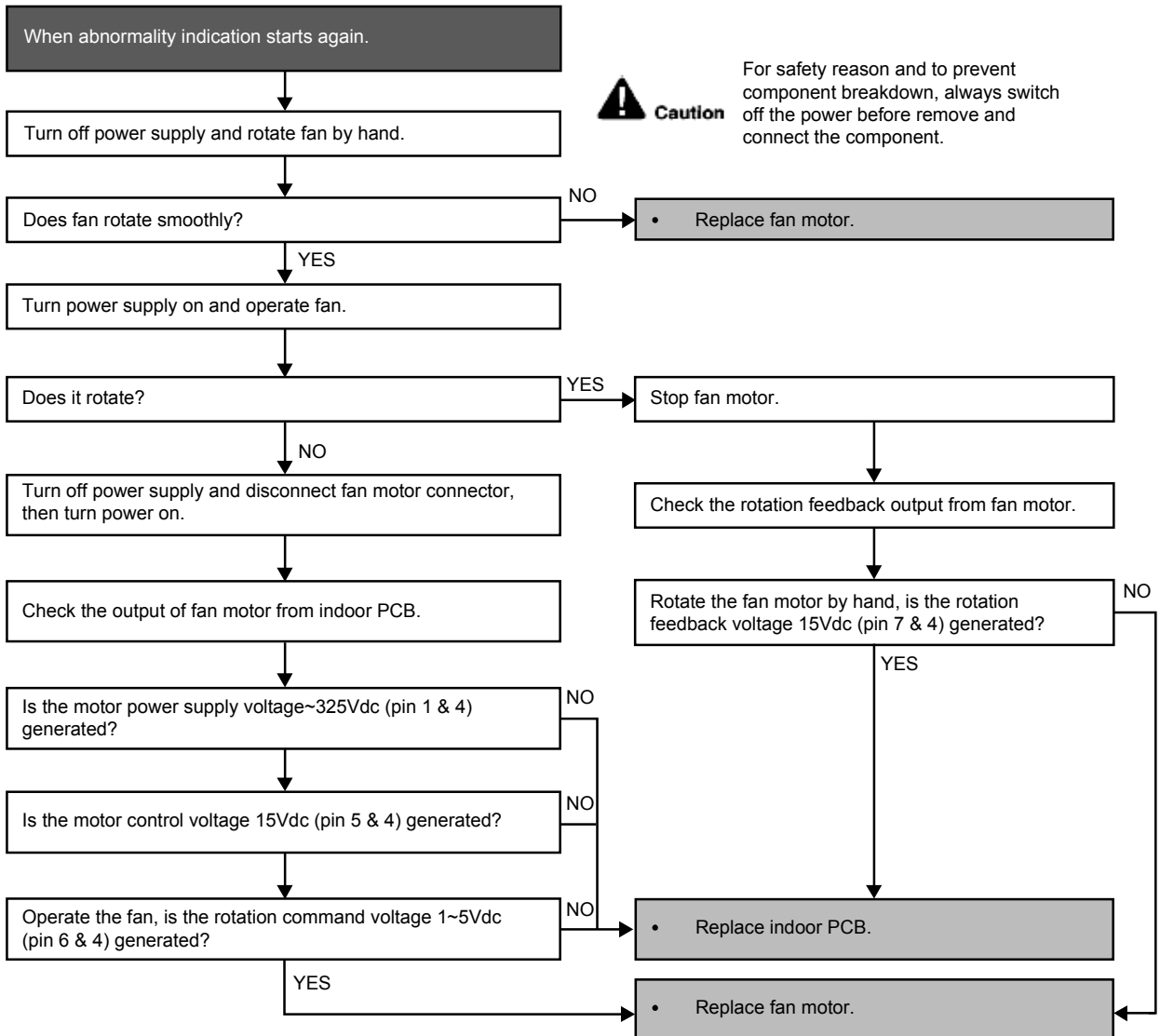

17.4.7 H23 (Indoor Pipe Temperature Sensor Abnormality)

Malfunction Decision Conditions

- During startup and operation of cooling and heating, the temperatures detected by the indoor heat exchanger temperature sensor are used to determine sensor errors.

Malfunction Caused

- Faulty connector connection.
- Faulty sensor.
- Faulty PCB.

Troubleshooting

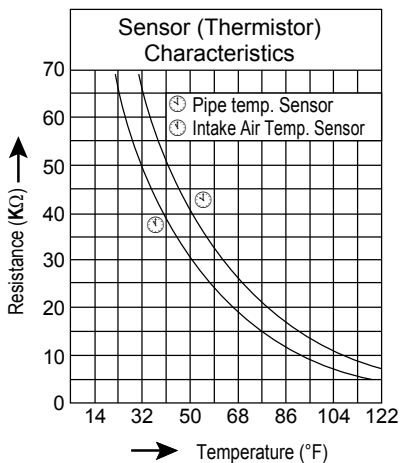
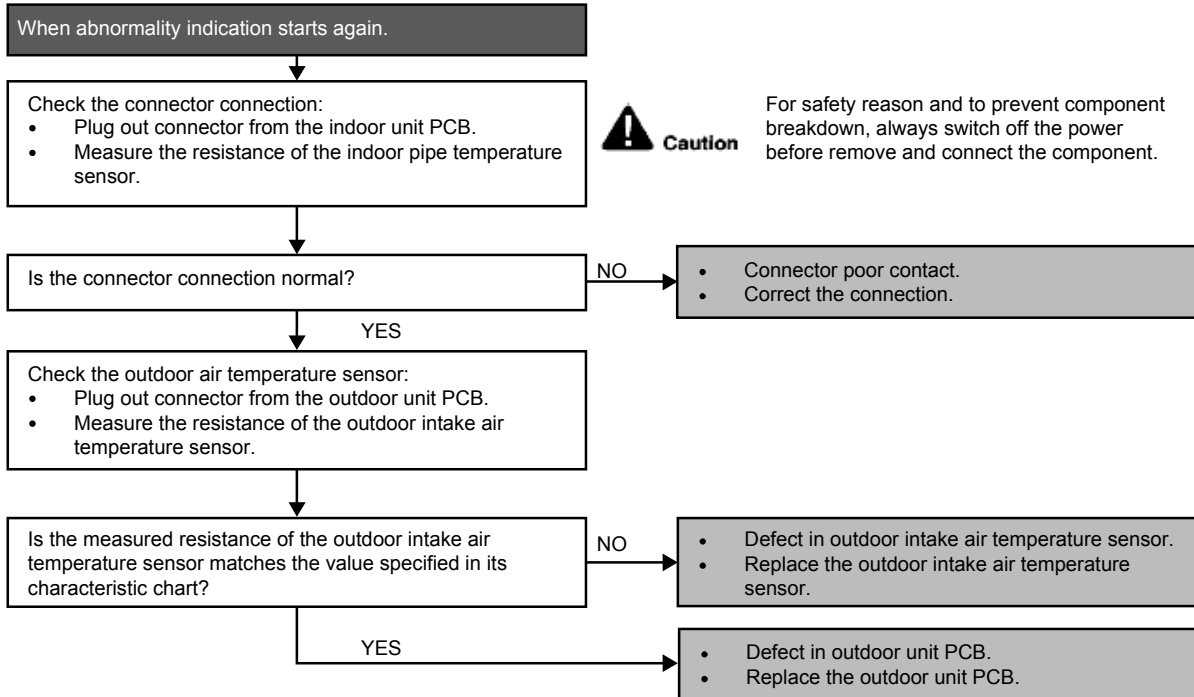

17.4.8 H27 (Outdoor Air Temperature Sensor Abnormality)

Malfunction Decision Conditions

- During startup and operation of cooling and heating, the temperatures detected by the outdoor air temperature sensor are used to determine sensor errors.

Malfunction Caused

- Faulty connector connection.
- Faulty sensor.
- Faulty PCB.

Troubleshooting

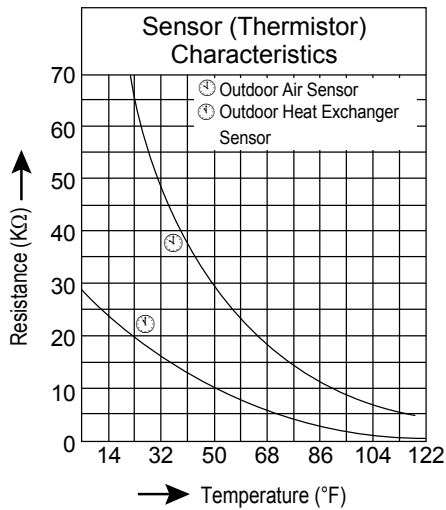
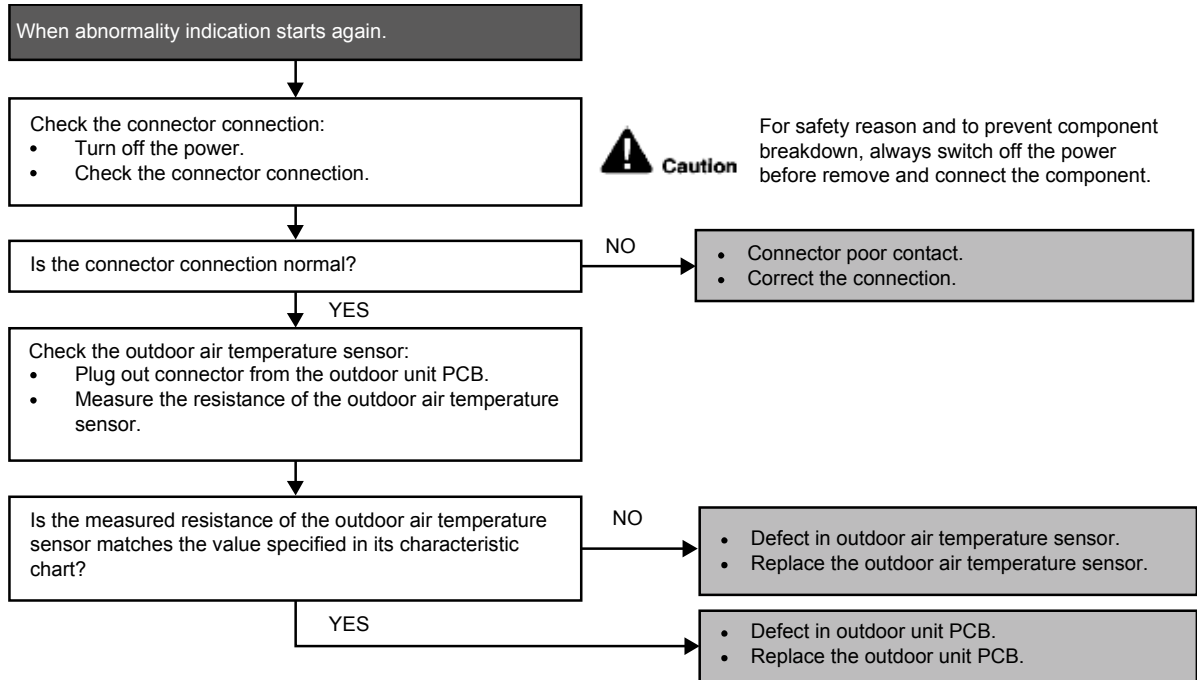

17.4.9 H28 (Outdoor Pipe Temperature Sensor Abnormality)

Malfunction Decision Conditions

- During startup and operation of cooling and heating, the temperatures detected by the outdoor pipe temperature sensor are used to determine sensor errors.

Malfunction Caused

- Faulty connector connection.
- Faulty sensor.
- Faulty PCB.

Troubleshooting

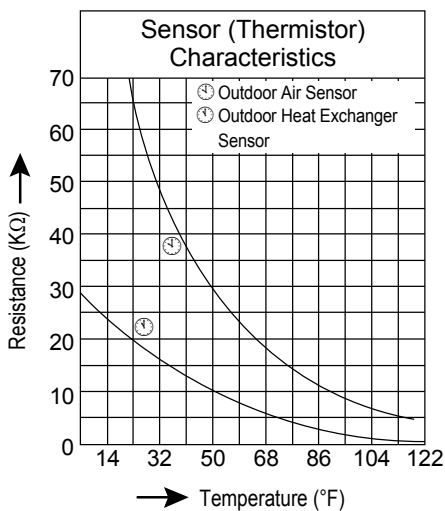
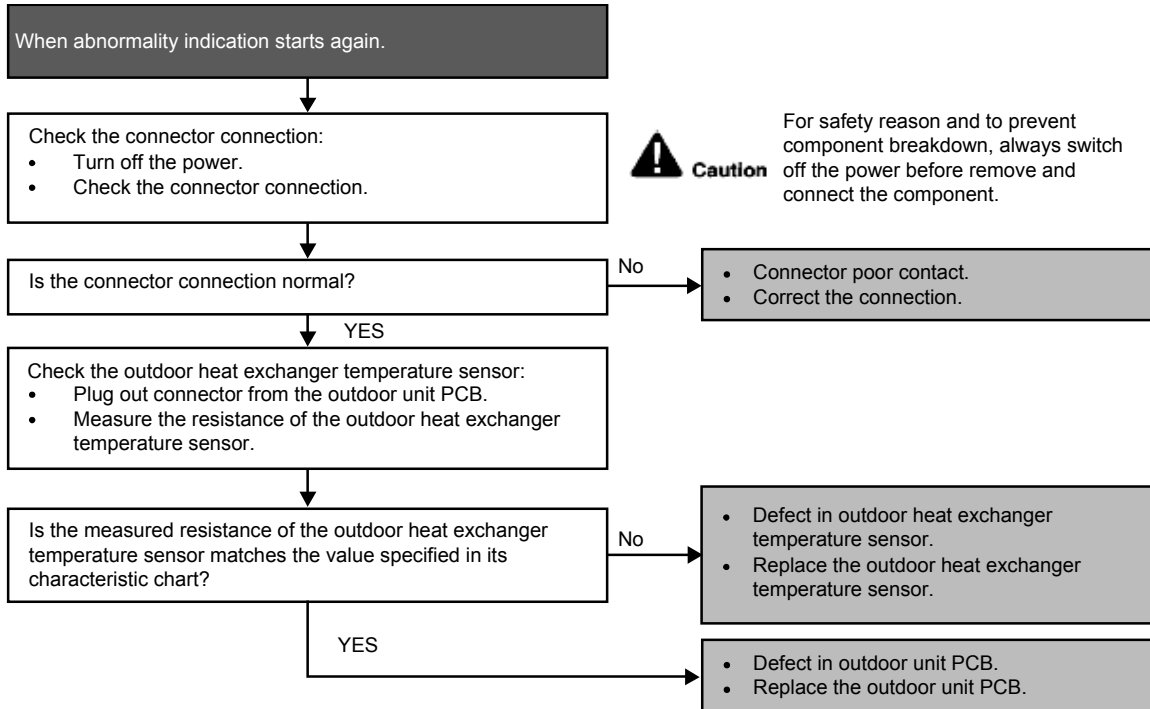

17.4.10 H30 (Compressor Discharge Temperature Sensor Abnormality)

Malfunction Decision Conditions

- During startup and operation of cooling and heating, the temperatures detected by the outdoor discharge pipe temperature sensor are used to determine sensor errors.

Malfunction Caused

- Faulty connector connection.
- Faulty sensor.
- Faulty PCB.

Troubleshooting

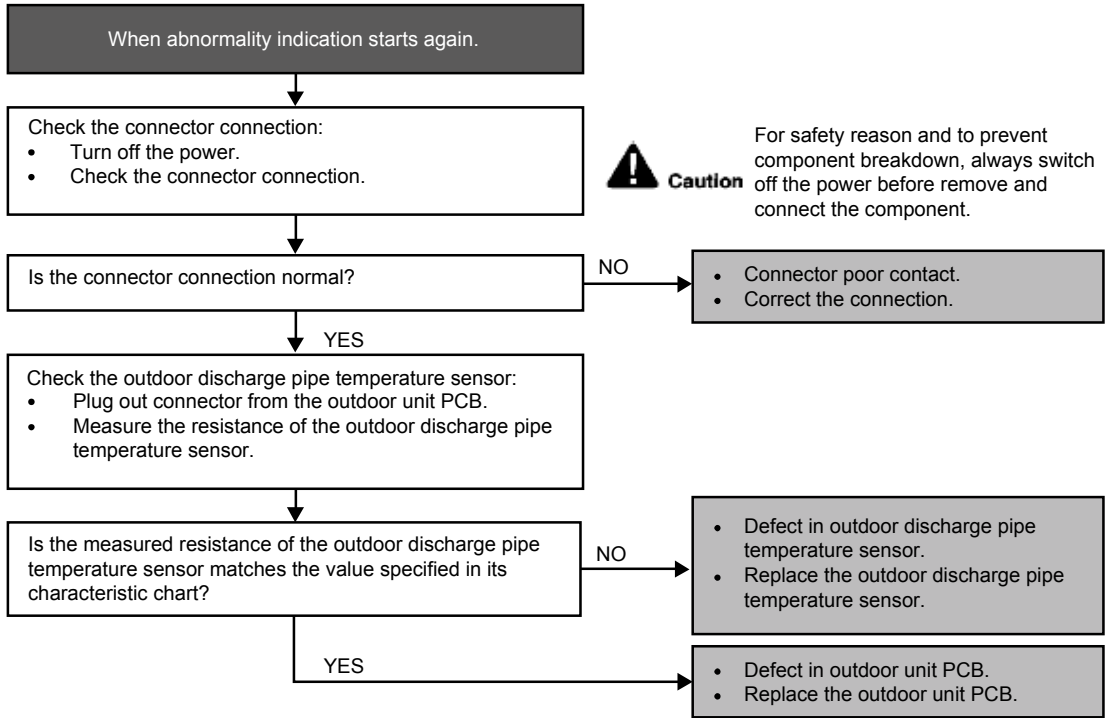

17.4.11 H32 (Outdoor Heat Exchanger Temperature Sensor 2 Abnormality)

Malfunction Decision Conditions

- During startup and operation of cooling and heating, the temperatures detected by the outdoor heat exchanger temperature sensor are used to determine sensor errors.

Malfunction Caused

- Faulty connector connection.
- Faulty sensor.
- Faulty PCB.

Troubleshooting

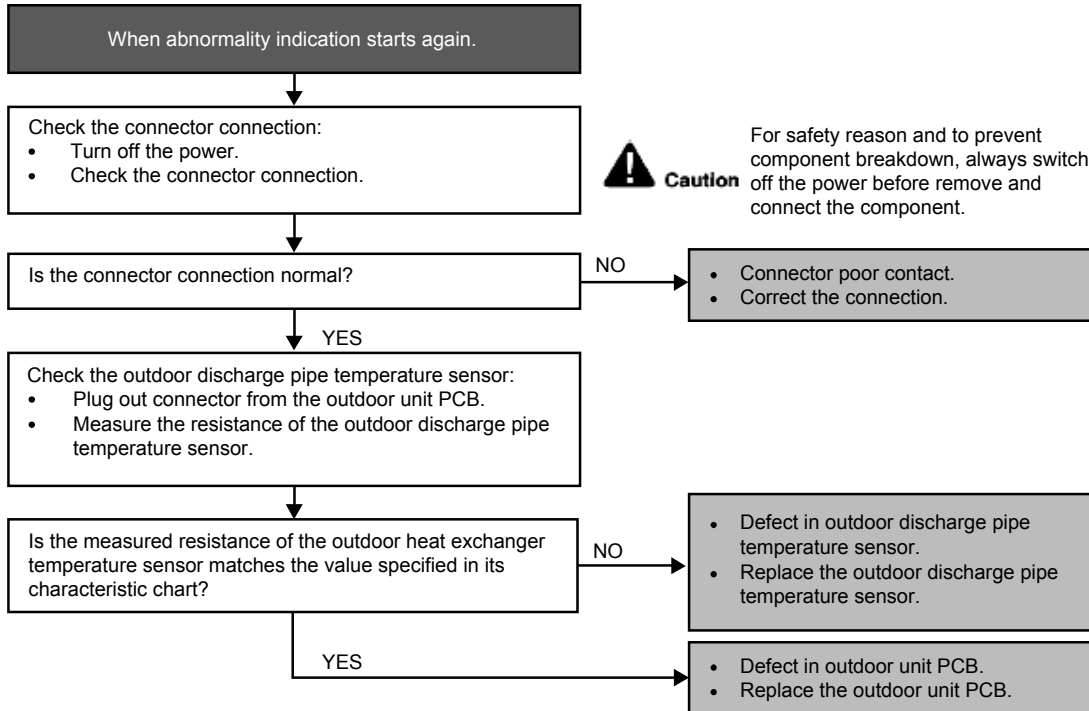

17.4.12 H33 (Unspecified Voltage between Indoor and Outdoor)

Malfunction Decision Conditions

- The supply power is detected for its requirement by the indoor/outdoor transmission.

Malfunction Caused

- Wrong models interconnected.
- Wrong indoor unit and outdoor unit PCBs used.
- Indoor unit or outdoor unit PCB defective.

Troubleshooting

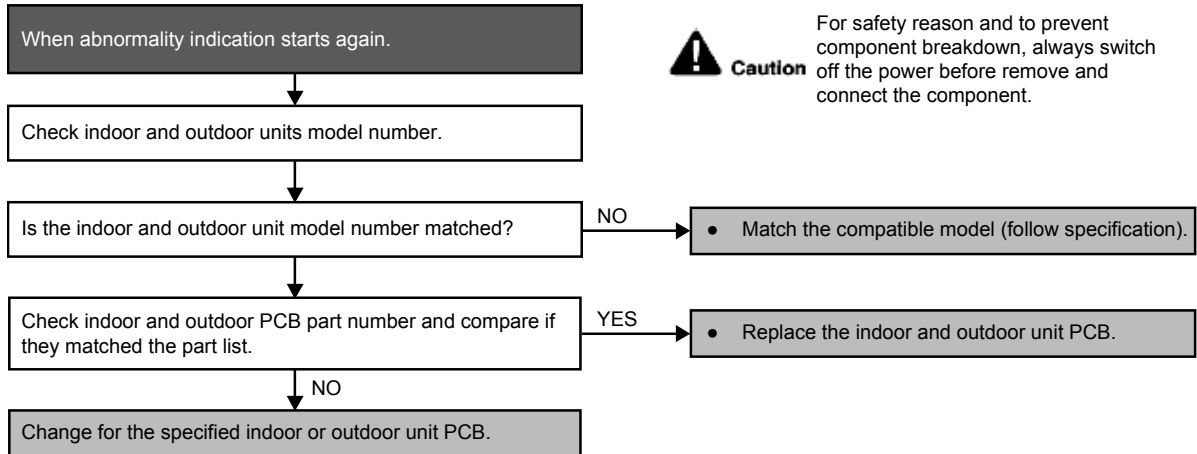

17.4.13 H36 (Outdoor Gas Pipe Sensor Abnormality)

Malfunction Decision Conditions

- During startup and operation of cooling and heating, the temperatures detected by the outdoor gas pipe temperature sensor are used to determine sensor errors.

Malfunction Caused

- Faulty connector connection.
- Faulty sensor.
- Faulty PCB.

Troubleshooting

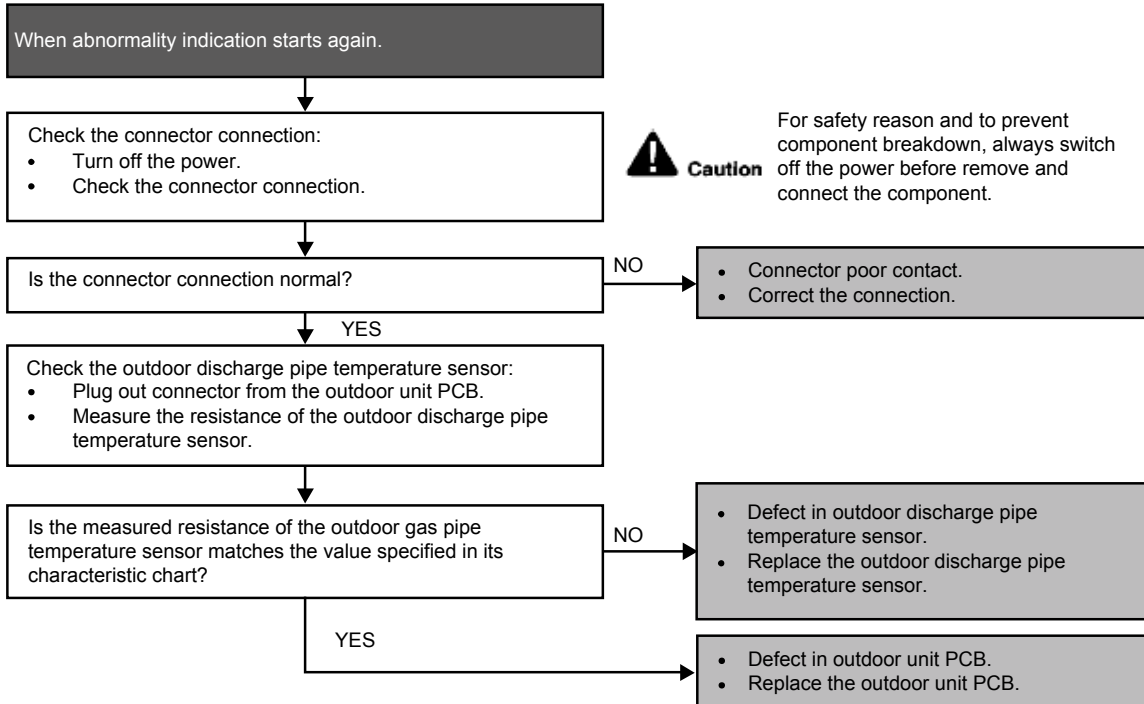

17.4.14 H37 (Outdoor Liquid Pipe Temperature Sensor Abnormality)

Malfunction Decision Conditions

- During startup and operation of cooling and heating, the temperatures detected by the outdoor liquid pipe temperature sensor are used to determine sensor errors.

Malfunction Caused

- Faulty connector connection.
- Faulty sensor.
- Faulty PCB.

Troubleshooting

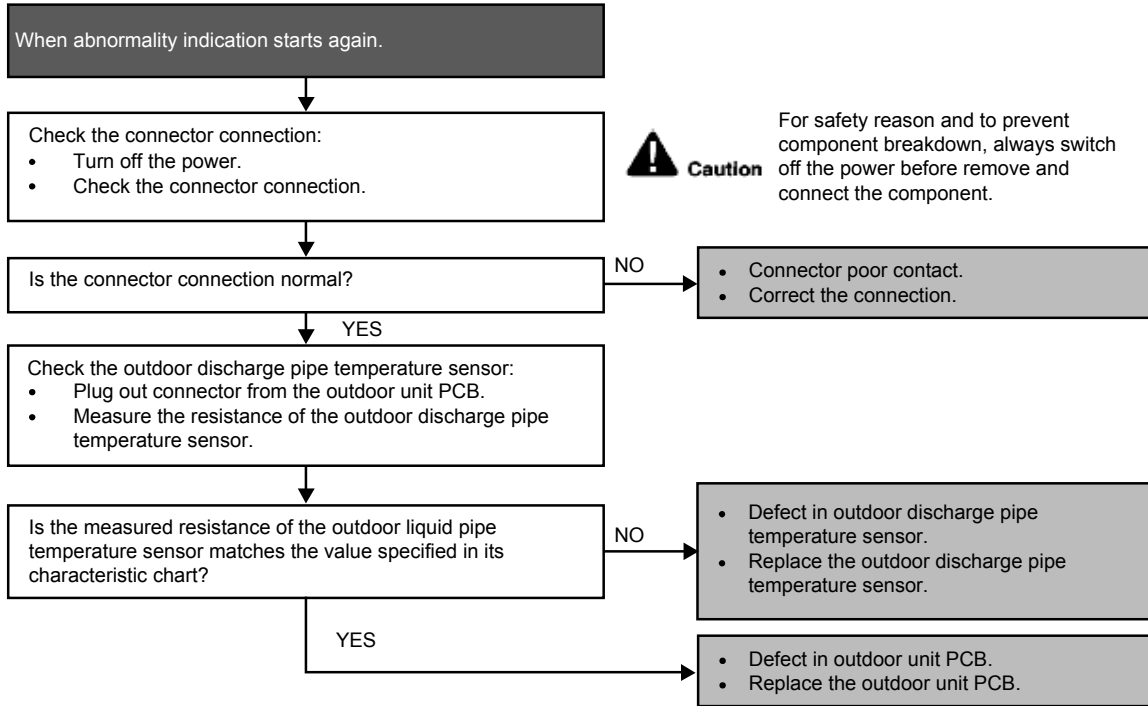

17.4.15 H59 (Human Activity Sensor Abnormality)

Malfunction Decision Conditions

- Feedback signal of human activity sensor.

Malfunction Caused

- Feedback signal is fixed at 0 VDC or 5 VDC continuously for 25 seconds during ECONAVI or AUTO COMFORT operation.
- Feedback signal is detected during ECONAVI or AUTO COMFORT off.

Troubleshooting

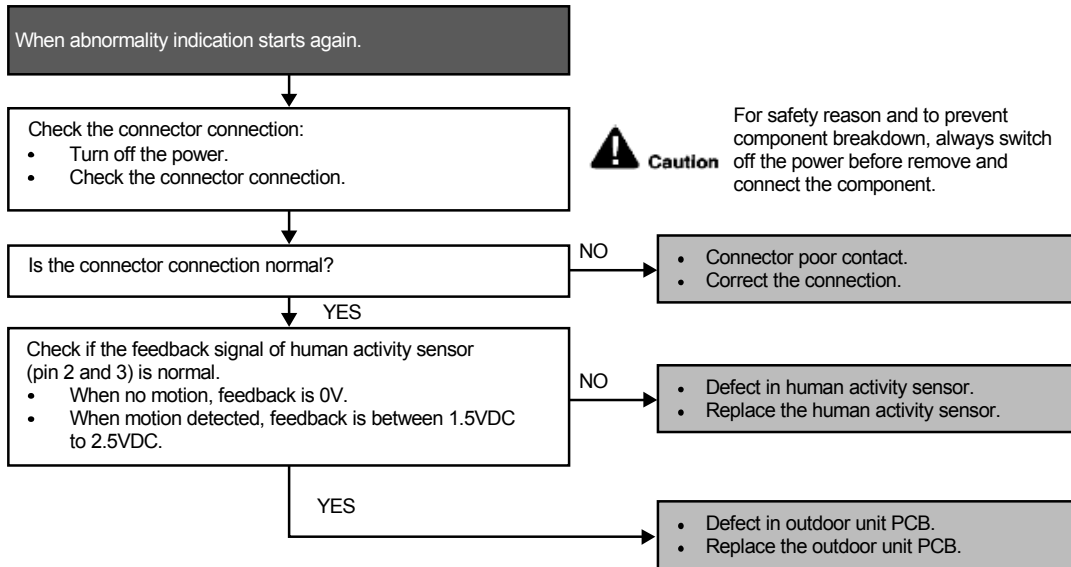

17.4.16 H70 (Light Sensor Abnormality)

Malfunction Decision Conditions

- Feedback signal of light sensor.

Malfunction Caused

- Feedback value is 0 VDC continuously.

Troubleshooting

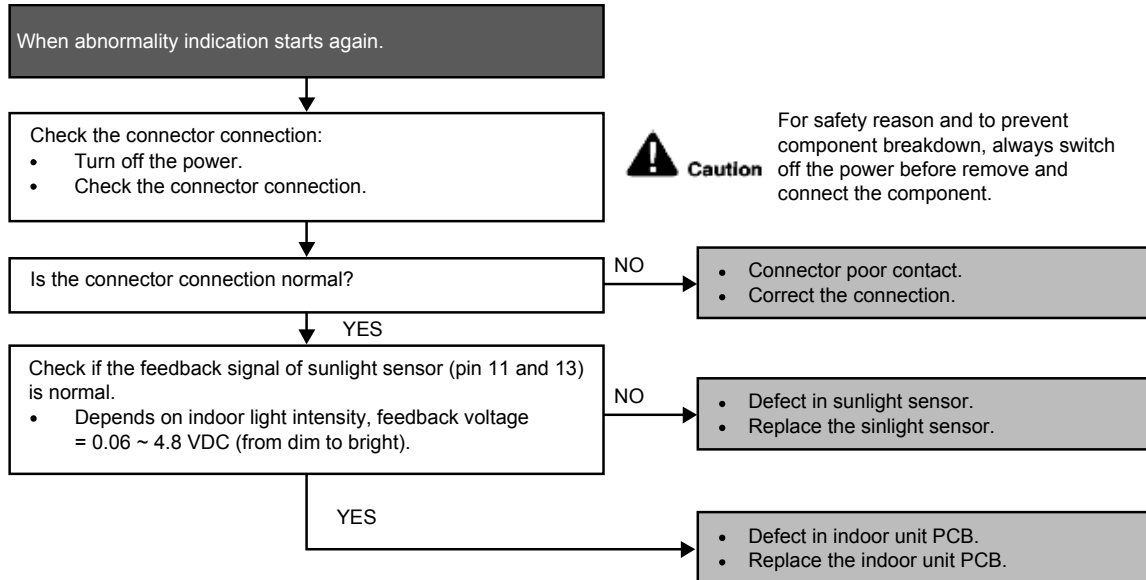

17.4.17 H97 (Outdoor Fan Motor – DC Motor Mechanism Locked) RE9SKUA/RE12SKUA

Malfunction Decision Conditions

- The rotation speed detected by the Hall IC during fan motor operation is used to determine abnormal fan motor.

Malfunction Caused

- Operation stops due to short circuit inside the fan motor winding.
- Operation stops due to breaking of wire inside the fan motor.
- Operation stops due to breaking of fan motor lead wires.
- Operation stops due to Hall IC malfunction.
- Operation error due to faulty outdoor unit PCB.

Troubleshooting

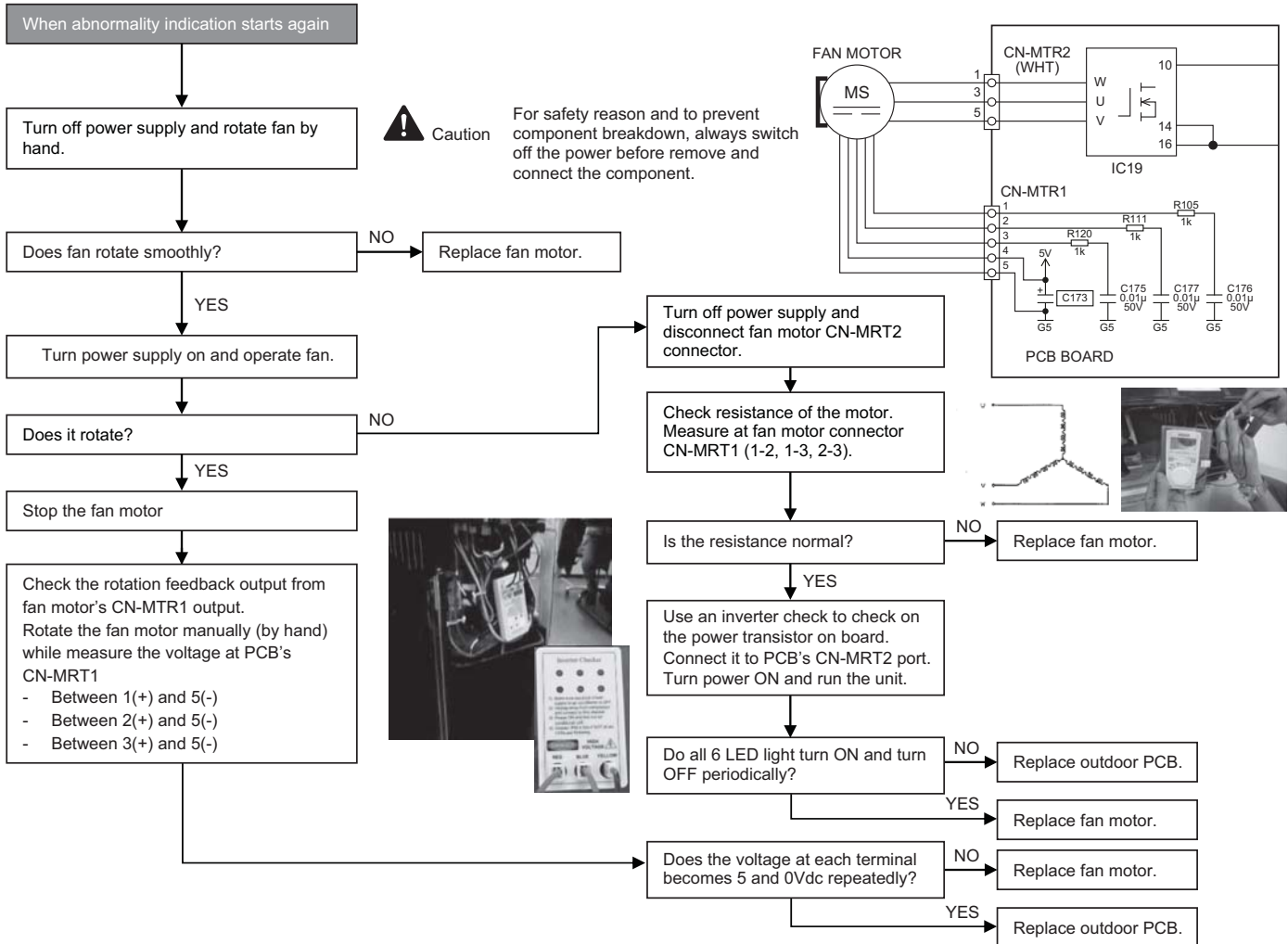

17.4.18 H97 (Outdoor Fan Motor – DC Motor Mechanism Locked) RE18SKUA/CU-RE24SKUA

Malfunction Decision Conditions

- The rotation speed detected by the Hall IC during fan motor operation is used to determine abnormal fan motor.

Malfunction Caused

- Operation stops due to short circuit inside the fan motor winding.
- Operation stops due to breaking of wire inside the fan motor.
- Operation stops due to breaking of fan motor lead wires.
- Operation stops due to Hall IC malfunction.
- Operation error due to faulty outdoor unit PCB.

Troubleshooting

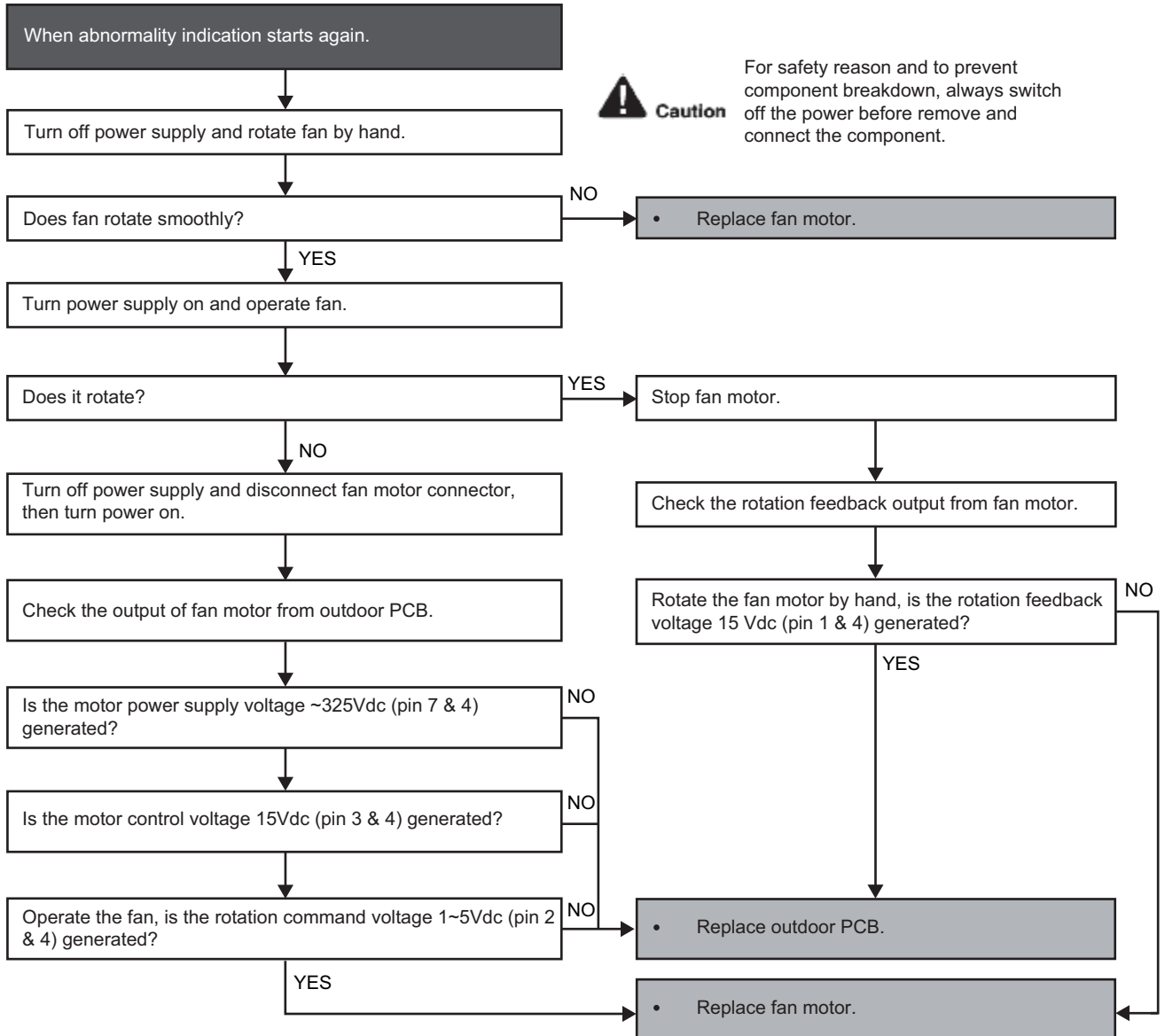

17.4.19 H98 (Error Code Stored in Memory and no alarm is triggered / no TIMER LED flashing)

Malfunction Decision Conditions

- Indoor high pressure is detected when indoor heat exchanger is detecting very high temperature when the unit is operating in heating operation.
- Phenomena: unit is stopping and re-starting very often in heating mode.

Malfunction Caused

- Indoor heat exchanger thermistor.
- Clogged air filter or heat exchanger.
- Over-bent pipe (liquid side).

Troubleshooting

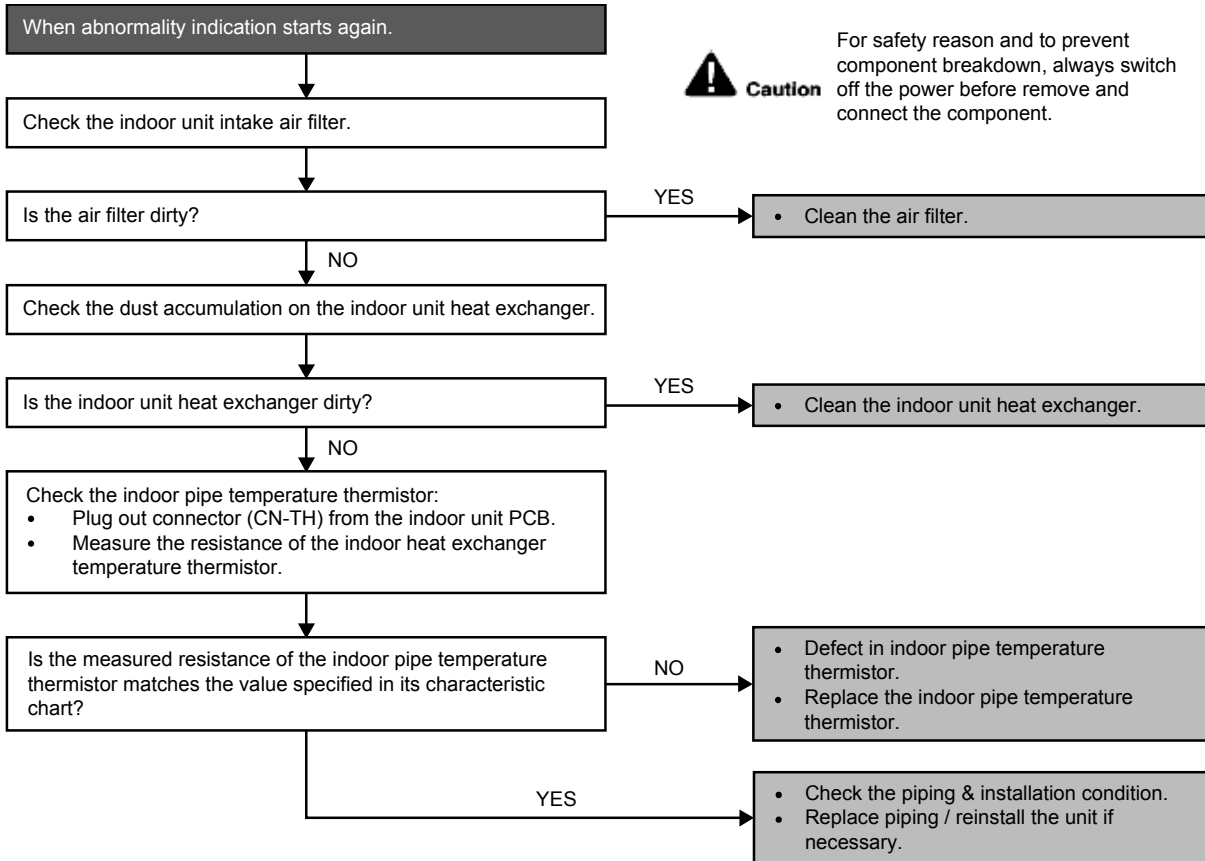

17.4.20 H99 (Indoor Freeze Prevention Protection: Cooling or Soft Dry)

Error Code will not display (no Timer LED blinking) but store in EEPROM

Malfunction Decision Conditions

- Freeze prevention control takes place (when indoor pipe temperature is lower than 2°C).

Malfunction Caused

- Air short circuit at indoor unit.
- Clogged indoor unit air filter.
- Dust accumulation on the indoor unit heat exchanger.
- 2/3 way valve closed.
- Faulty indoor unit fan motor.
- Refrigerant shortage (refrigerant leakage).
- Clogged expansion valve or strainer.
- Faulty indoor pipe temperature sensor.
- Faulty indoor unit PCB.

Troubleshooting

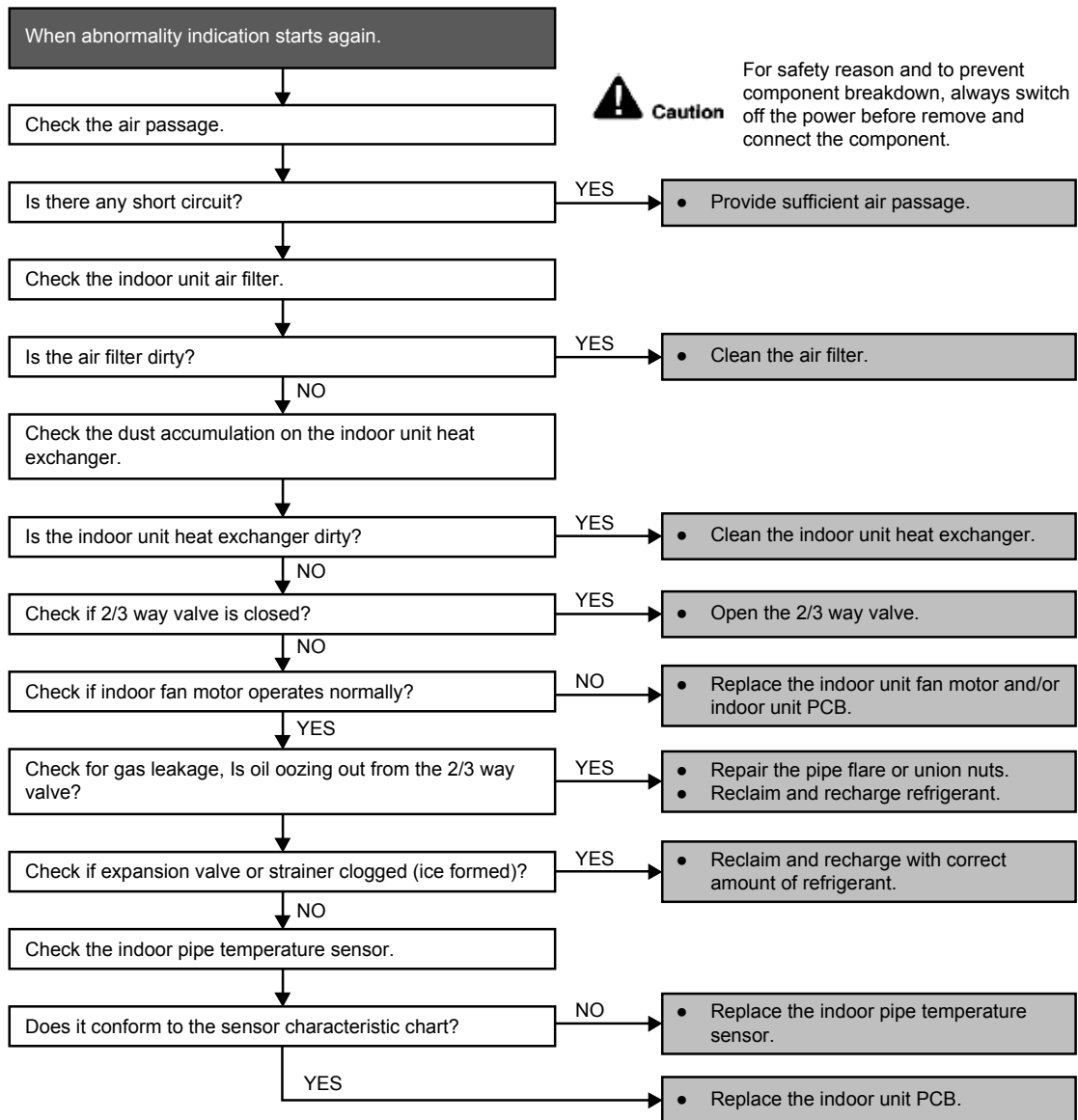

17.4.21 F11 (4-way Valve Switching Failure)

Malfunction Decision Conditions

- When indoor heat exchanger is cold during heating (except deice) or when indoor heat exchanger is hot during cooling and compressor operating, the 4-way valve is detected as malfunction.

Malfunction Caused

- Indoor heat exchanger (pipe) thermistor
- 4-way valve malfunction

Troubleshooting

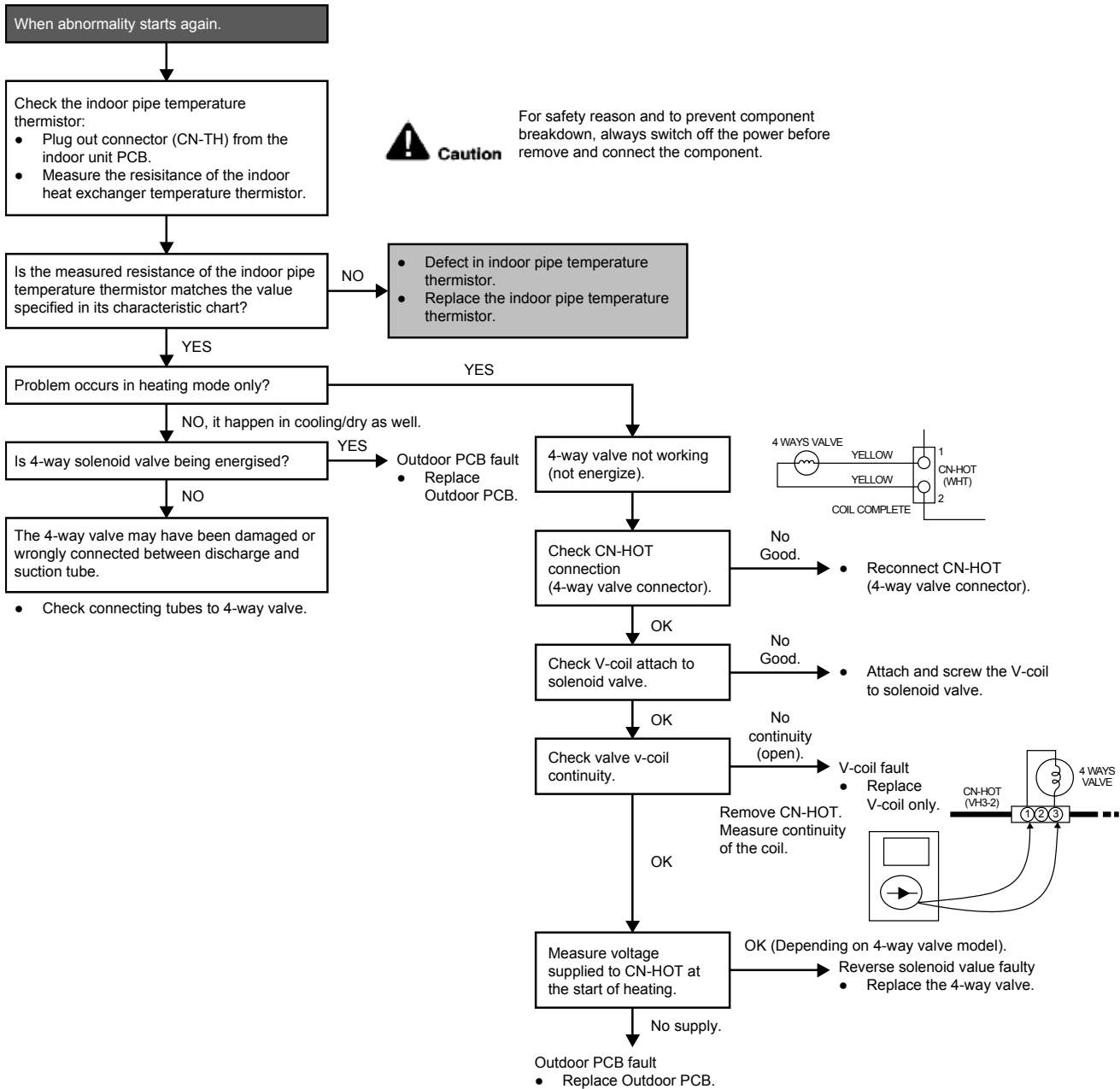

* Check gas side pipe – for hot gas flow in cooling mode

17.4.22 F17 (Indoor Standby Units Freezing Abnormality)

Malfunction Decision Conditions

- When the different between indoor intake air temperature and indoor pipe temperature is above 50°F or indoor pipe temperature is below 30.2°F

Remark:

When the indoor standby unit is freezing, the outdoor unit transfers F17 error code to the corresponding indoor unit and H39 to other indoor unit(s).

Malfunction Caused

- Wrong wiring connection
- Faulty sensor
- Faulty expansion valve

Troubleshooting

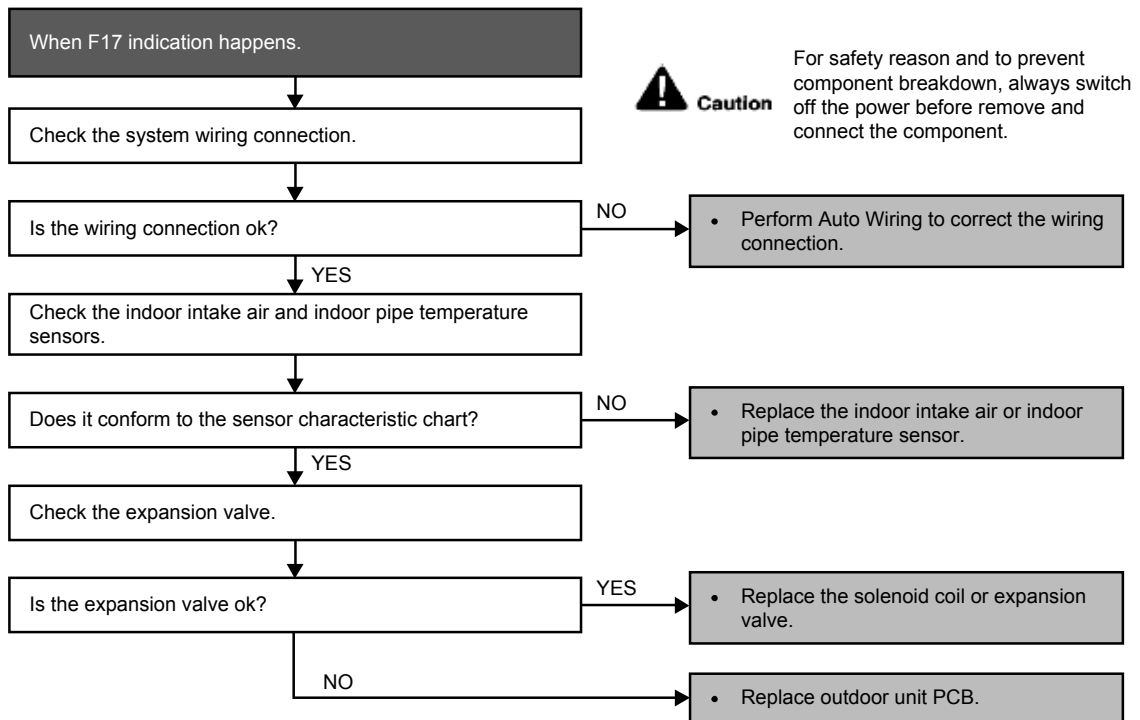

17.4.23 F90 (Power Factor Correction Protection)

Malfunction Decision Conditions

- To maintain DC voltage level supply to power transistor.
- To detect high DC voltage level after rectification.

Malfunction Caused

- During startup and operation of cooling and heating, when Power Factor Correction (PFC) protection circuitry at the outdoor unit main PCB senses abnormal DC voltage level for power transistors.
- When DC voltage detected is LOW, transistor switching will turn ON by controller to push-up the DC level.
- When DC voltage detected is HIGH (391Vdc – 425Vdc), active LOW signal will send by the controller to turn OFF relay RY-C.

Troubleshooting

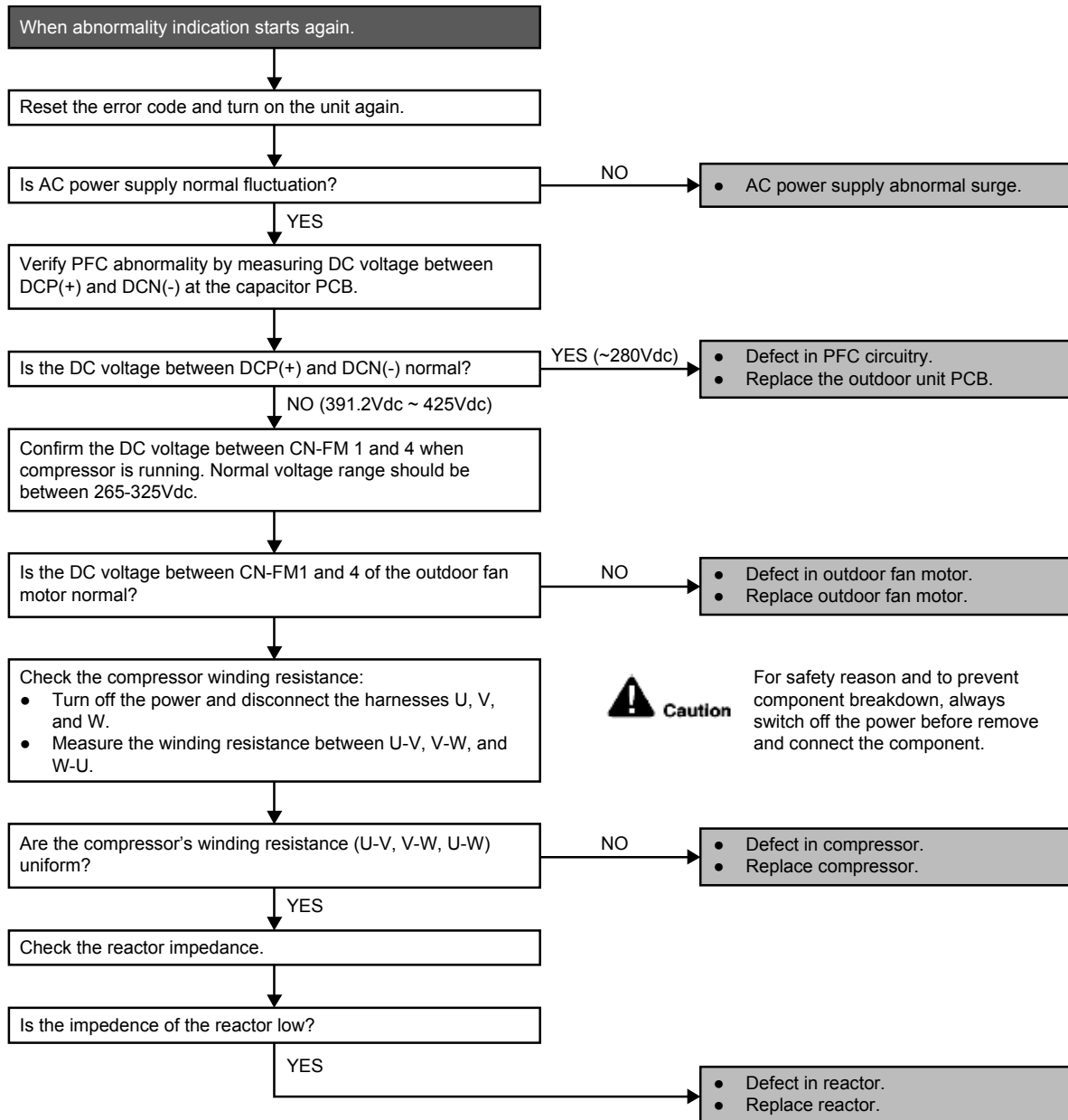

17.4.24 F91 (Refrigeration Cycle Abnormality)

Malfunction Decision Conditions

- The input current is low while the compressor is running at higher than the setting frequency.

Malfunction Caused

- Lack of gas.
- 3-way valve close.

Troubleshooting

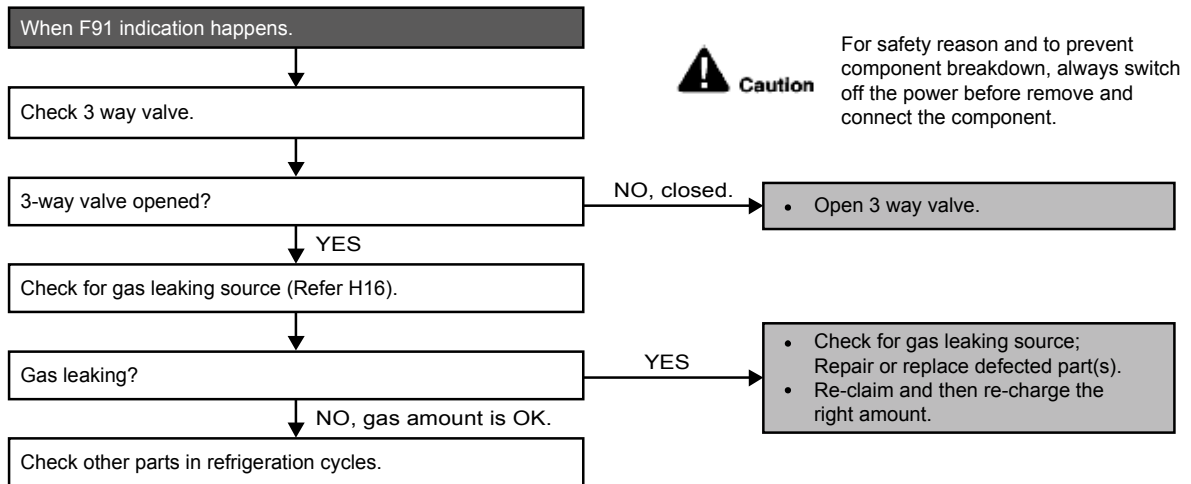

17.4.25 F93 (Compressor Rotation Failure)

Malfunction Decision Conditions

- A compressor rotation failure is detected by checking the compressor running condition through the position detection circuit.

Malfunction Caused

- Compressor terminal disconnect.
- Faulty Outdoor PCB.
- Faulty compressor.

Troubleshooting

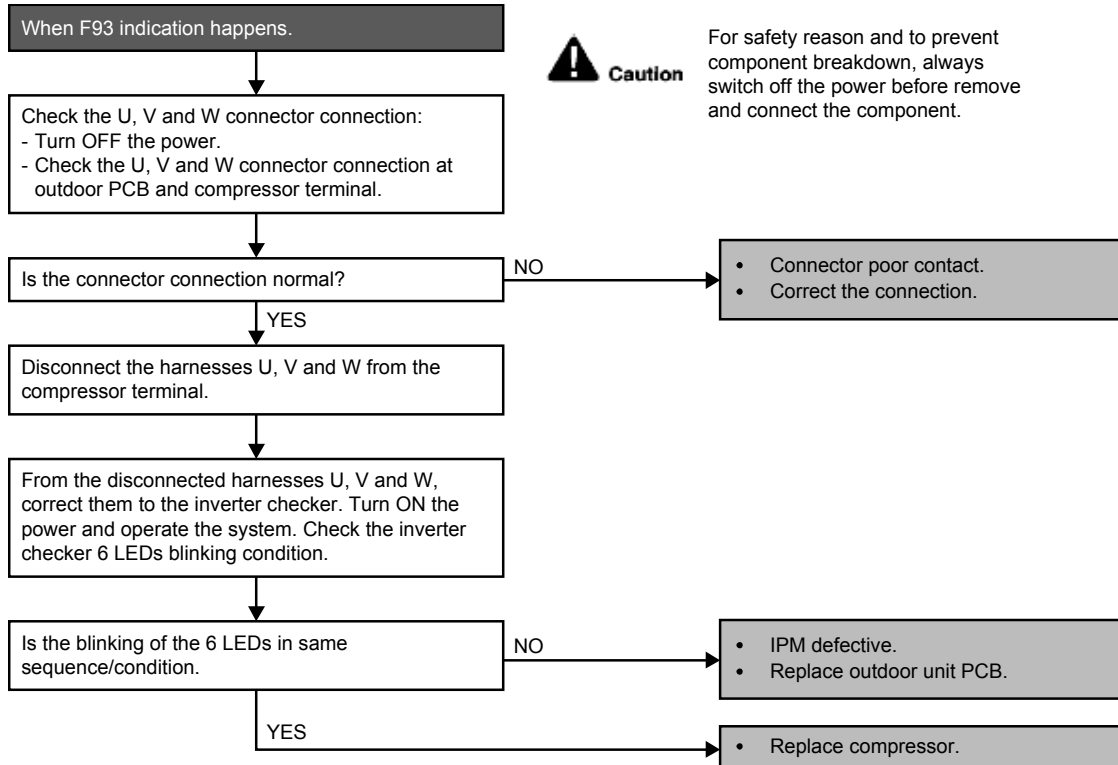

17.4.26 F95 (Outdoor High Pressure Protection: Cooling or Soft Dry)

Malfunction Decision Conditions

- During operation of cooling or soft dry, when outdoor unit heat exchanger high temperature data is detected by the outdoor unit heat exchanger thermistor.

Malfunction Caused

- Outdoor heat exchanger temperature rise due to short-circuit of hot discharge air flow.
- Outdoor heat exchanger temperature rise due to defective of outdoor fan motor.
- Outdoor heat exchanger temperature rise due to defective outdoor heat exchanger thermistor.
- Outdoor heat exchanger temperature rise due to defective of outdoor unit PCB.

Troubleshooting

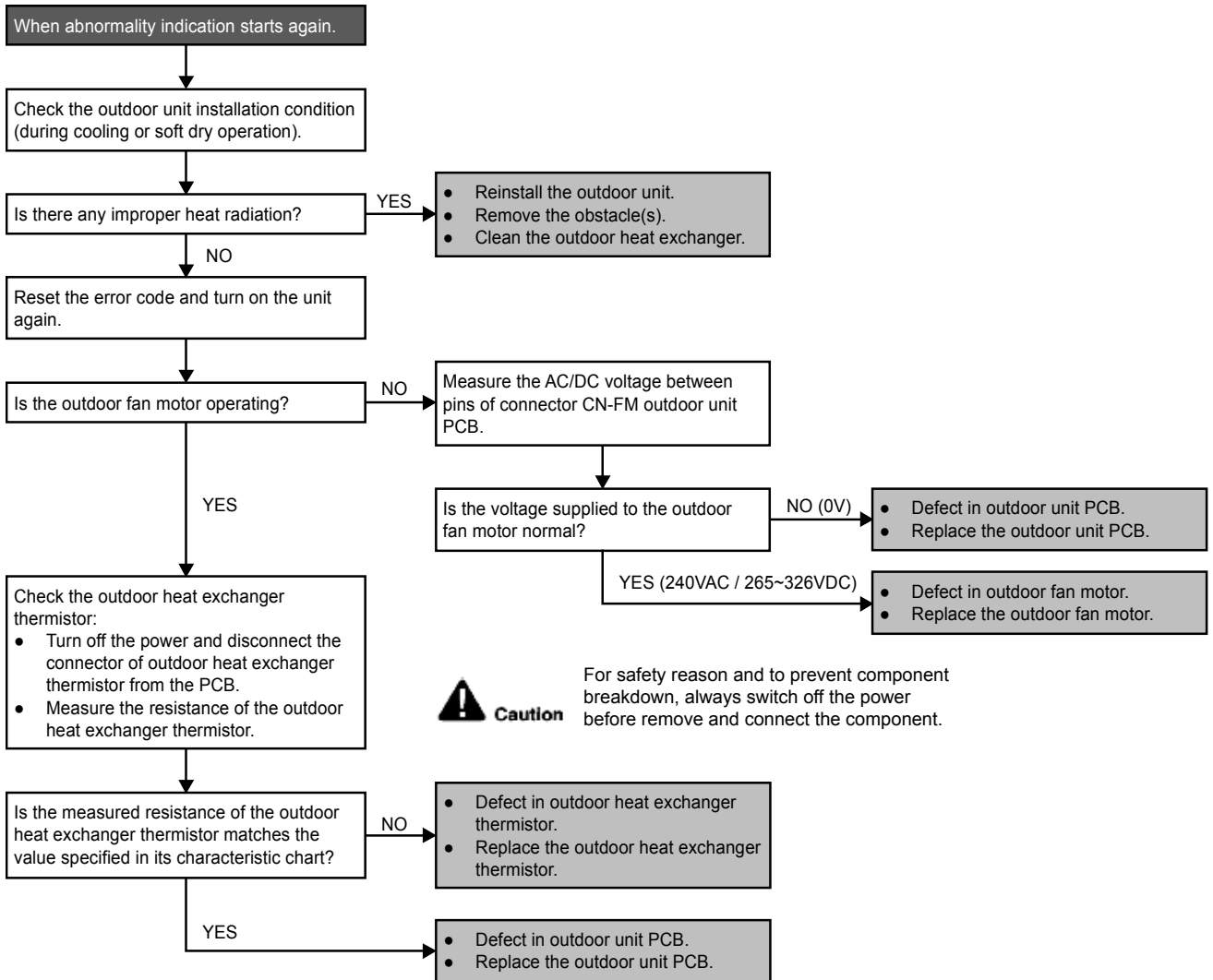

17.4.27 F96 (IPM Overheating)

Malfunction Decision Conditions

- During operating of cooling and heating, when IPM temperature data (212°F) is detected by the IPM temperature sensor.

Multi Models only

- Compressor Overheating: During operation of cooling and heating, when the compressor OL is activated.
- Heat Sink Overheating: During operation of cooling and heating, when heat sink temperature data (194°F) is detected by the heat sink temperature sensor.

Malfunction Caused

- IPM overheats due to short circuit of hot discharge air flow.
- IPM overheats due to defective of outdoor fan motor.
- IPM overheats due to defective of internal circuitry of IPM.
- IPM overheats due to defective IPM temperature sensor.

Multi Models Only

- Compressor OL connector poor contact.
- Compressor OL faulty.

Troubleshooting

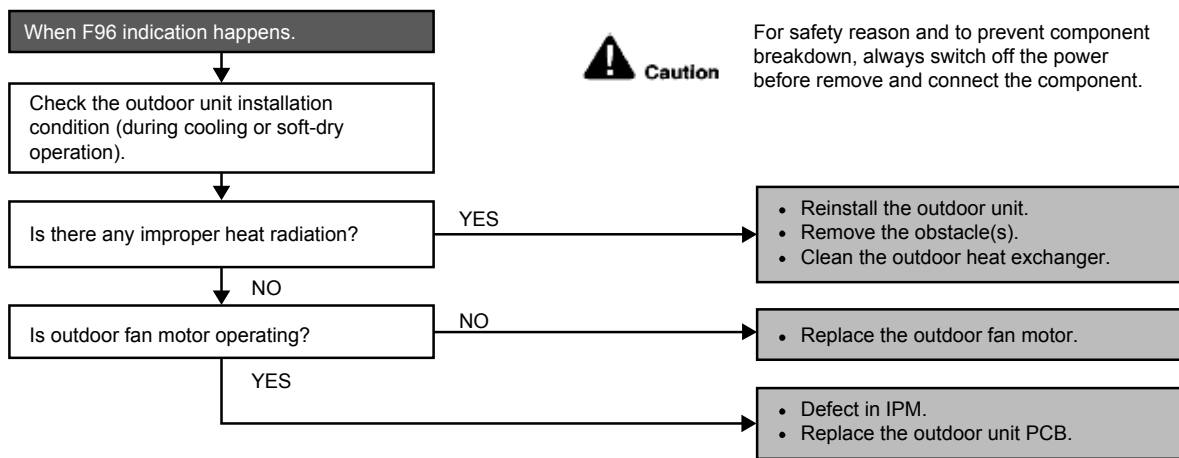

17.4.28 F97 (Compress or Overheating)

Malfunction Decision Conditions

- During operation of cooling and heating, when compressor tank temperature data (233.6°F) is detected by the compressor tank temperature sensor.

Malfunction Caused

- Faulty compressor tank temperature sensor
- 2/3 way valve closed
- Refrigerant shortage (refrigerant leakage)
- Faulty outdoor unit PCB
- Faulty compressor

Troubleshooting

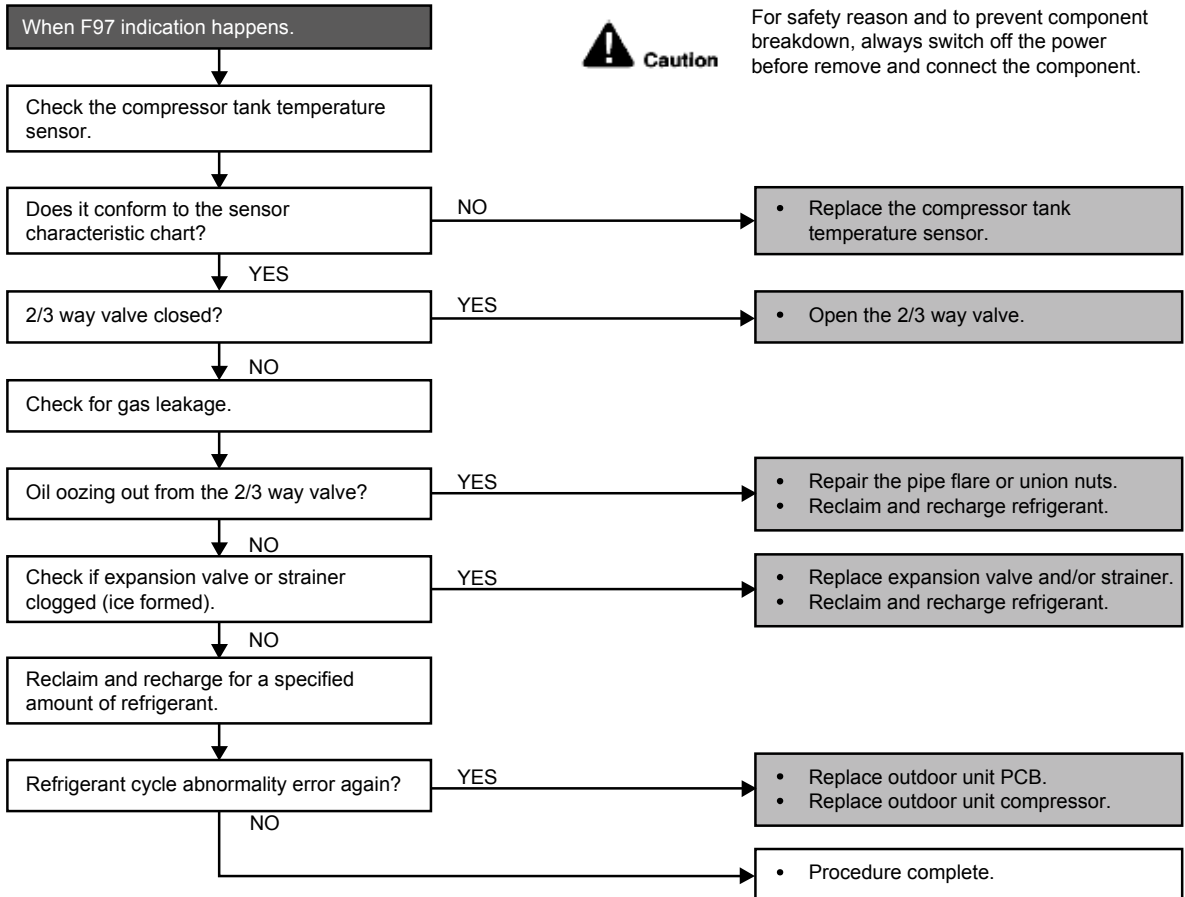

17.4.29 F98 (Input Over Current Detection)

Malfunction Decision Conditions

- During operation of cooling and heating, when an input over-current (X value in Total Running Current Control) is detected by checking the input current value being detected by current transformer (CT) with the compressor running.

Malfunction Caused

- Excessive refrigerant.
- Faulty outdoor unit PCB.

Troubleshooting

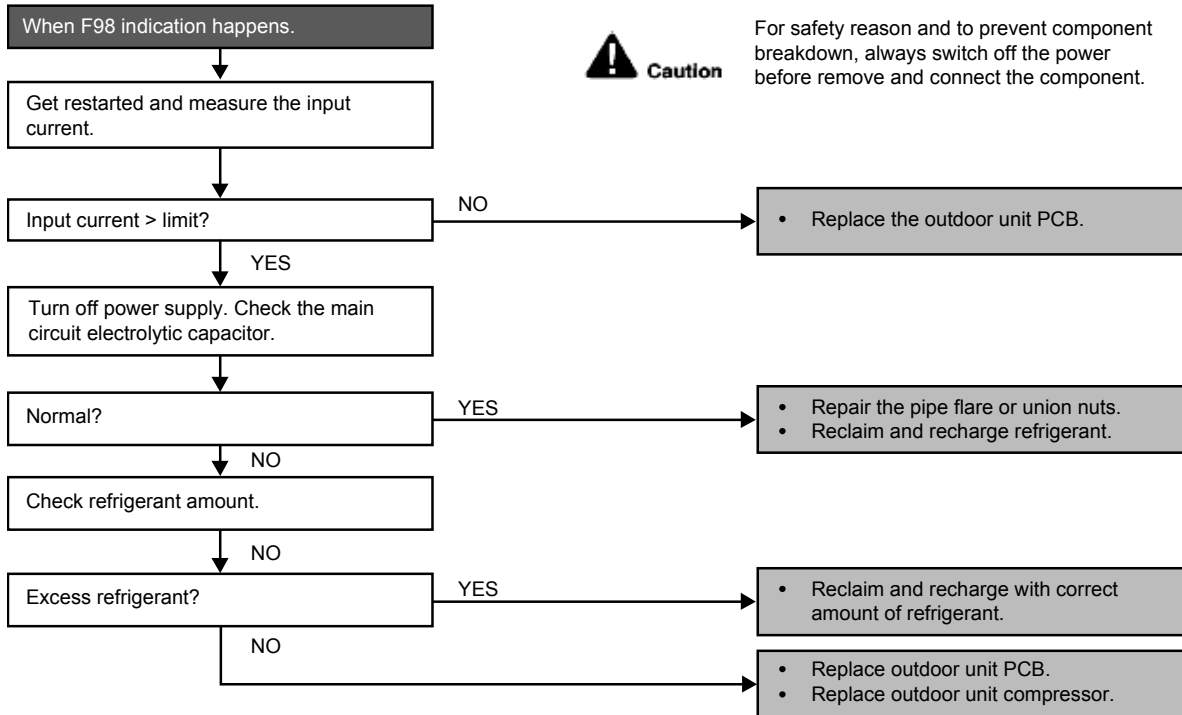

17.4.30 F99 (DC Peak Detection)

Malfunction Decision Conditions

During startup and operation of cooling and heating, when inverter DC peak data is received by the outdoor internal DC Peak sensing circuitry.

Malfunction Caused

- DC current peak due to compressor failure.
- DC current peak due to defective power transistor(s).
- DC current peak due to defective outdoor unit PCB.
- DC current peak due to short circuit.

Troubleshooting

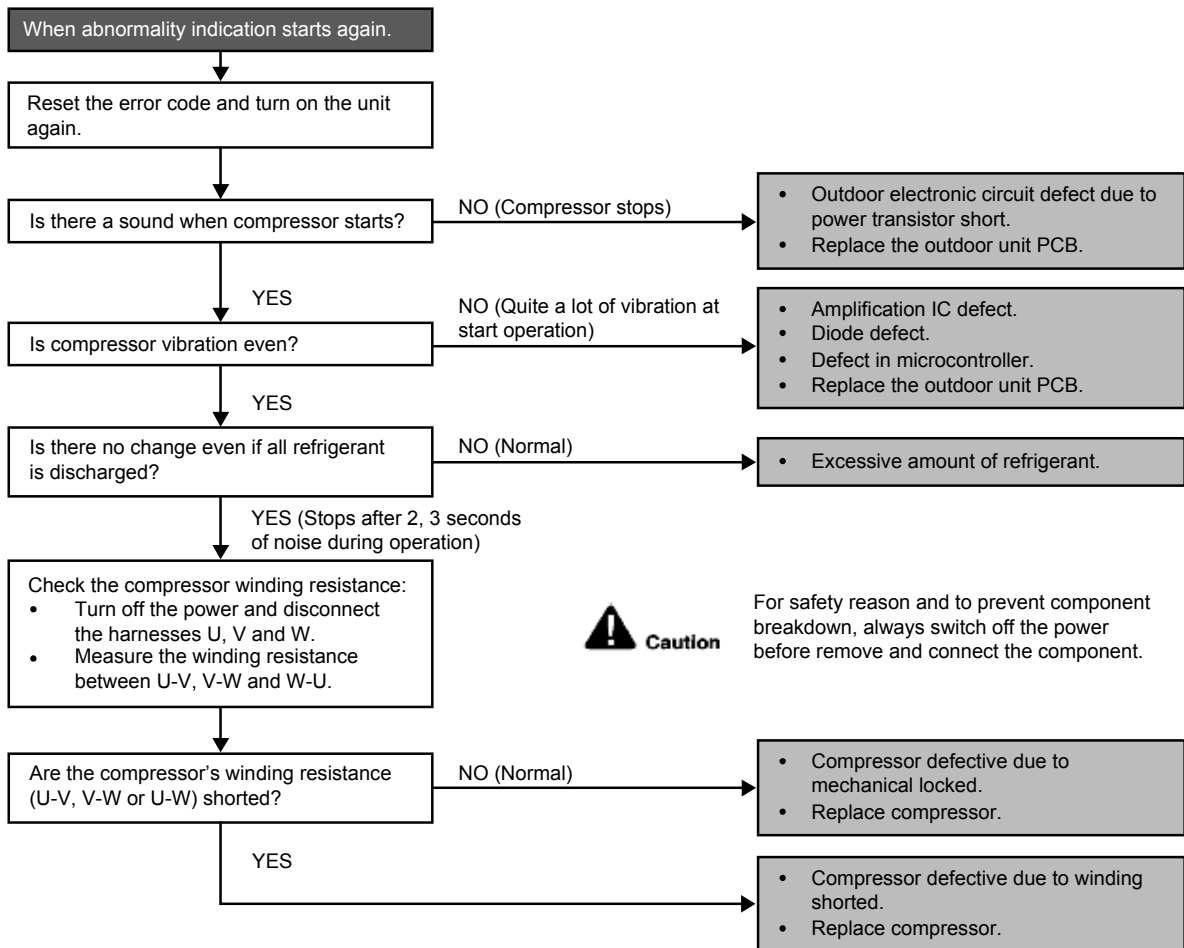

18. Disassembly and Assembly Instructions



High Voltage is generated in the electrical parts area by the capacitor. Ensure that the capacitor has discharged sufficiently before proceeding with repair work. Failure to heed this caution may result in electric shocks.

18.1 CS-RE9SKUA CS-RE12SKUA

18.1.1 Indoor Electronic Controllers, Cross Flow Fan and Indoor Fan Motor Removal Procedures

18.1.1.1 To Remove Front Grille

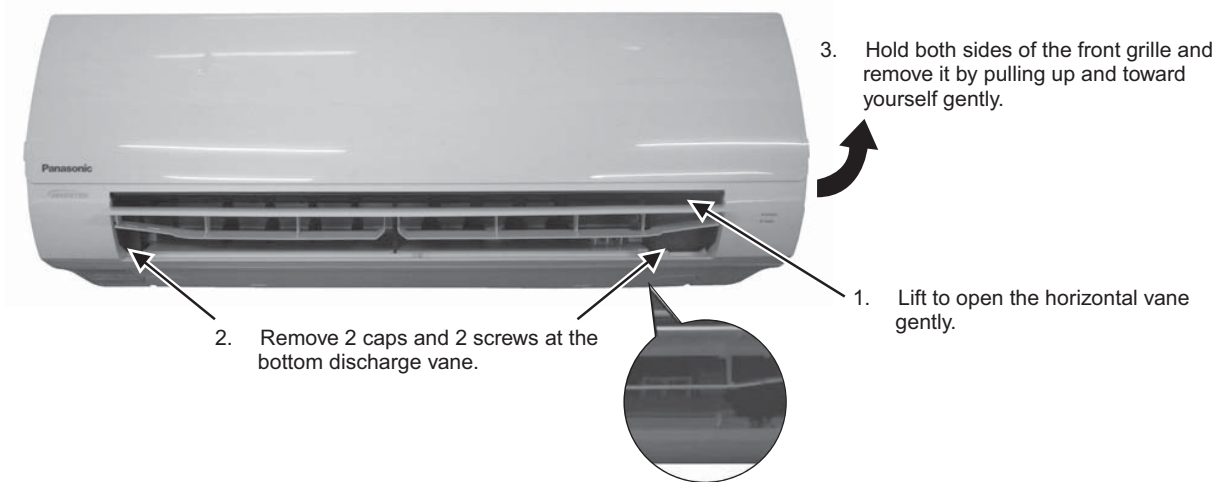

Figure 1

18.1.1.2 To Remove Horizontal Vane

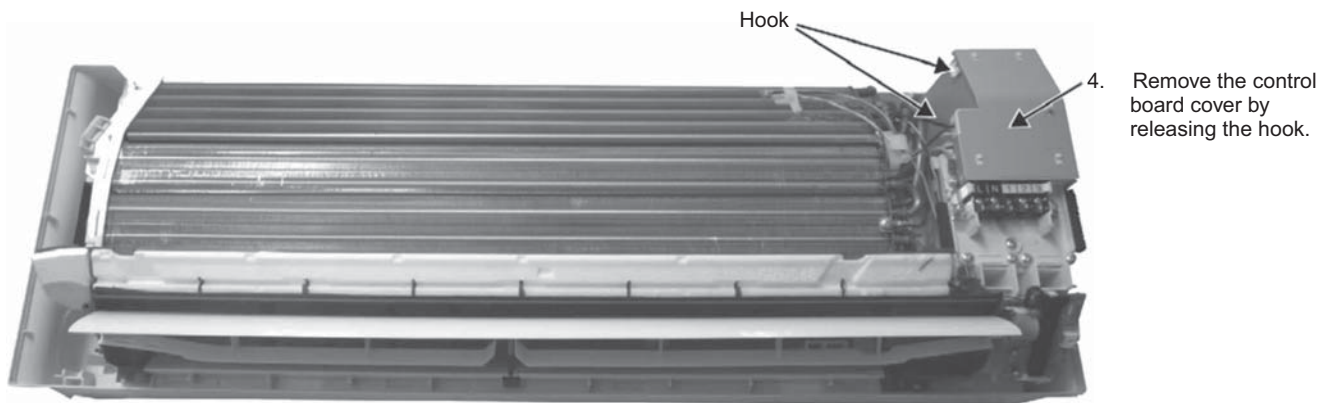

Figure 2

18.1.1.3 To Remove Power Electronic Controller

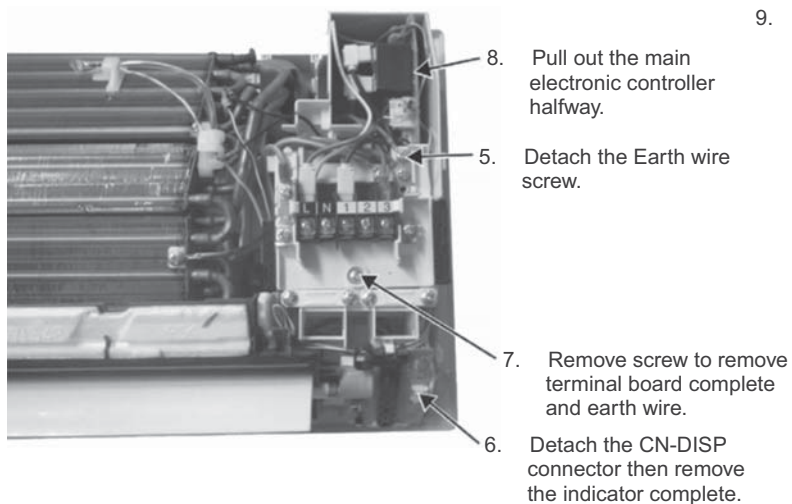

Figure 3

- Detach connectors as labeled from the electronic controller. Then pull out main controller gently.

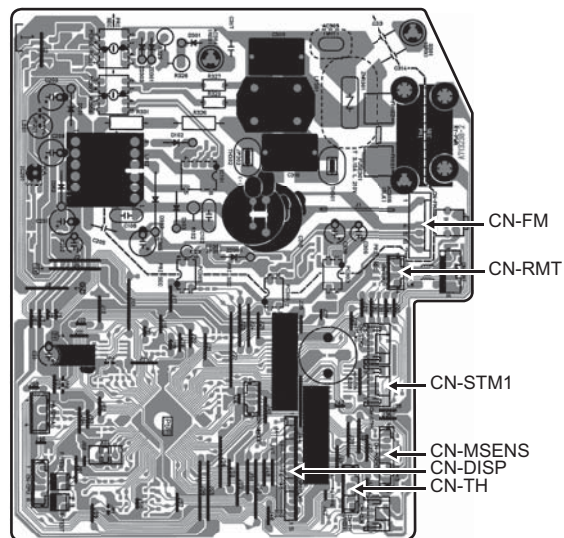

Figure 4

18.1.1.4 To Remove Discharge Grille



- Pull out to remove the drain hose from the discharge grille.
- Then pull out the discharge grille downward gently to dismantle it.

Figure 5

18.1.1.5 To Remove Control Board

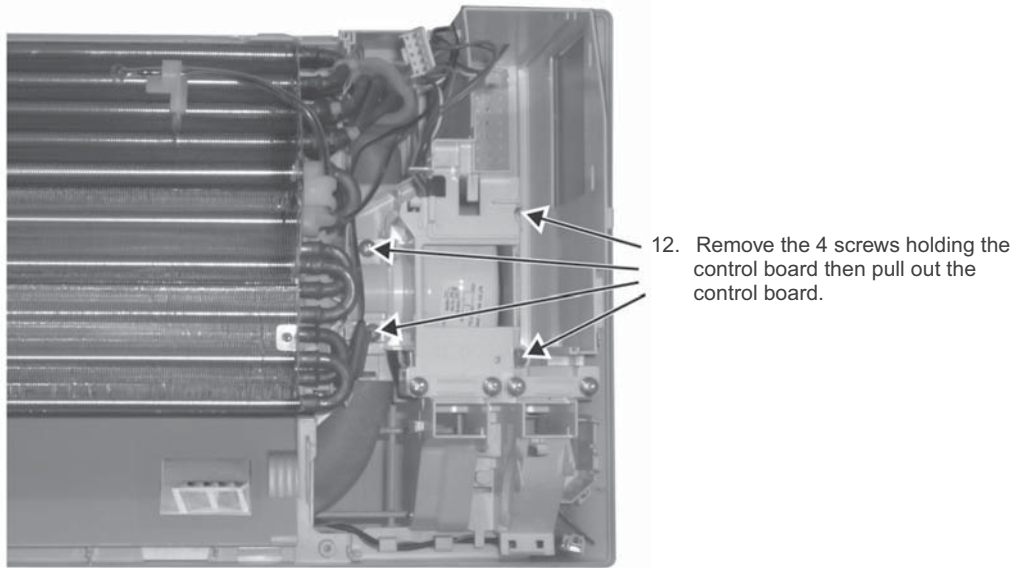

Figure 6

18.1.1.6 To Remove Cross Flow Fan and Indoor Fan Motor

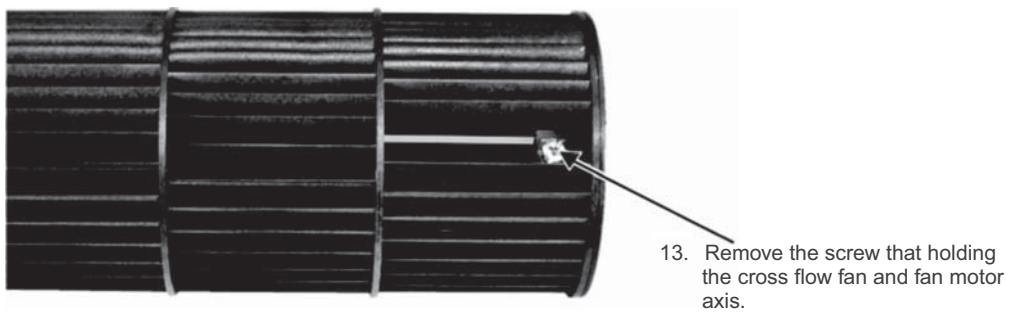

Figure 7

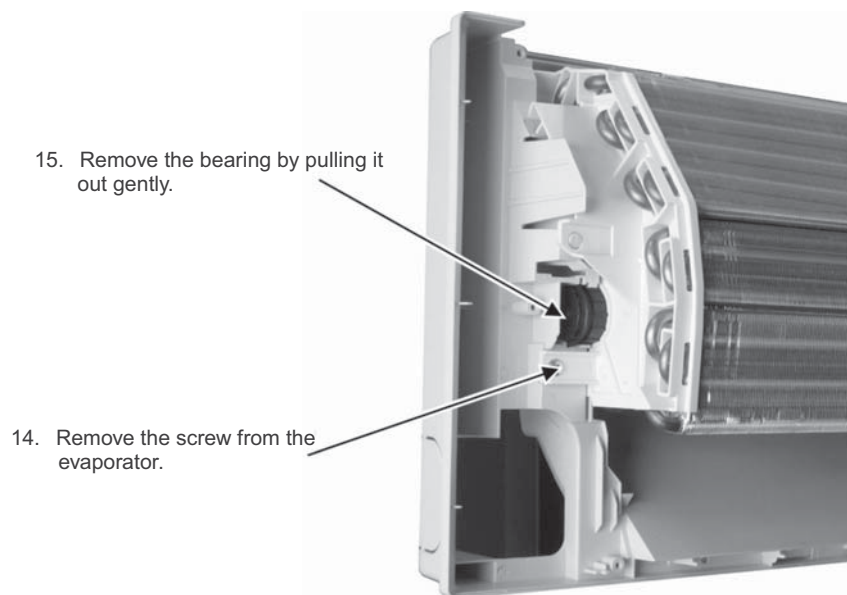

Figure 8

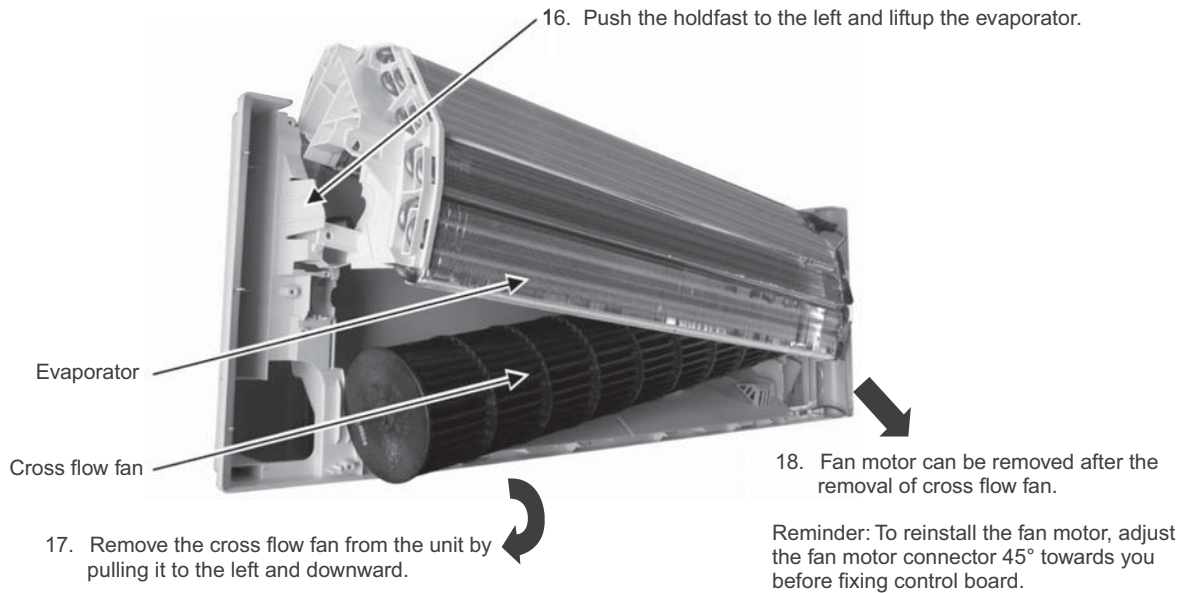

Figure 9

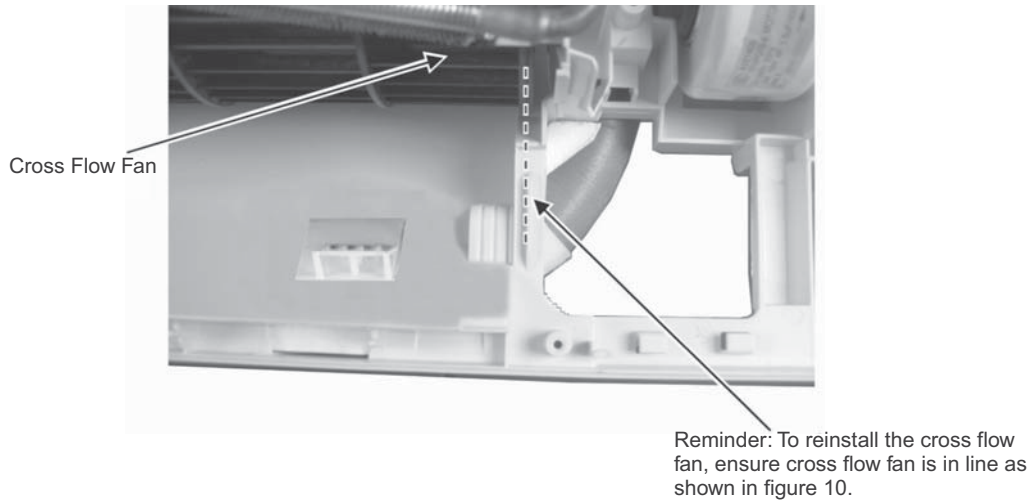

Figure 10

⚠ WARNING

High Voltage is generated in the electrical parts area by the capacitor. Ensure that the capacitor has discharged sufficiently before proceeding with repair work. Failure to heed this caution may result in electric shocks.

18.2 CS-RE18SKUA CS-RE24SKUA

18.2.1 Indoor Electronic Controllers, Cross Flow Fan and Indoor Fan Motor Removal Procedures

18.2.1.1 To Remove Front Grille

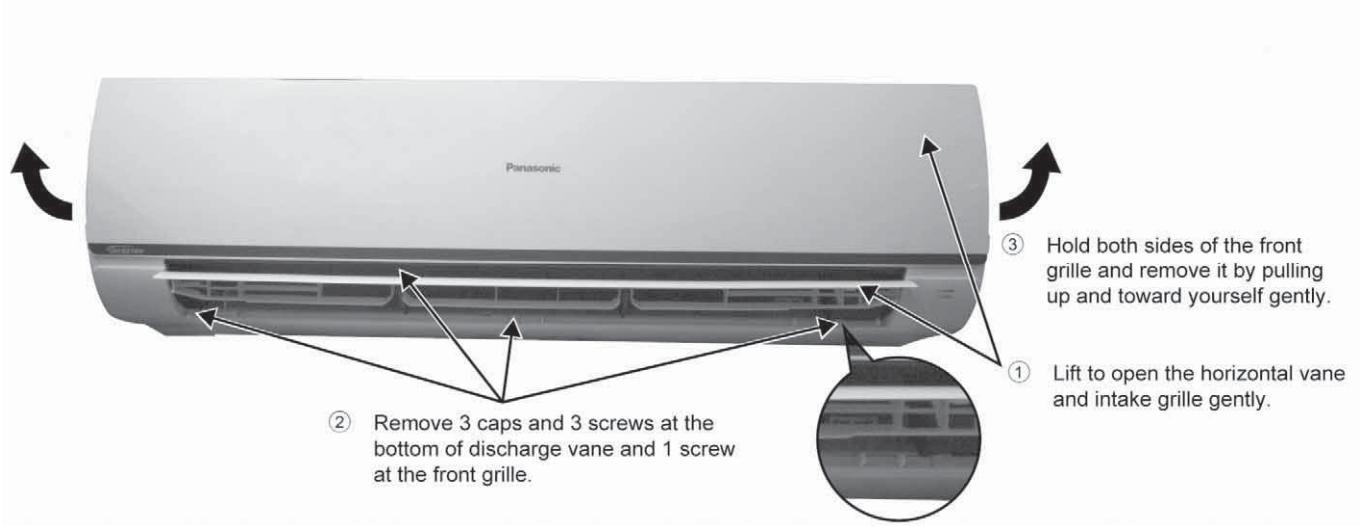

Figure 11

18.2.1.2 To Remove Electronic Controller

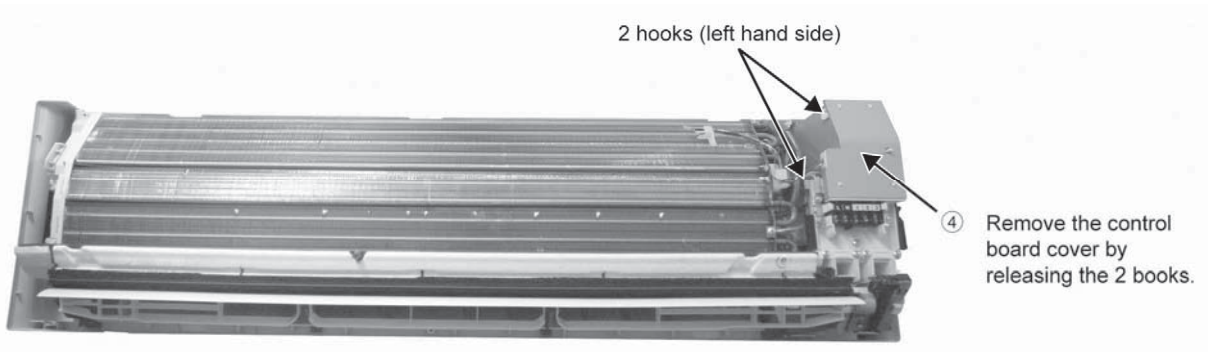

Figure 12

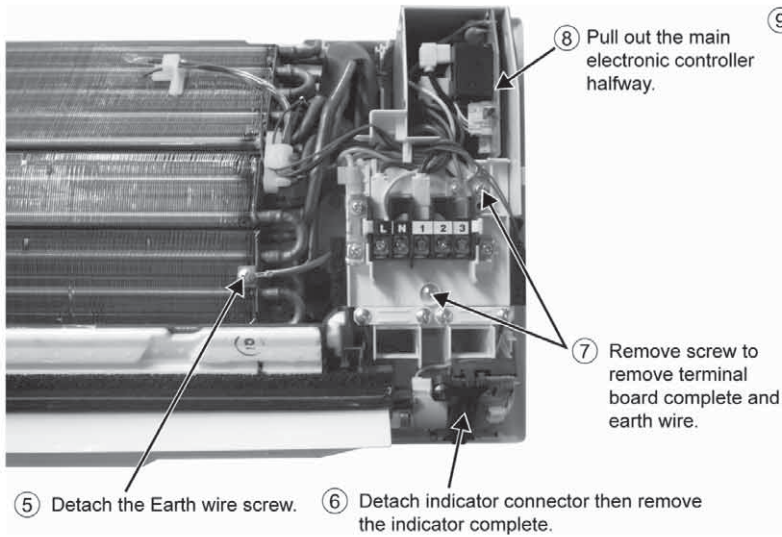

Figure 13

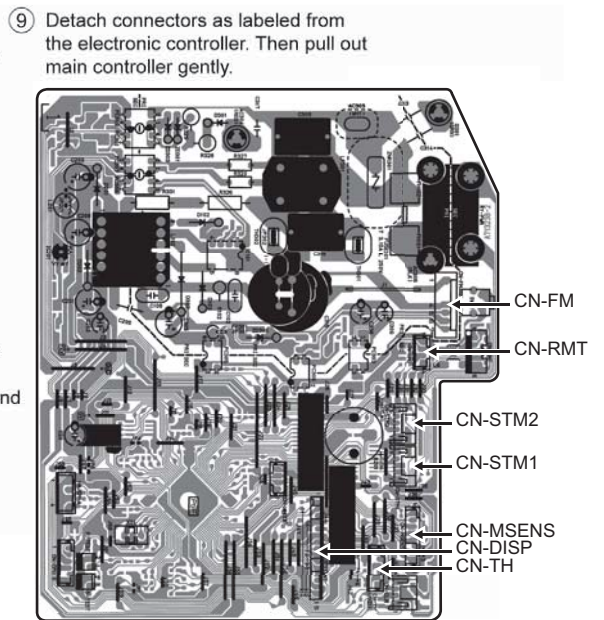

Figure 14

18.2.1.3 To Remove Discharge Grille

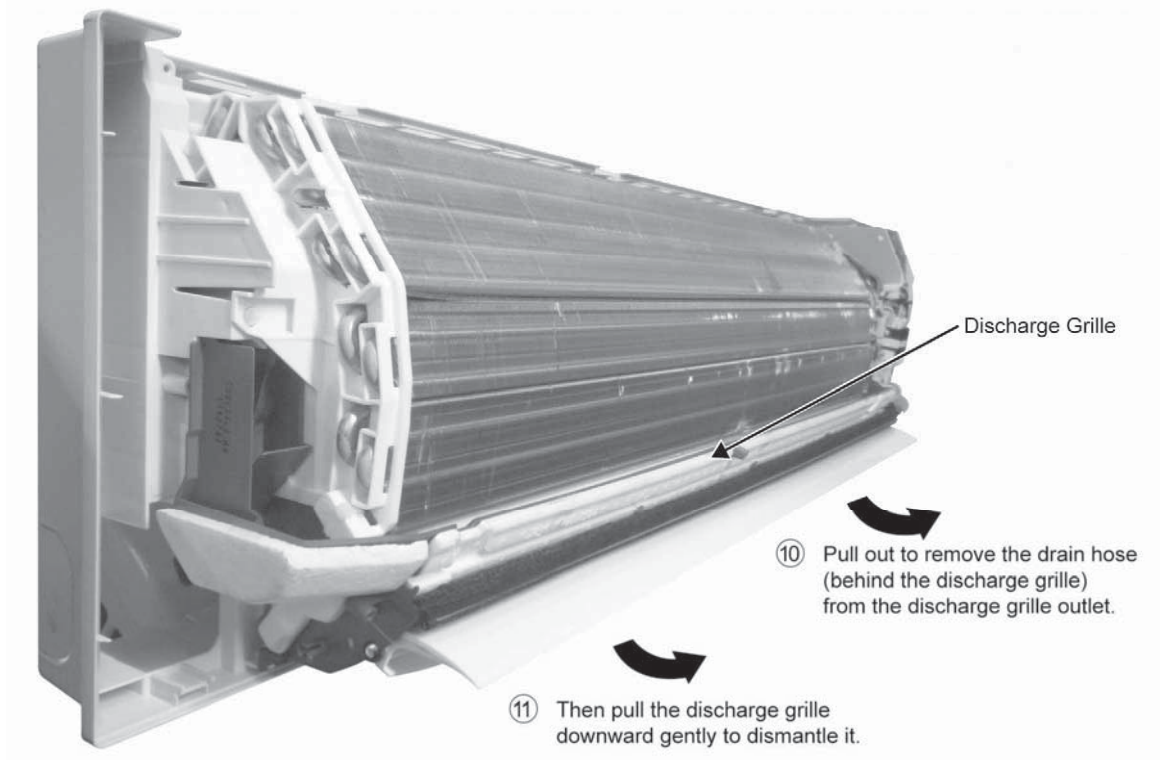

Figure 15

18.2.1.4 To Remove Control Board

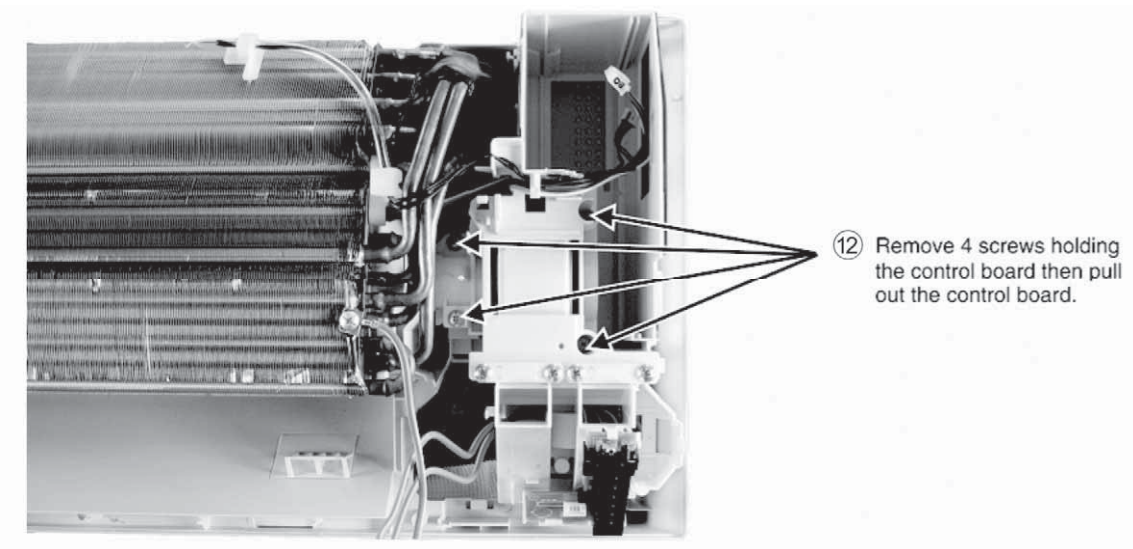

Figure 16

18.2.1.5 To Remove Cross Flow Fan and Indoor Fan Motor

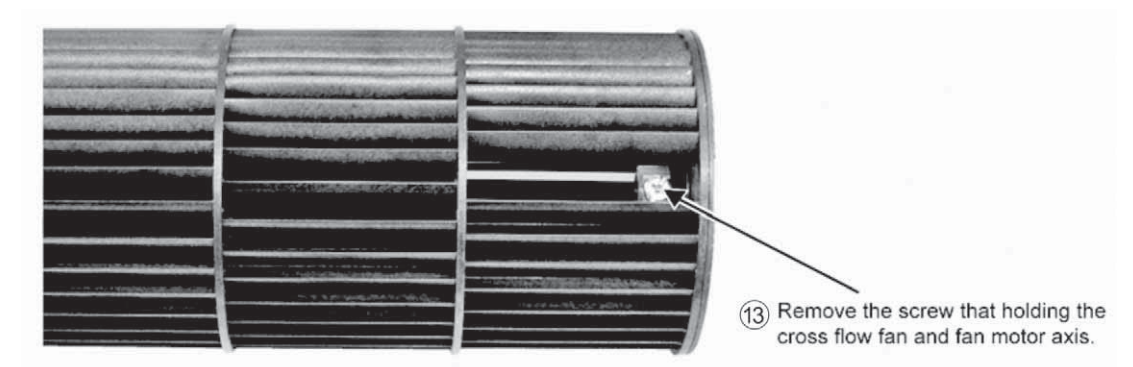

Figure 17

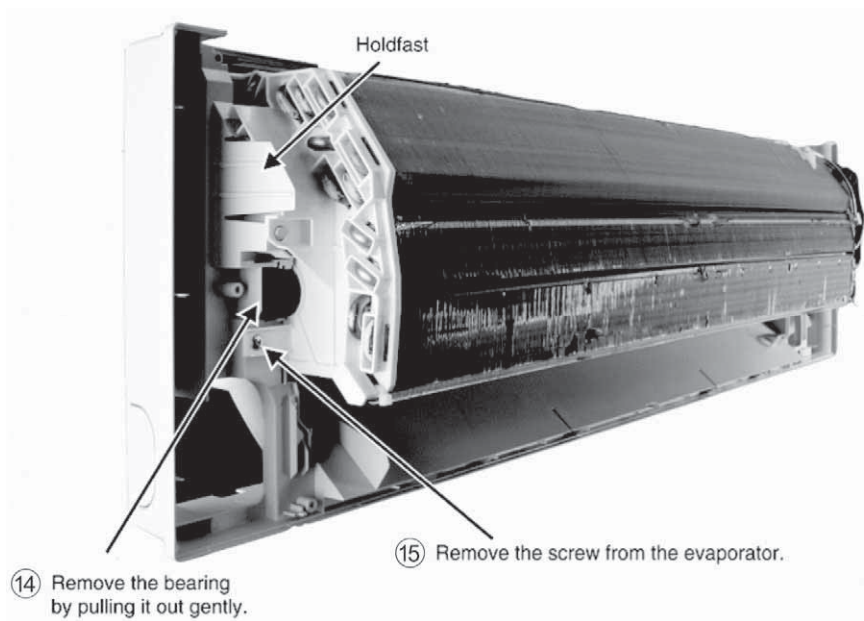

Figure 18

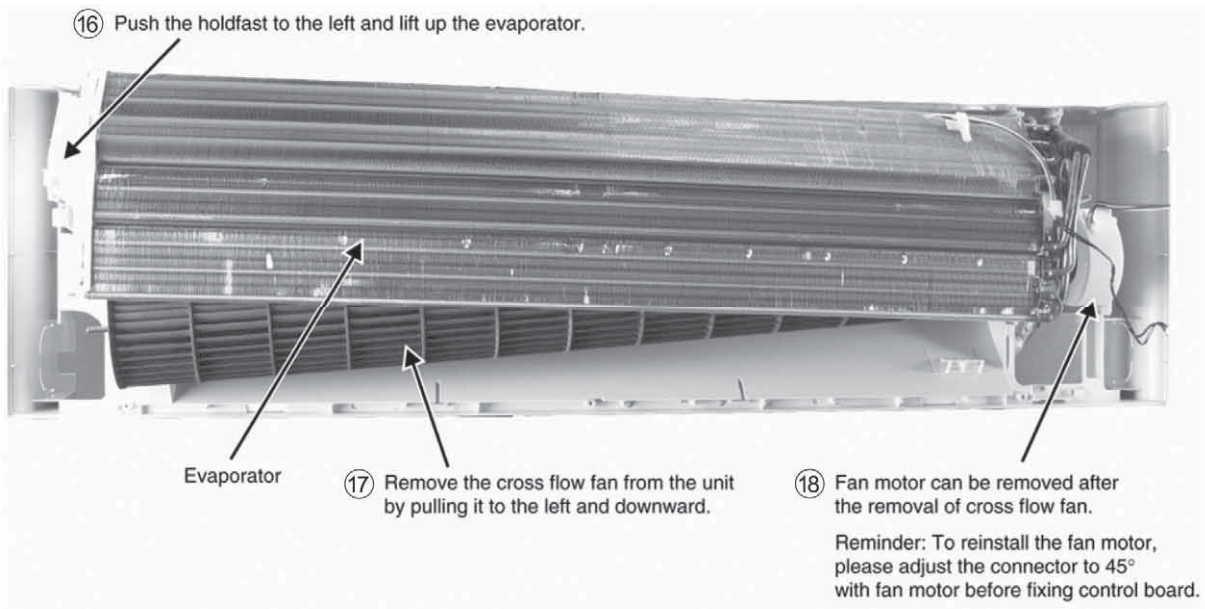

Figure 19

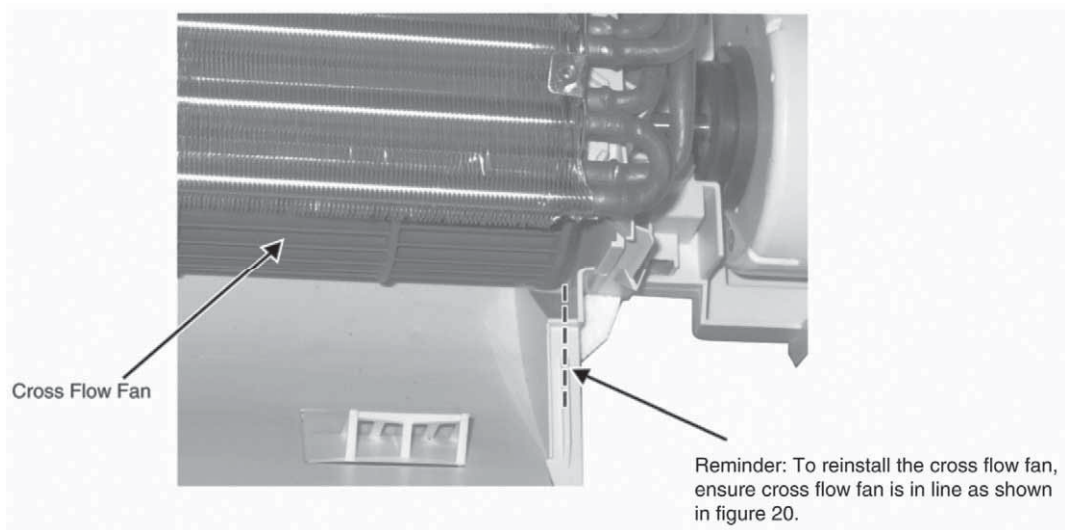

Figure 20

18.3 Outdoor Electronic Controller Removal Procedure

18.3.1 CU-RE9SKUA CU-RE12SKUA

⚠ Caution! When handling electronic controller, be careful of electrostatic discharge.

- 1 Remove the 3 screws of the Top Panel.

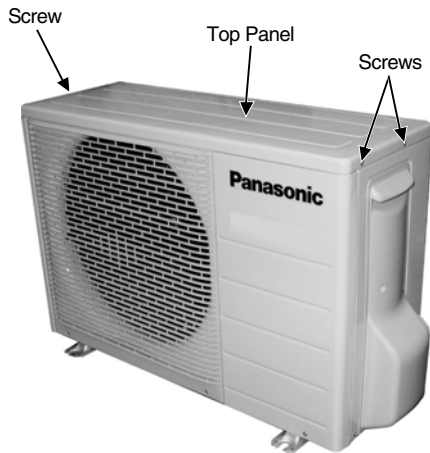

Fig. 1

- 2 Remove the 6 screws of the Front Panel.

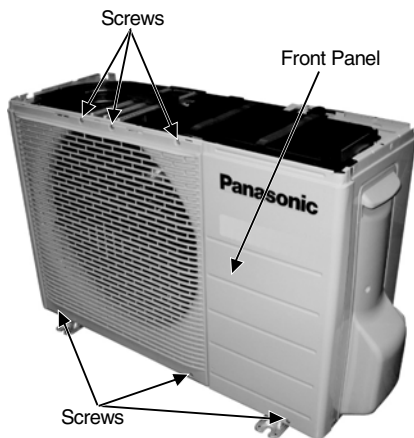

Fig. 2

- 3 Remove the screw of the Terminal Board Cover.

- 4 Remove the Top Cover of the Control Board by 4 hooks.

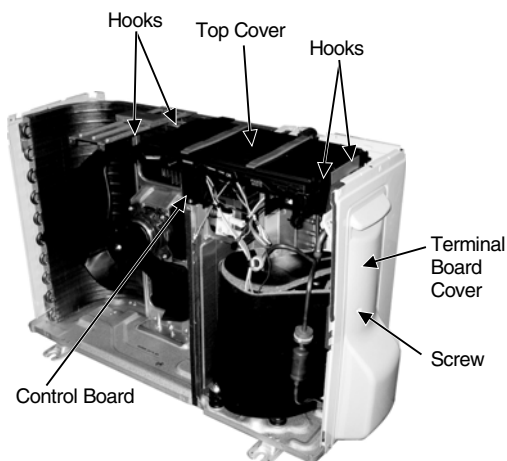

Fig. 3

- 5 Remove the Control Board as follows:

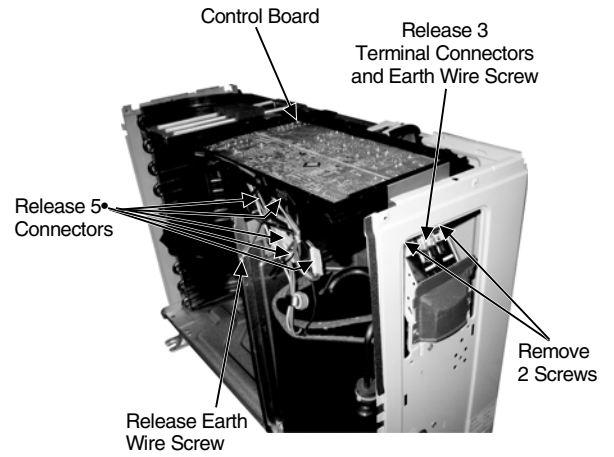

Fig. 4

Remove the Terminal Cover and 3 Terminal Compressor

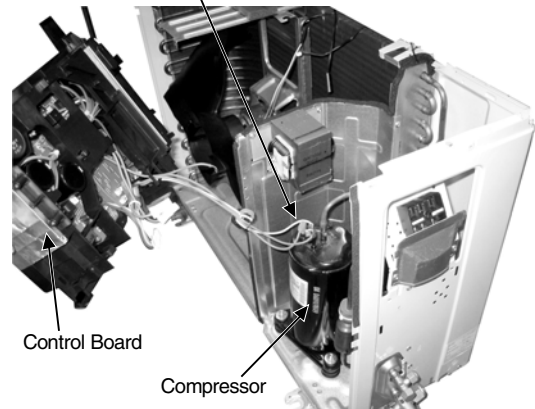

Fig. 5

Electronic Controller

Control Board

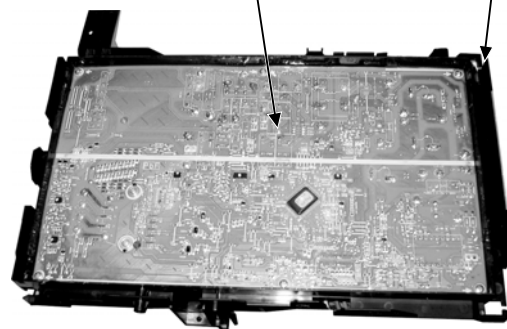

Fig. 6

18.3.2 CU-RE18SKUA CU-RE24SKUA

⚠ Caution! When handling electronic controller, be careful of electrostatic discharge.

- 1 Remove the 8 screws of the Top Panel.

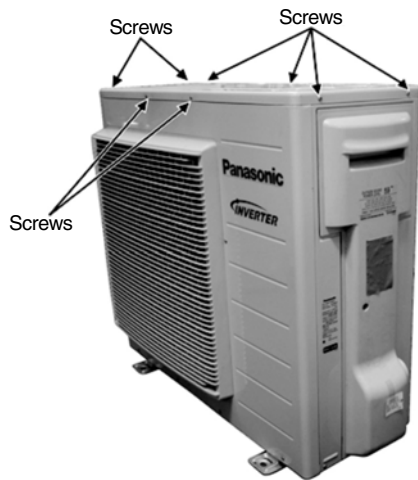

Fig. 1

- 2 Remove the 8 screws of the Front Panel.

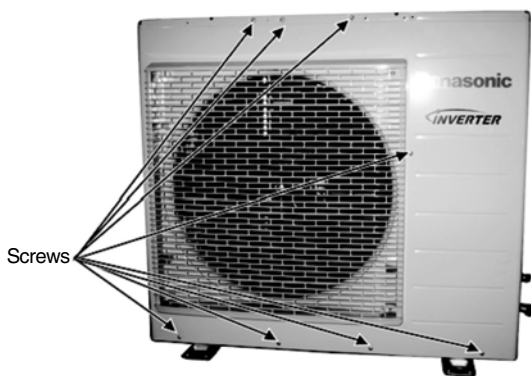

Fig. 2

- 3 Remove the Top Cover of the Electronic Controller.

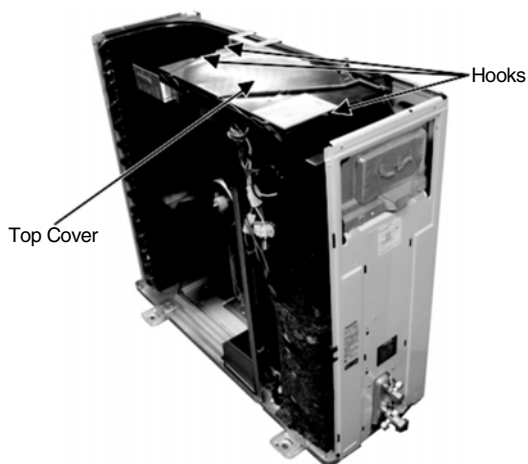

Fig. 3

- 4 Remove the Control Board.

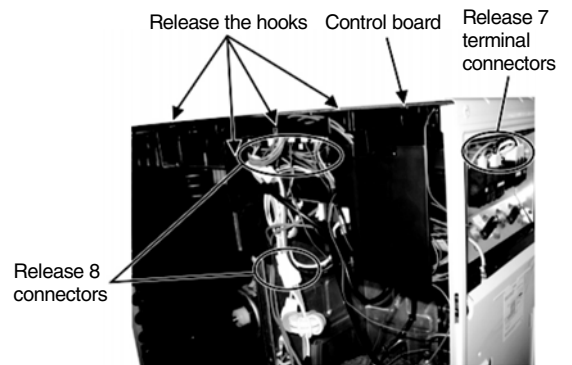

Fig. 4

- 5 Remove the 6 screws of the Electronic Controller.

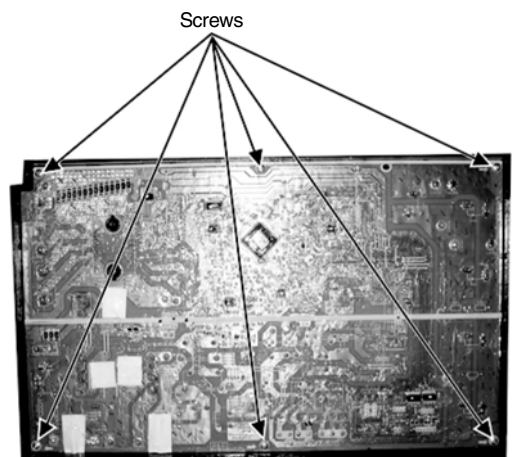

Fig. 5

⚠ Caution! When handling electronic controller, be careful of electrostatic discharge.

19. Technical Data

Technical data provided are based on the air conditioner running under free frequency.

19.1 Cool Mode Performance Data

Unit setting: Standard piping length, Hi Fan, Cool mode at 60.8°F

Voltage: 230V

19.1.1 CS-RE9SKUA CU-RE9SKUA

Indoor (°C / °F)		Outdoor (°C / °F)											
DB	WB	-20 (-4)			-10 (14)			0 (32)			5 (41)		
		TC	SHC	IP	TC	SHC	IP	TC	SHC	IP	TC	SHC	IP
27 (80.6)	19 (66.2)	2966	2683	598	2966	2683	607	2952	2707	593	3013	2763	560
	22 (71.6)	3134	1907	635	3134	1907	646	3153	1935	608	3404	2056	454
23 (73.4)	16 (60.8)	2776	2748	571	2776	2748	580	2683	2656	620	3039	3009	499
	18 (64.4)	2920	1901	641	2920	1901	650	2827	1867	680	2987	1965	577
20 (68)	13 (55.4)	2637	2611	618	2637	2611	628	2543	2518	644	2423	2399	485
	16 (60.8)	2718	1890	629	2718	1890	640	2725	1876	618	2651	1912	506

Indoor (°C / °F)		Outdoor (°C / °F)											
DB	WB	16 (60.8)			25 (77)			35 (95)			46 (114.8)		
		TC	SHC	IP	TC	SHC	IP	TC	SHC	IP	TC	SHC	IP
27 (80.6)	19 (66.2)	3150	2706	508	3147	2820	859	3000	2850	1000	2180	2205	1033
	22 (71.6)	3400	2022	588	3312	1909	788	3194	1979	983	2384	1549	988
23 (73.4)	16 (60.8)	3020	2990	624	2881	2852	884	2765	2737	1013	1982	2207	1070
	18 (64.4)	3010	1951	589	2920	1861	789	2836	2042	999	2176	1561	1031
20 (68)	13 (55.4)	2264	2241	322	2276	2253	664	2540	2515	1017	1550	1706	801
	16 (60.8)	2569	1826	567	2610	1827	813	2582	1960	1007	1940	1528	1055

19.1.2 CS-RE12SKUA CU-RE12SKUA

Indoor (°C / °F)		Outdoor (°C / °F)											
DB	WB	-20 (-4)			-10 (14)			0 (32)			5 (41)		
		TC	SHC	IP	TC	SHC	IP	TC	SHC	IP	TC	SHC	IP
27 (80.6)	19 (66.2)	3943	3568	833	3943	3568	846	3924	3599	825	4006	3674	779
	22 (71.6)	4167	2536	885	4167	2536	899	4193	2573	846	4526	2733	632
23 (73.4)	16 (60.8)	3690	3653	795	3690	3653	807	3567	3531	864	4040	4000	694
	18 (64.4)	3882	2526	815	3882	2526	828	3759	2483	867	3972	2613	732
20 (68)	13 (55.4)	3506	3471	860	3506	3471	874	3382	3348	895	3150	3118	630
	16 (60.8)	3613	2512	877	3613	2512	891	3623	2494	859	3446	2485	658

Indoor (°C / °F)		Outdoor (°C / °F)											
DB	WB	16 (60.8)			25 (77)			35 (95)			46 (114.8)		
		TC	SHC	IP	TC	SHC	IP	TC	SHC	IP	TC	SHC	IP
27 (80.6)	19 (66.2)	4168	3581	692	4091	3665	1116	3900	3705	1300	3010	2867	1377
	22 (71.6)	4420	2628	765	4306	2482	1025	4152	2572	1277	3180	2013	1317
23 (73.4)	16 (60.8)	3926	3887	811	3745	3708	1149	3594	3558	1317	2649	2870	1412
	18 (64.4)	3913	2536	736	3796	2419	1056	3687	2655	1299	2897	2030	1374
20 (68)	13 (55.4)	2943	2914	419	2959	2929	863	3303	3269	1322	2046	2217	1072
	16 (60.8)	3340	2374	737	3393	2376	1057	3356	2548	1309	2583	1986	1407

19.1.3 CS-RE18SKUA CU-RE18SKUA

Indoor (°C / °F)		Outdoor (°C / °F)											
DB	WB	-20 (-4)			-10 (14)			0 (32)			5 (41)		
		TC	SHC	IP	TC	SHC	IP	TC	SHC	IP	TC	SHC	IP
27 (80.6)	19 (66.2)	6210	5368	1007	6203	5363	995	6196	5459	965	6179	5338	957
	22 (71.6)	7123	4388	880	7116	4383	869	6784	4288	1008	6327	4020	1005
23 (73.4)	16 (60.8)	5465	5410	1111	5459	5405	1098	5804	5746	914	5533	5478	1013
	18 (64.4)	6109	4130	1017	6103	4125	1005	6800	4449	795	6336	3893	1058
20 (68)	13 (55.4)	4811	4763	1103	4806	4758	1089	4775	4727	723	4602	4556	865
	16 (60.8)	4798	3640	1273	4793	3637	1257	5023	3759	752	5430	4014	742

Indoor (°C / °F)		Outdoor (°C / °F)											
DB	WB	16 (60.8)			25 (77)			35 (95)			46 (114.8)		
		TC	SHC	IP	TC	SHC	IP	TC	SHC	IP	TC	SHC	IP
27 (80.6)	19 (66.2)	6155	5408	944	5700	4909	1351	5270	5007	1550	4324	4582	1721
	22 (71.6)	6667	3963	942	6390	3892	1371	5915	3128	1570	4719	3218	1643
23 (73.4)	16 (60.8)	6009	5299	981	5283	4976	1316	4923	4774	1637	3917	3878	1752
	18 (64.4)	6589	3794	1000	5777	3622	1320	5421	3714	1667	4304	3244	1701
20 (68)	13 (55.4)	4989	4939	790	5001	4493	1351	4647	4403	1608	3027	2996	1353
	16 (60.8)	5679	4572	1280	5921	3875	1699	5152	2063	1751	3833	3174	1731

19.1.4 CS-RE24SKUA CU-RE24SKUA

Indoor (°C / °F)		Outdoor (°C / °F)											
DB	WB	-20 (-4)			-10 (14)			0 (32)			5 (41)		
		TC	SHC	IP	TC	SHC	IP	TC	SHC	IP	TC	SHC	IP
27 (80.6)	19 (66.2)	7947	6870	1720	7939	6863	1699	7929	6986	1648	7907	6831	1633
	22 (71.6)	9116	5615	1503	9107	5610	1484	8681	5487	1721	8097	5145	1717
23 (73.4)	16 (60.8)	6994	6924	1897	6987	6917	1874	7427	7353	1560	7081	7010	1730
	18 (64.4)	7819	5285	1737	7811	5280	1715	8703	5693	1358	8108	4982	1806
20 (68)	13 (55.4)	6156	6095	1882	6150	6089	1859	6111	6049	1235	5890	5831	1476
	16 (60.8)	6141	4659	2173	6134	4654	2147	6428	4811	1284	6949	5137	1267

Indoor (°C / °F)		Outdoor (°C / °F)											
DB	WB	16 (60.8)			25 (77)			35 (95)			46 (114.8)		
		TC	SHC	IP	TC	SHC	IP	TC	SHC	IP	TC	SHC	IP
27 (80.6)	19 (66.2)	7876	6921	1611	7233	6279	2273	6740	6403	2550	5530	5860	2900
	22 (71.6)	8148	5505	1616	7910	4977	2305	7438	4000	2583	6036	4115	2784
23 (73.4)	16 (60.8)	7303	7230	1611	6777	6364	2214	6168	6106	2692	5009	4959	3001
	18 (64.4)	7971	5259	1615	7410	4632	2187	6790	4750	2742	5504	4149	2895
20 (68)	13 (55.4)	6385	6321	1349	6300	5746	2123	5687	5631	2645	3871	3832	2254
	16 (60.8)	7268	5850	2186	7457	4956	2731	6353	2638	2881	4903	4060	2967

TC : Total capacity (BTU)

SHC: Sensible Heat Capacity (BTU)

IP: Input Power (Watt)

19.2 Heat Mode Performance Data

Unit setting: Standard piping length, Hi Fan, Heat mode at 86°F
Voltage: 230V

19.2.1 CS-RE9SKUA CU-RE9SKUA

Indoor (°C / °F)	Outdoor (°C / °F)											
	-20 (-4)		-8.3 (17.06)		1.7 (35.06)		8.3 (46.94)		12 (53.6)		23.9 (75.02)	
DB	TC	IP	TC	IP	TC	IP	TC	IP	TC	IP	TC	IP
24 (75.2)	1266	1301	2478	1320	3146	1459	4157	1512	4259	1525	4462	1424
20 (68)	1329	1295	2639	1315	3230	1431	4140	1500	4217	1491	4716	1393
16 (60.8)	1092	1261	2708	1301	3477	1443	4443	1539	4470	1466	4601	1369

19.2.2 CS-RE12SKUA CU-RE12SKUA

Indoor (°C / °F)	Outdoor (°C / °F)											
	-20 (-4)		-8.3 (17.06)		1.7 (35.06)		8.3 (46.94)		12 (53.6)		23.9 (75.02)	
DB	TC	IP	TC	IP	TC	IP	TC	IP	TC	IP	TC	IP
24 (75.2)	1375	1483	2696	1505	3421	1663	4789	1724	4908	1738	5141	1623
20 (68)	1444	1476	2872	1499	3513	1631	4770	1710	4859	1700	5434	1588
16 (60.8)	1185	1438	2947	1484	3783	1645	5119	1755	5151	1671	5301	1561

19.2.3 CS-RE18SKUA CU-RE18SKUA

Indoor (°C / °F)	Outdoor (°C / °F)											
	-20 (-4)		-8.3 (17.06)		1.7 (35.06)		8.3 (46.94)		12 (53.6)		23.9 (75.02)	
DB	TC	IP	TC	IP	TC	IP	TC	IP	TC	IP	TC	IP
24 (75.2)	2743	1629	4127	1729	5109	1698	5962	1850	6223	1839	6711	1734
20 (68)	2824	1574	4140	1657	5183	1592	6120	1750	6470	1765	6978	1664
16 (60.8)	2637	1501	4175	1578	5239	1532	6272	1654	6644	1671	7165	1575

19.2.4 CS-RE24SKUA CU-RE24SKUA

Indoor (°C / °F)	Outdoor (°C / °F)											
	-20 (-4)		-8.3 (17.06)		1.7 (35.06)		8.3 (46.94)		12 (53.6)		23.9 (75.02)	
DB	TC	IP	TC	IP	TC	IP	TC	IP	TC	IP	TC	IP
24 (75.2)	3335	2360	5017	2500	6211	2457	7248	2590	7565	2575	8158	2427
20 (68)	3433	2284	5032	2400	6301	2309	7440	2450	7866	2471	8483	2329
16 (60.8)	3206	2182	5076	2289	6369	2224	7625	2316	8077	2340	8711	2205

TC : Total capacity (BTU)

IP: Input Power (Watt)

20. Service Data

Service data provided are based on the air conditioner running under rated frequency during forced cooling / forced heating mode.

20.1 CS-RE9SKUA CU-RE9SKUA

Rated frequency (compressor speed is fixed during forced cooling for capacity measurement and diagnosis purpose)

Indoor (°C / °F)		Outdoor (°C / °F)											
DB	WB	-20 (-4)			-10 (14)			0 (32)			5 (41)		
		TC	SHC	IP	TC	SHC	IP	TC	SHC	IP	TC	SHC	IP
27 (80.6)	19 (66.2)	2966	2683	634	2966	2683	644	2952	2707	628	3013	2763	593
	22 (71.6)	3134	1907	673	3134	1907	684	3153	1935	644	3404	2056	481
23 (73.4)	16 (60.8)	2776	2748	605	2776	2748	615	2683	2656	657	3039	3008	528
	18 (64.4)	2920	1900	621	2920	1900	630	2827	1868	660	2987	1965	557
20 (68)	13 (55.4)	2637	2611	655	2637	2611	665	2543	2518	681	2331	2308	467
	16 (60.8)	2718	1889	667	2718	1889	678	2725	1876	654	2454	1769	443

Indoor (°C / °F)		Outdoor (°C / °F)											
DB	WB	16 (60.8)			25 (77)			35 (95)			46 (114.8)		
		TC	SHC	IP	TC	SHC	IP	TC	SHC	IP	TC	SHC	IP
27 (80.6)	19 (66.2)	3135	2693	527	2770	2481	769	2640	2508	860	2166	1941	1033
	22 (71.6)	3238	1925	524	3023	1742	735	2811	1741	845	2364	1363	987
23 (73.4)	16 (60.8)	2781	2753	590	2509	2484	789	2433	2409	871	1962	1943	1059
	18 (64.4)	2941	1906	569	2757	1757	768	2495	1797	860	2156	1374	1031
20 (68)	13 (55.4)	2061	2040	261	2042	2022	596	2236	2213	874	1516	1501	800
	16 (60.8)	2363	1679	501	2455	1719	786	2272	1725	866	1920	1344	1055

20.2 CS-RE12SKUA CU-RE12SKUA

Rated frequency (compressor speed is fixed during forced cooling for capacity measurement and diagnosis purpose)

Indoor (°C / °F)		Outdoor (°C / °F)											
DB	WB	-20 (-4)			-10 (14)			0 (32)			5 (41)		
		TC	SHC	IP	TC	SHC	IP	TC	SHC	IP	TC	SHC	IP
27 (80.6)	19 (66.2)	3943	3568	833	3943	3568	846	3924	3599	825	4006	3674	779
	22 (71.6)	4167	2536	885	4167	2536	899	4193	2573	846	4526	2733	632
23 (73.4)	16 (60.8)	3690	3653	795	3690	3653	807	3567	3531	864	4040	4000	694
	18 (64.4)	3882	2526	815	3882	2526	828	3759	2483	867	3972	2613	732
20 (68)	13 (55.4)	3506	3471	860	3506	3471	874	3382	3348	895	3099	3068	614
	16 (60.8)	3613	2512	877	3613	2512	891	3623	2494	859	3262	2352	582

Indoor (°C / °F)		Outdoor (°C / °F)											
DB	WB	16 (60.8)			25 (77)			35 (95)			46 (114.8)		
		TC	SHC	IP	TC	SHC	IP	TC	SHC	IP	TC	SHC	IP
27 (80.6)	19 (66.2)	4168	3581	692	3682	3299	1010	3510	3335	1130	2880	2580	1357
	22 (71.6)	4305	2560	688	4019	2317	966	3737	2315	1110	3143	1812	1297
23 (73.4)	16 (60.8)	3697	3660	775	3335	3302	1036	3235	3202	1145	2609	2583	1392
	18 (64.4)	3910	2534	747	3665	2336	1008	3318	2390	1129	2867	1827	1354
20 (68)	13 (55.4)	2740	2712	342	2716	2688	783	2972	2943	1149	2016	1996	1052
	16 (60.8)	3141	2233	659	3264	2285	1032	3021	2294	1138	2553	1788	1387

20.3 CS-RE18SKUA CU-RE18SKUA

Rated frequency (compressor speed is fixed during forced cooling for capacity measurement and diagnosis purpose)

Indoor (°C / °F)		Outdoor (°C / °F)											
DB	WB	-20 (-4)			-10 (14)			0 (32)			5 (41)		
		TC	SHC	IP	TC	SHC	IP	TC	SHC	IP	TC	SHC	IP
27 (80.6)	19 (66.2)	6210	5368	1007	6203	5363	995	6196	5459	965	6179	5338	957
	22 (71.6)	7123	4388	880	7116	4383	869	6784	4288	1008	6327	4020	1005
23 (73.4)	16 (60.8)	5465	5410	1111	5459	5405	1098	5804	5746	914	5533	5478	1013
	18 (64.4)	6109	4130	1017	6103	4125	1005	6800	4449	795	6336	3893	1058
20 (68)	13 (55.4)	4811	4763	1103	4806	4758	1089	4775	4727	723	4602	4556	865
	16 (60.8)	4798	3640	1273	4793	3637	1257	5023	3759	752	5430	4014	742

Indoor (°C / °F)		Outdoor (°C / °F)											
DB	WB	16 (60.8)			25 (77)			35 (95)			46 (114.8)		
		TC	SHC	IP	TC	SHC	IP	TC	SHC	IP	TC	SHC	IP
27 (80.6)	19 (66.2)	6155	5408	944	5386	4808	1286	5040	4788	1400	4136	4382	1681
	22 (71.6)	6367	4301	947	5856	3805	1300	5562	2991	1418	4513	3077	1607
23 (73.4)	16 (60.8)	5707	5650	944	4983	4933	1262	4612	4566	1478	3746	3708	1725
	18 (64.4)	6229	4109	946	5477	3662	1276	5077	3552	1505	4116	3103	1678
20 (68)	13 (55.4)	4989	4939	790	4667	4620	1261	4253	4210	1452	2895	2866	1303
	16 (60.8)	5679	4572	1280	5593	3985	1619	4751	1973	1582	3666	3036	1718

20.4 CS-RE24SKUA CU-RE24SKUA

Rated frequency (compressor speed is fixed during forced cooling for capacity measurement and diagnosis purpose)

Indoor (°C / °F)		Outdoor (°C / °F)											
DB	WB	-20 (-4)			-10 (14)			0 (32)			5 (41)		
		TC	SHC	IP	TC	SHC	IP	TC	SHC	IP	TC	SHC	IP
27 (80.6)	19 (66.2)	7947	6870	1720	7939	6863	1699	7929	6986	1648	7907	6831	1633
	22 (71.6)	9116	5615	1503	9107	5610	1484	8681	5487	1721	8097	5145	1717
23 (73.4)	16 (60.8)	6994	6924	1897	6987	6917	1874	7427	7353	1560	7081	7010	1730
	18 (64.4)	7819	5285	1737	7811	5280	1715	8703	5693	1358	8108	4982	1806
20 (68)	13 (55.4)	6156	6095	1882	6150	6089	1859	6111	6049	1235	5890	5831	1476
	16 (60.8)	6141	4659	2173	6134	4654	2147	6428	4811	1284	6949	5137	1267

Indoor (°C / °F)		Outdoor (°C / °F)											
DB	WB	16 (60.8)			25 (77)			35 (95)			46 (114.8)		
		TC	SHC	IP	TC	SHC	IP	TC	SHC	IP	TC	SHC	IP
27 (80.6)	19 (66.2)	7876	6921	1611	6892	6153	2196	6450	6128	2390	5292	5608	2870
	22 (71.6)	8148	5505	1616	7495	4870	2220	7118	3828	2421	5776	3938	2744
23 (73.4)	16 (60.8)	7303	7230	1611	6377	6313	2155	5902	5843	2523	4794	4746	2944
	18 (64.4)	7971	5259	1615	7010	4687	2178	6498	4546	2570	5268	3971	2865
20 (68)	13 (55.4)	6385	6321	1349	5973	5913	2153	5443	5388	2479	3704	3667	2224
	16 (60.8)	7268	5850	2186	7157	5100	2763	6080	2525	2701	4692	3885	2933

TC : Total capacity (BTU)

SHC: Sensible Heat Capacity (BTU)

IP: Input Power (Watt)

20.5 CS-RE9SKUA CU-RE9SKUA

Rated frequency (compressor speed is fixed during forced heating for capacity measurement and diagnosis purpose)

Indoor (°C / °F)	Outdoor (°C / °F)											
	-20 (-4)		-8.3 (17.06)		1.7 (35.06)		8.3 (46.94)		12 (53.6)		23.9 (75.02)	
DB	TC	IP	TC	IP	TC	IP	TC	IP	TC	IP	TC	IP
24 (75.2)	1166	633	2328	881	2946	957	3223	958	3307	974	3600	945
20 (68)	1229	625	2489	878	3030	939	3210	950	3275	953	3805	924
16 (60.8)	992	609	2558	869	3277	946	3445	975	3471	937	3713	908

20.6 CS-RE12SKUA CU-RE12SKUA

Rated frequency (compressor speed is fixed during forced heating for capacity measurement and diagnosis purpose)

Indoor (°C / °F)	Outdoor (°C / °F)											
	-20 (-4)		-8.3 (17.06)		1.7 (35.06)		8.3 (46.94)		12 (53.6)		23.9 (75.02)	
DB	TC	IP	TC	IP	TC	IP	TC	IP	TC	IP	TC	IP
24 (75.2)	1275	607	2546	844	3221	917	3524	917	3617	933	3937	905
20 (68)	1344	598	2722	841	3313	899	3510	910	3581	913	4161	885
16 (60.8)	1085	584	2797	832	3583	907	3767	934	3796	897	4059	870

20.7 CS-RE18SKUA CU-RE18SKUA

Rated frequency (compressor speed is fixed during forced heating for capacity measurement and diagnosis purpose)

Indoor (°C / °F)	Outdoor (°C / °F)											
	-20 (-4)		-8.3 (17.06)		1.7 (35.06)		8.3 (46.94)		12 (53.6)		23.9 (75.02)	
DB	TC	IP	TC	IP	TC	IP	TC	IP	TC	IP	TC	IP
24 (75.2)	1642	957	3073	1274	3924	1284	5144	1459	5370	1451	5788	1393
20 (68)	1690	922	3083	1225	3981	1231	5280	1380	5584	1392	6018	1337
16 (60.8)	1578	881	3109	1171	4024	1179	5411	1305	5734	1318	6179	1266

20.8 CS-RE24SKUA CU-RE24SKUA

Rated frequency (compressor speed is fixed during forced heating for capacity measurement and diagnosis purpose)

Indoor (°C / °F)	Outdoor (°C / °F)											
	-20 (-4)		-8.3 (17.06)		1.7 (35.06)		8.3 (46.94)		12 (53.6)		23.9 (75.02)	
DB	TC	IP	TC	IP	TC	IP	TC	IP	TC	IP	TC	IP
24 (75.2)	2005	1234	3754	1643	4793	1656	6284	1882	6560	1871	7070	1797
20 (68)	2064	1189	3766	1581	4863	1588	6450	1780	6822	1795	7352	1724
16 (60.8)	1928	1136	3798	1511	4915	1521	6610	1683	7005	1700	7549	1633

TC : Total capacity (BTU)

IP: Input Power (Watt)

20.9 Cool Mode Outdoor Air Temperature Characteristic

Condition

- Indoor room temperature: 80°F Dry Bulb/67°F Wet Bulb
- Unit setting: Standard piping length, forced cooling at 60.8°F, Hi fan
- Compressor frequency: Rated for cooling operation
- Piping length: 7.5m
- Voltage: 208/230V

20.9.1 CS-RE9SKUA CU-RE9SKUA

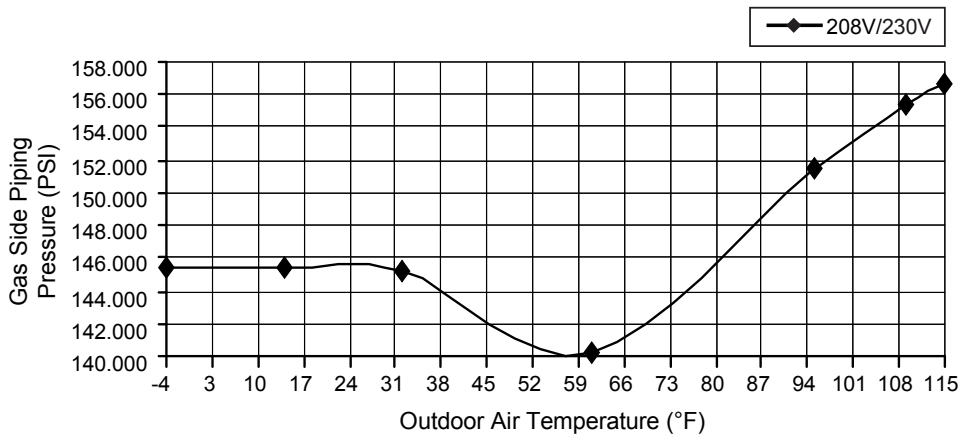
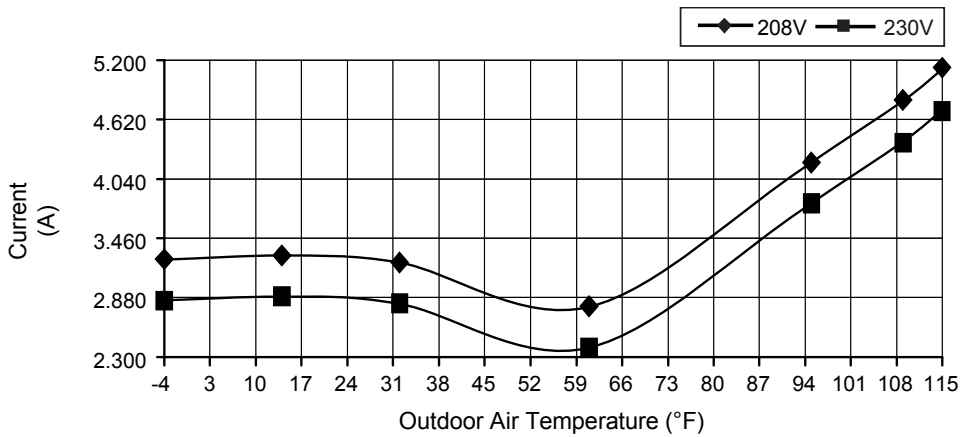
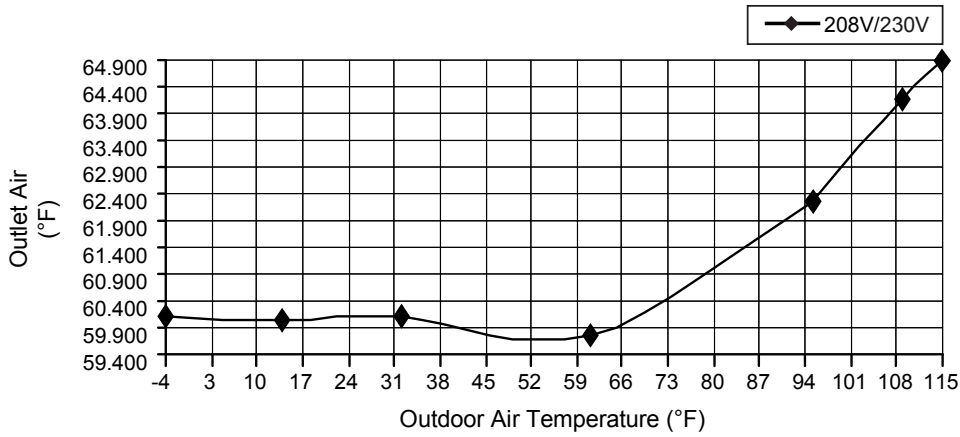

20.9.2 CS-RE12SKUA CU-RE12SKUA

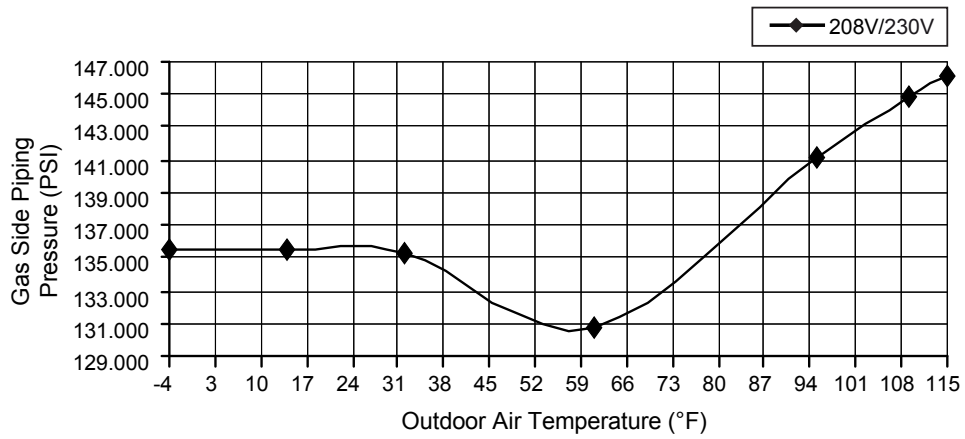
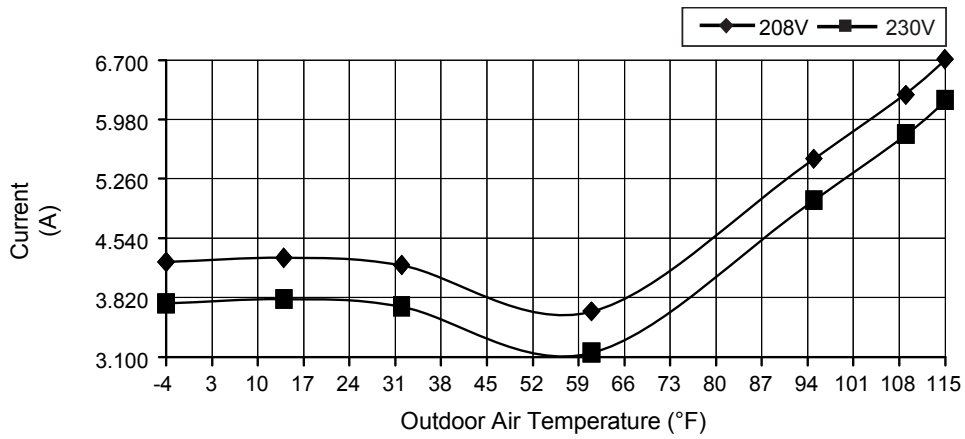
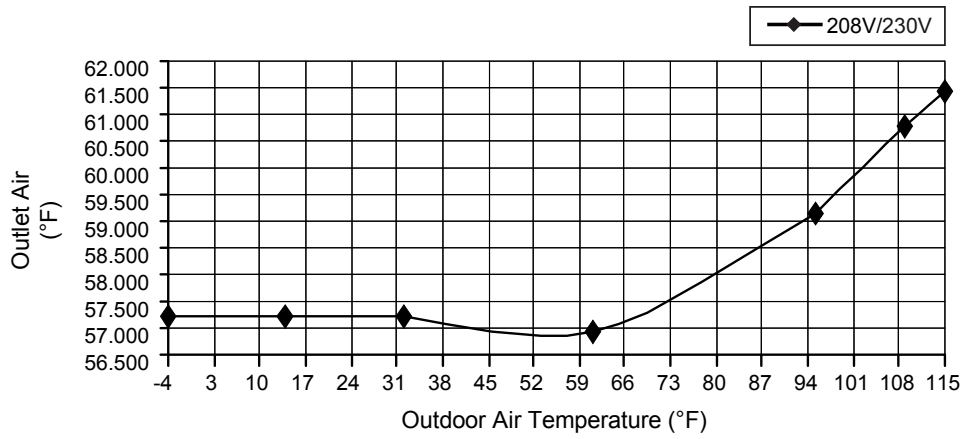

20.9.3 CS-RE18SKUA CU-RE18SKUA

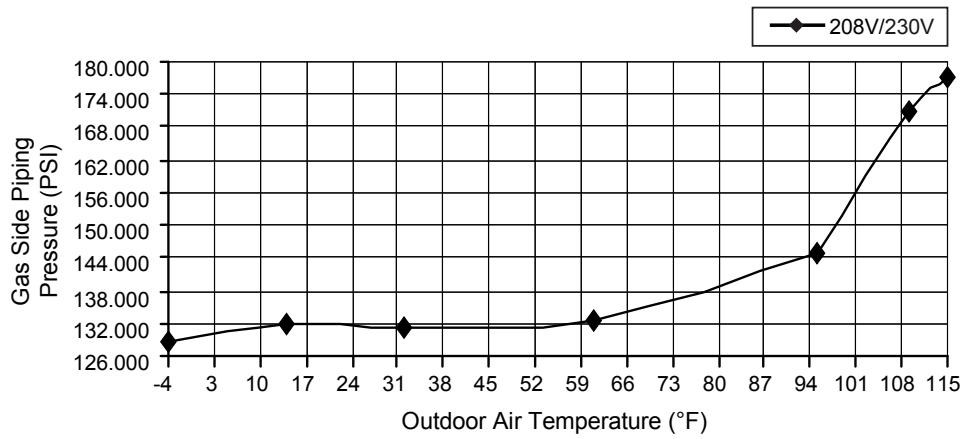
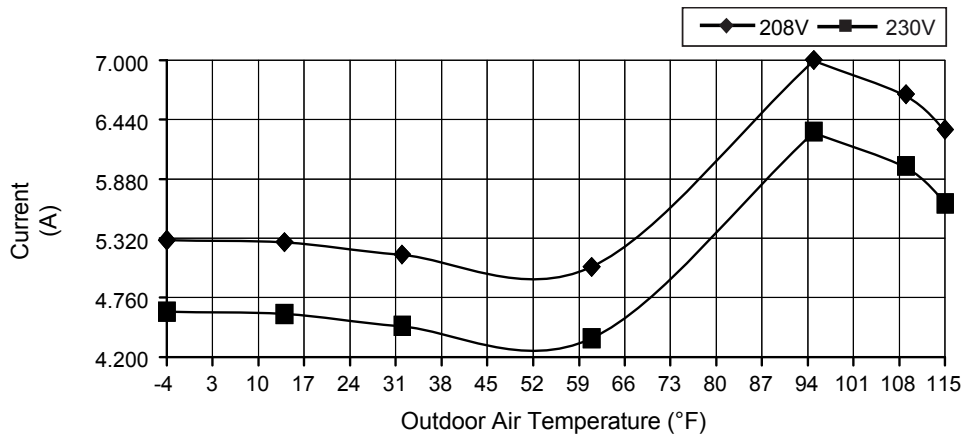
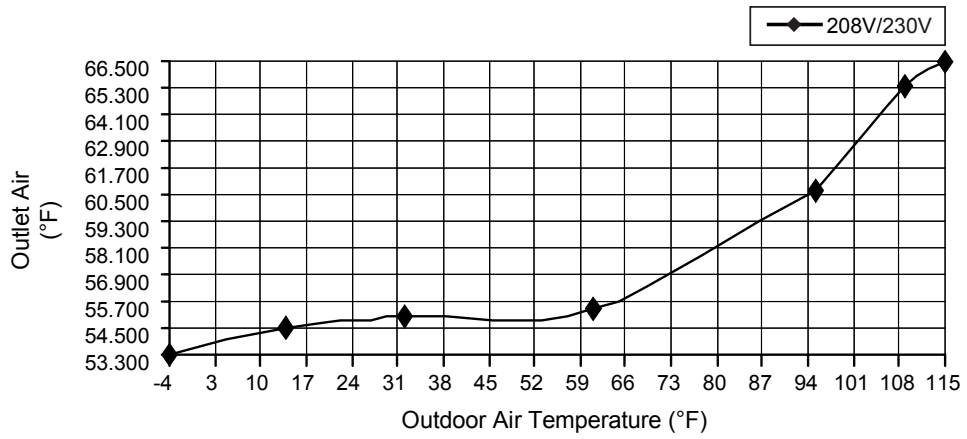

20.9.4 CS-RE24SKUA CU-RE24SKUA

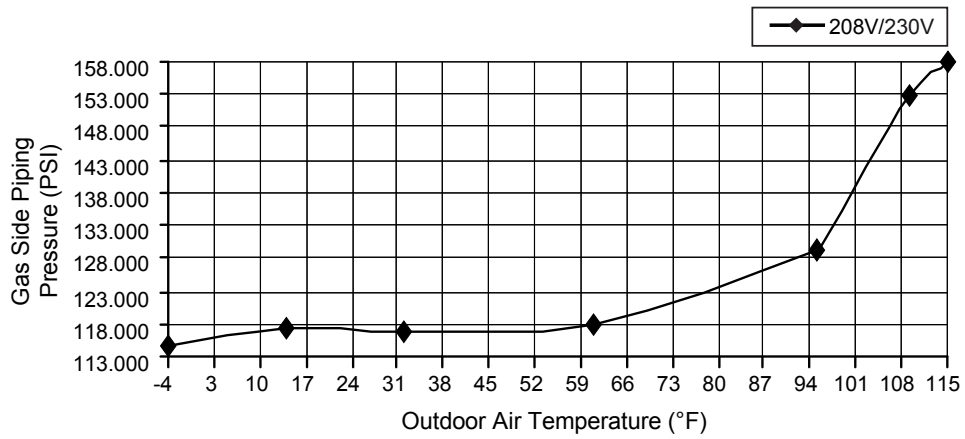
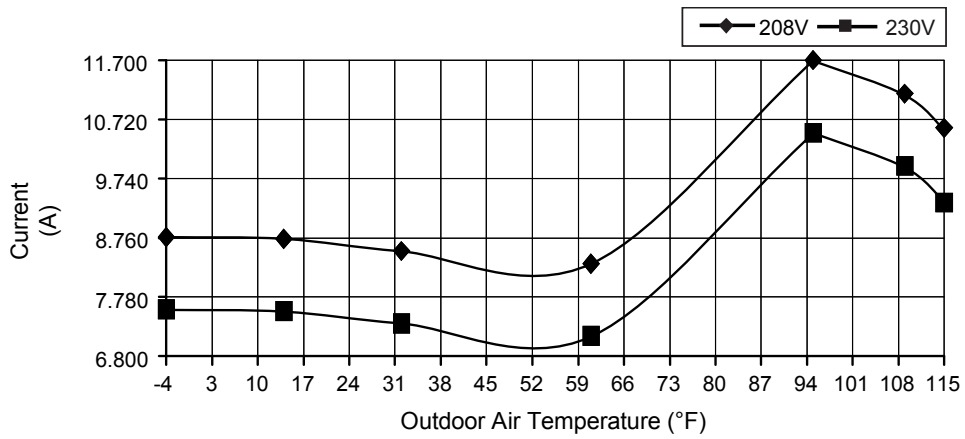
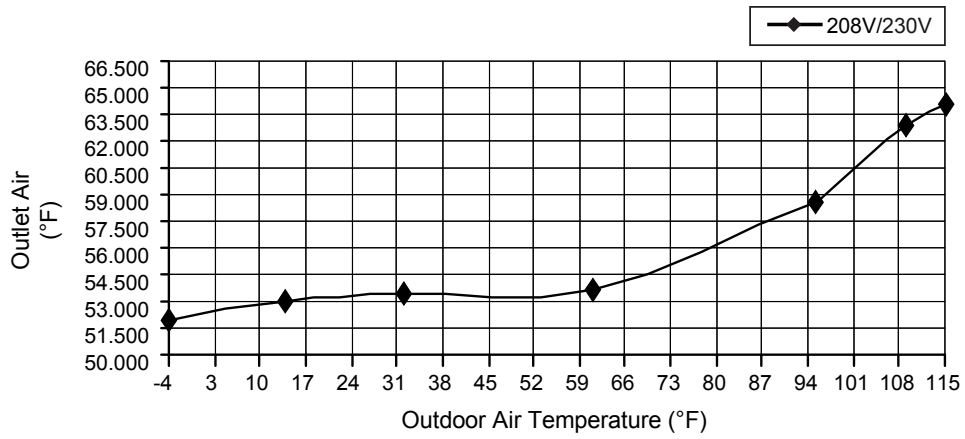

20.10 Heat Mode Outdoor Air Temperature Characteristic

Condition

- Indoor room temperature: 68°F Dry Bulb/-°F Wet Bulb
- Unit setting: Standard piping length, forced heating at 86°F, Hi fan
- Compressor frequency: Rated for Heating operation
- Piping length: 7.5m
- Voltage: 208/230V

20.10.1 CS-RE9SKUA CU-RE9SKUA

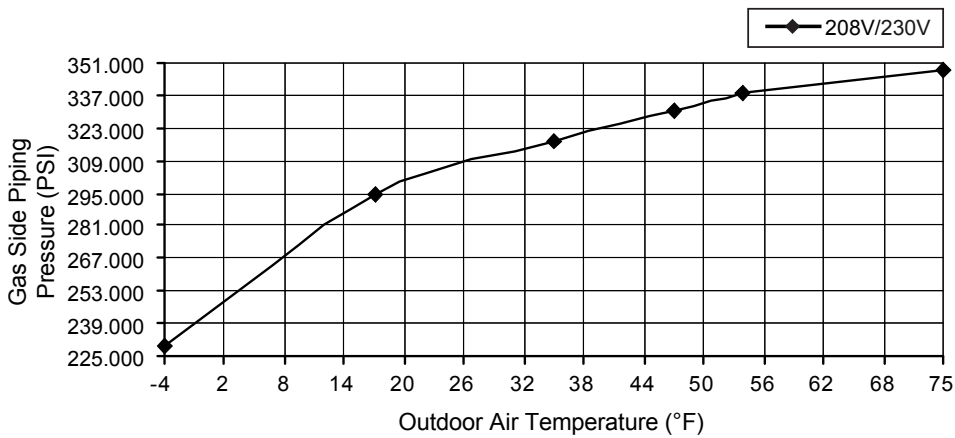
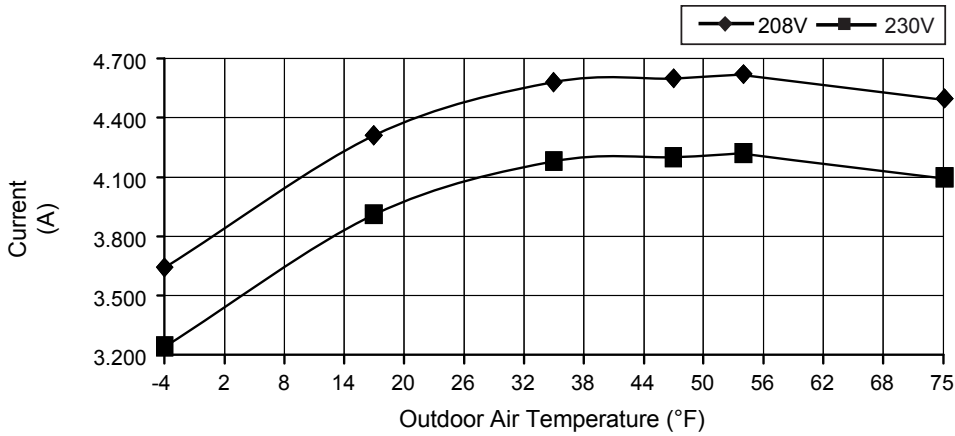
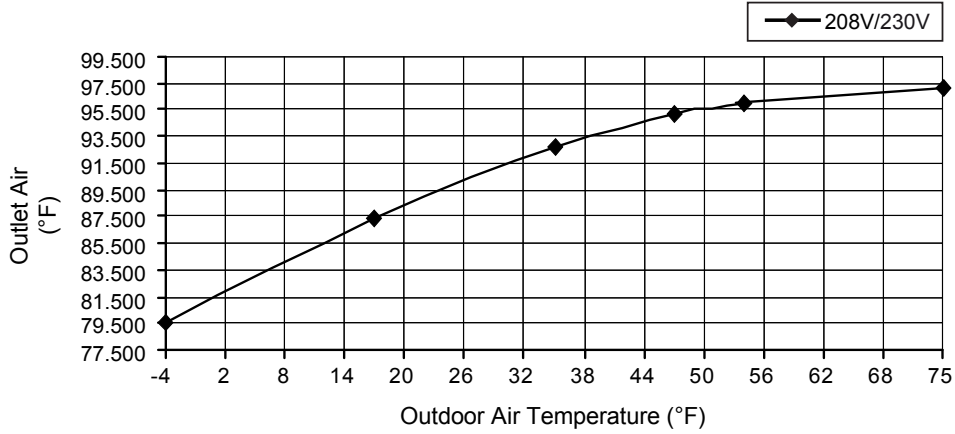

20.10.2 CS-RE12SKUA CU-RE12SKUA

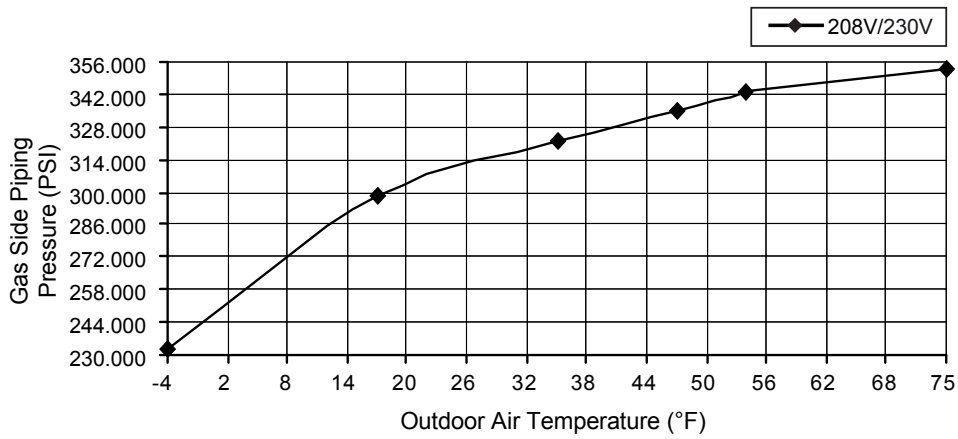
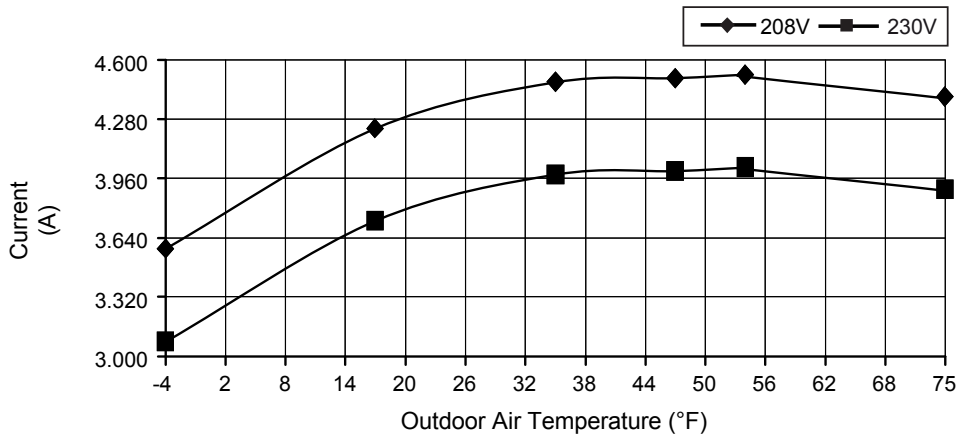
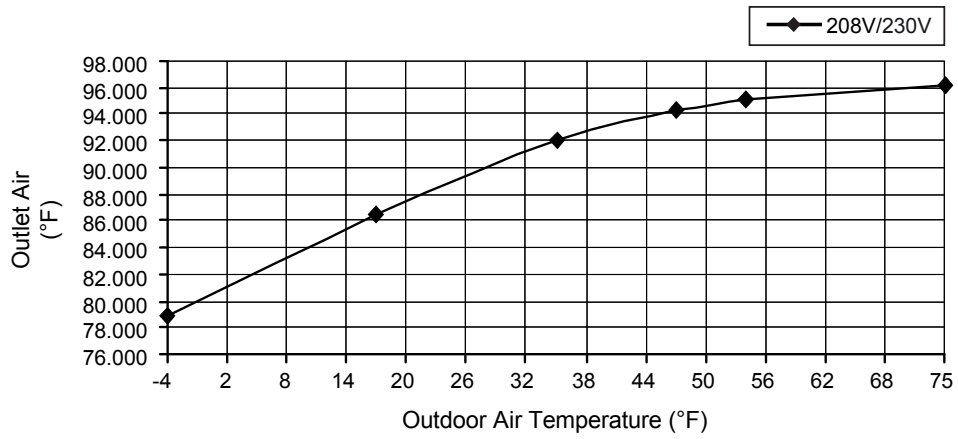

20.10.3 CS-RE18SKUA CU-RE18SKUA

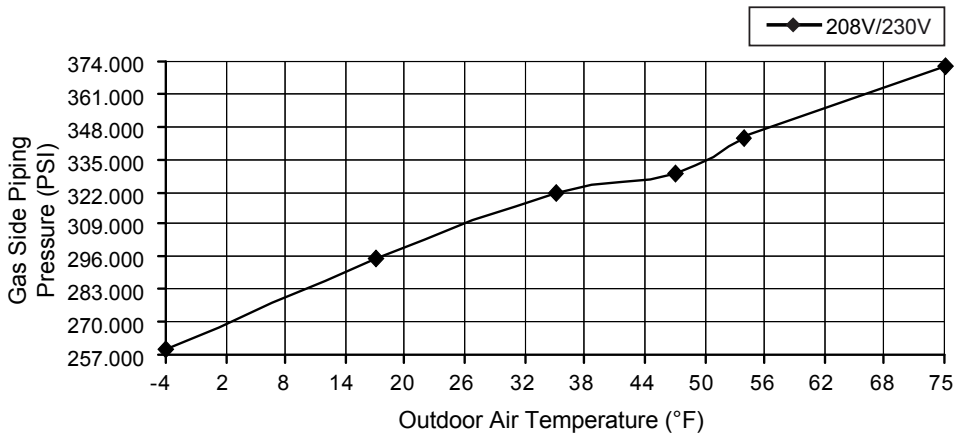
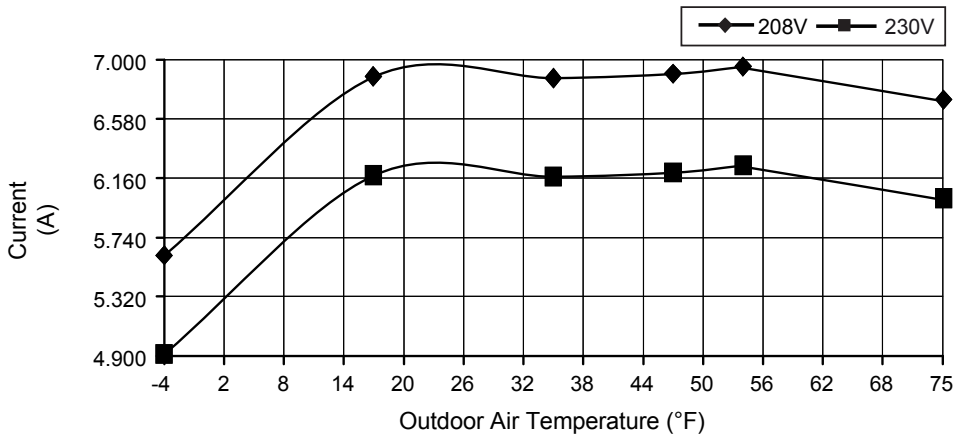
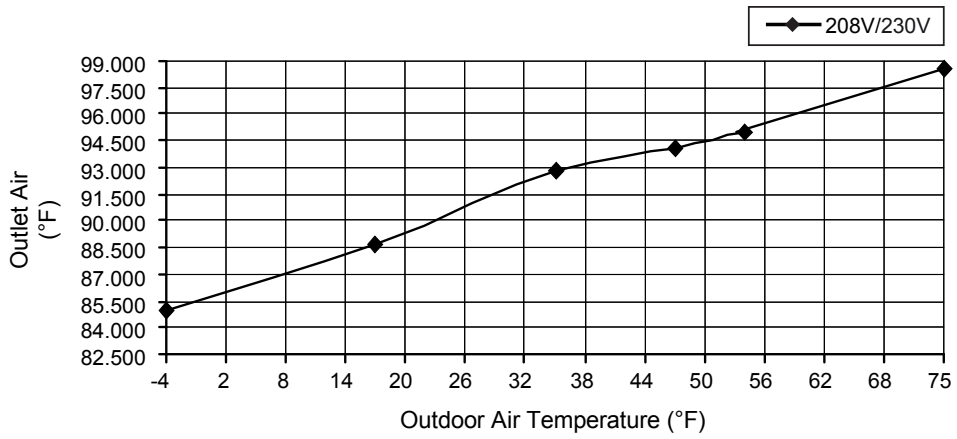

20.10.4 CS-RE24SKUA CU-RE24SKUA

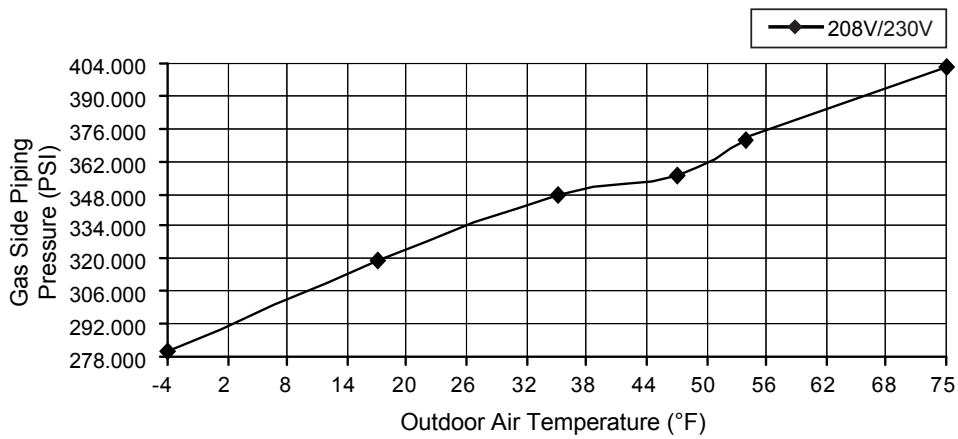
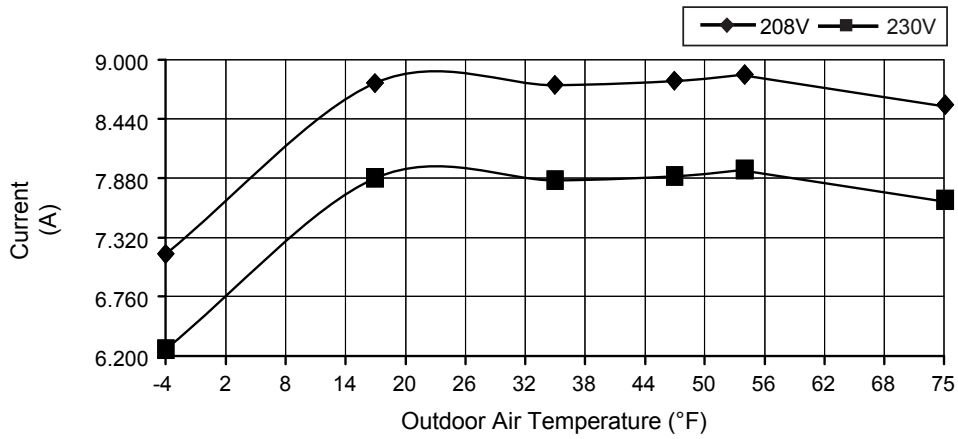
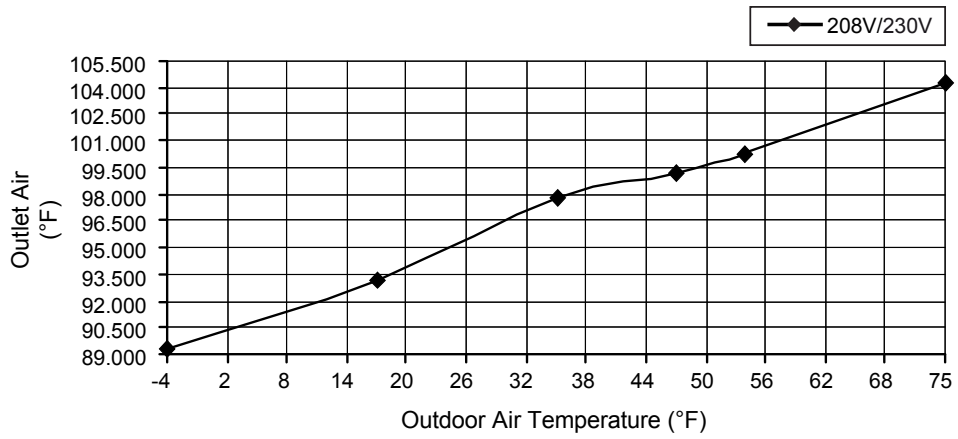

20.11 Piping Length Correction Factor

The characteristic of the unit has to be corrected in accordance with the piping length.

20.11.1 CS-RE9SKUA CU-RE9SKUA CS-RE12SKUA CU-RE12SKUA

20.11.1.1 Cooling Capacity

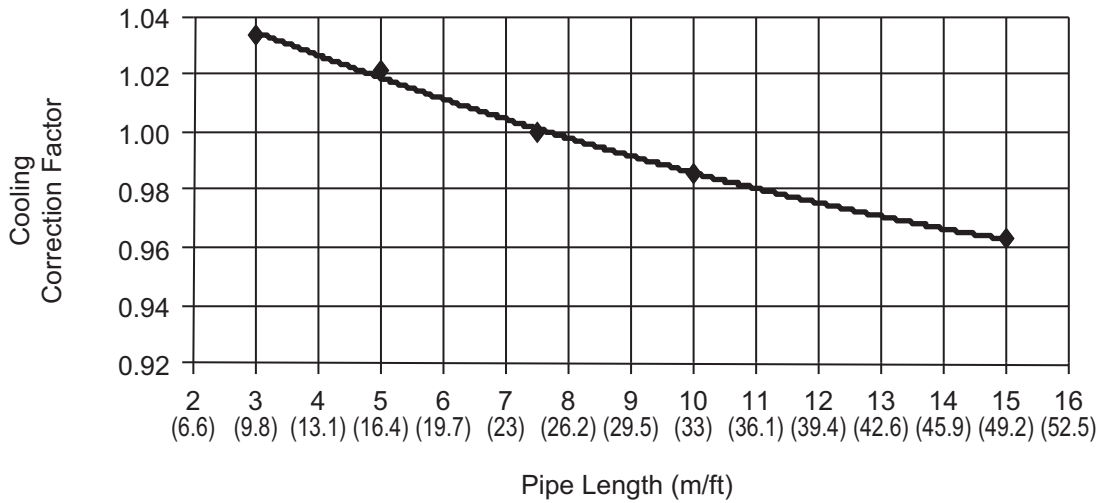

Piping length	Capacity (kW)
3 (9.8)	1.0334
5 (16.4)	1.0213
7.5 (24.6)	1.0000
10 (32.8)	0.9855
15 (49.2)	0.9629

20.11.1.2 Heating Capacity

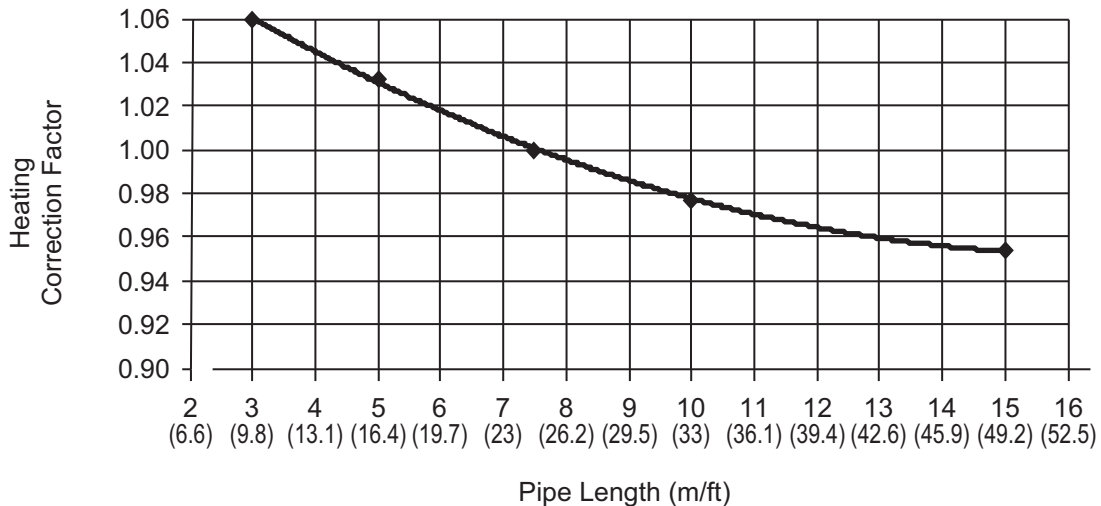

Piping length	Capacity (kW)
3 (9.8)	1.0593
5 (16.4)	1.0323
7.5 (24.6)	1.0000
10 (32.8)	0.9771
15 (49.2)	0.9536

Note: The graphs show the factor after added right amount of additional refrigerant.

20.11.2 CS-RE18SKUA CU-RE18SKUA CS-RE24SKUA CU-RE24SKUA

20.11.2.1 Cooling Capacity

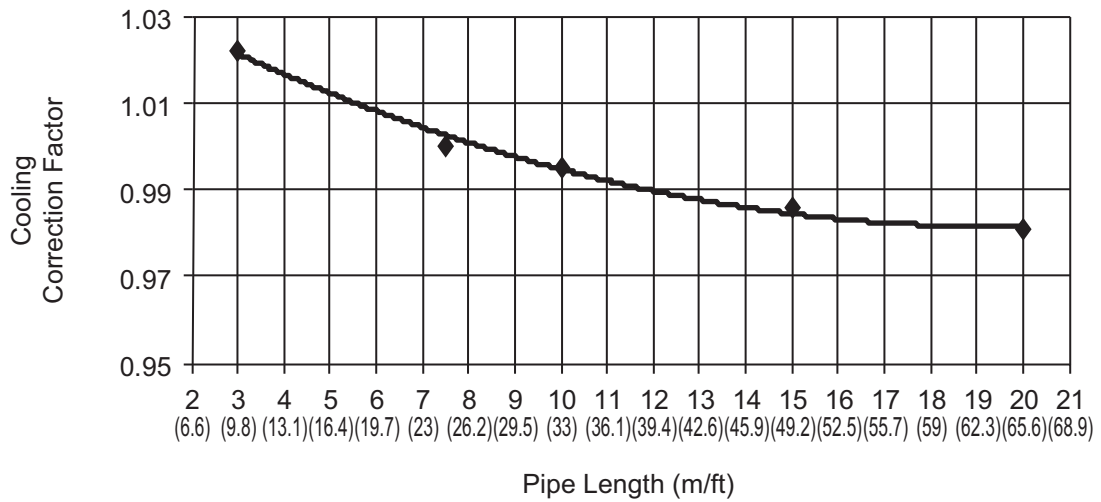

Piping length	Capacity (kW)
3 (9.8)	1.0222
7.5 (24.6)	1.0000
10 (32.8)	0.9950
15 (49.2)	0.9861
20 (65.6)	0.9807

20.11.2.2 Heating Capacity

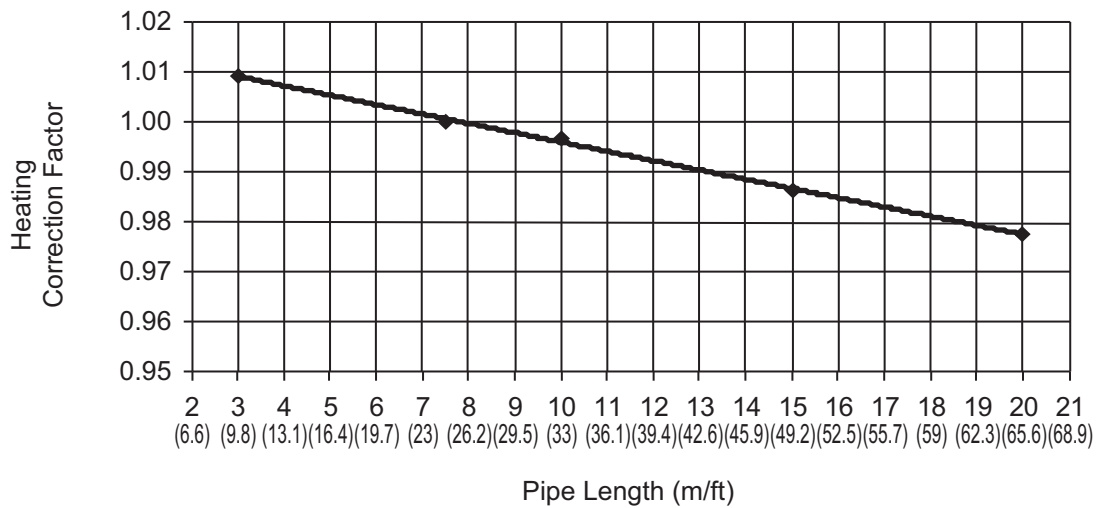

Piping length	Capacity (kW)
3 (9.8)	1.0089
7.5 (24.6)	1.0000
10 (32.8)	0.9964
15 (49.2)	0.9861
20 (65.6)	0.9773

Note: The graphs show the factor after added right amount of additional refrigerant.

21. Exploded View and Replacement Parts List

21.1 Indoor Unit

21.1.1 CS-RE9SKUA CS-RE12SKUA

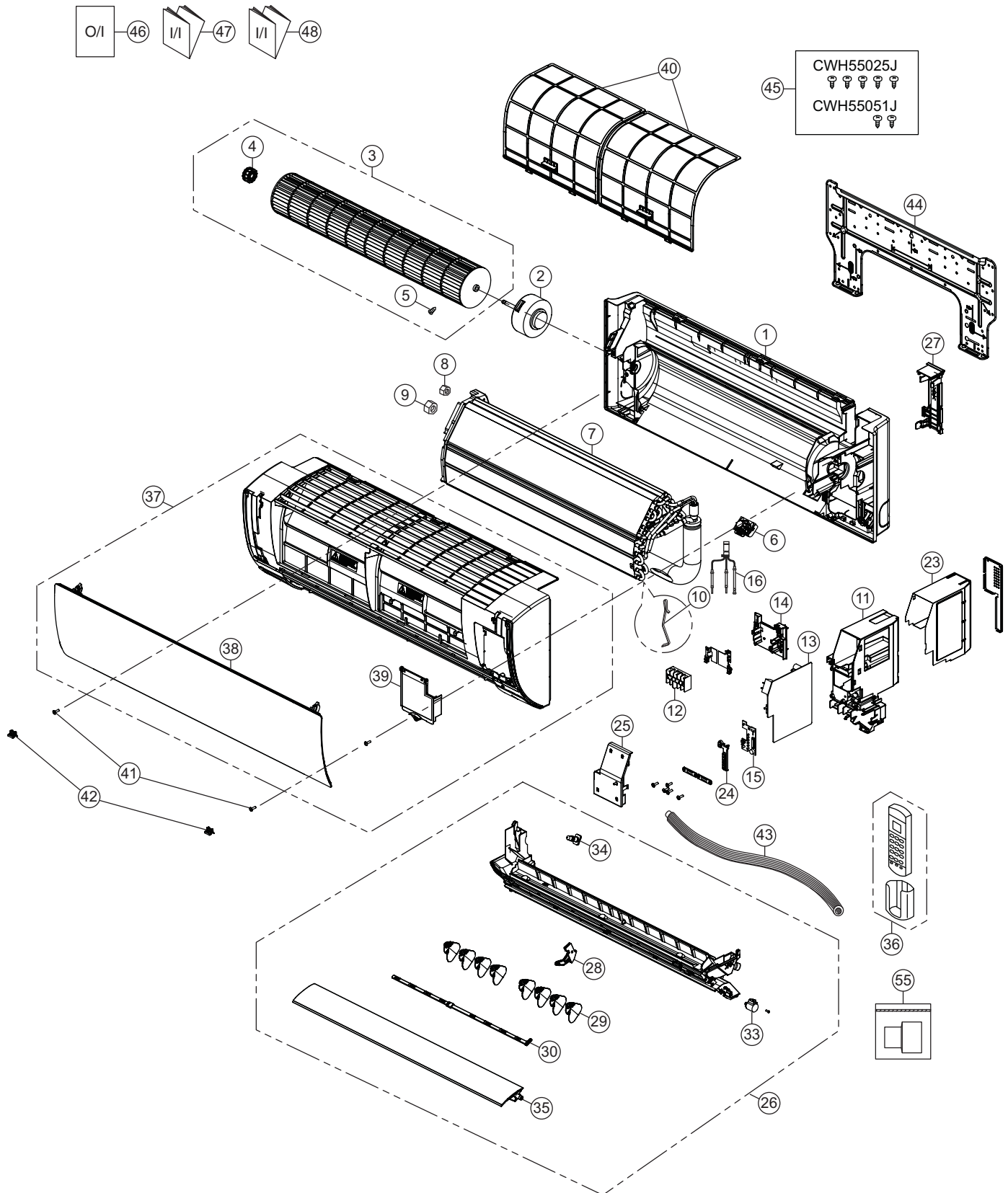

Note
The above exploded view is for the purpose of parts disassembly and replacement.
The non-numbered parts are not kept as standard service parts.

SAFETY	REF. NO.	PART NAME & DESCRIPTION	QTY.	CS-RE9SKUA	CS-RE12SKUA	REMARK
	1	CHASSIS COMPLETE	1	CWD50C1633	←	
	2	FAN MOTOR	1	L6CBYYYYL0055	←	O
	3	CROSS - FLOW FAN COMPLETE	1	CWH02C1076	←	
	4	BEARING ASSY	1	CWH64K1010	←	O
	5	SCREW - CROSS-FLOW FAN	1	CWH551146	←	
	6	PARTICULAR PIECE	1	CWD933067	←	
	7	EVAPORATOR	1	ACXB30C00800	ACXB30C00810	
	8	FLARE NUT (LIQUID)	1	CWT251048	←	
	9	FLARE NUT (GAS)	1	CWT251049	CWT251032	
	10	CLIP FOR SENSOR	1	CWH321085	←	
	11	CONTROL BOARD CASING	1	CWH102605A	←	
	12	TERMINAL BOARD COMPLETE	1	CWA28C2357	←	O
	13	ELECTRONIC CONTROLLER - MAIN	1	ACXA73C0443	ACXA73C0444	O
	14	PARTICULAR PIECE - TERMINAL	1	CWD933137A	←	
	15	ELECTRONIC CO. (INDICATOR & RECEIVER)	1	ACXA73-02450	←	O
	16	SENSOR COMPLETE	1	CWA50C2800	←	O
	23	CONTROL BOARD TOP COVER	1	ACXH13-00240	←	
	24	INDICATOR HOLDER	1	CWD933406	←	
	25	CONTROL BOARD FRONT COVER CO.	1	CWH13C1333	←	
	26	DISCHARGE GRILLE COMPLETE	1	CWE20C3495	←	
	27	BACK COVER CHASSIS	1	CWD933233B	←	
	28	FULCRUM	1	CWH621131	←	
	29	VERTICAL VANE	8	CWE241374	←	
	30	CONNECTING BAR (R)	2	CWE261251	←	
	33	AIR SWING MOTOR (BIG H. VANE)	1	CWA981264	←	O
	34	CAP - DRAIN TRAY	1	CWH521259	←	
	35	HORIZONTAL VANE CO. (BIG)	1	CWE24C1385	←	
	36	REMOTE CONTROL COMPLETE	1	CWA75C4643	←	O
	37	FRONT GRILLE COMPLETE	1	ACXE10C00710	←	O
	38	INTAKE GRILLE COMPLETE	1	CWE22C1861	←	
	39	GRILLE DOOR COMPLETE	1	CWE14C1131	←	
	40	AIR FILTER	2	CWD001279	←	O
	41	SCREW - FRONT GRILLE	2	XTT4+16CFJ	←	
	42	CAP - FRONT GRILLE	2	CWH521227	←	
	43	DRAIN HOSE	1	CWH851173	←	
	44	INSTALLATION PLATE	1	CWH361134	←	
	45	BAG COMPLETE - INSTALLATION SCREW	1	CWH82C1705	←	
	46	OPERATING INSTRUCTION	1	ACXF55-00750	←	
	47	INSTALLATION INSTRUCTION	1	ACXF60-01080	←	
	48	INSTALLATION INSTRUCTION	1	ACXF60-01090	←	
	55	BAG COMPLETE (TUBE CONNECTOR)	1	CWH82C2030	←	

(Note)

- All parts are supplied from PHAAM, Malaysia (Vendor Code: 00029488).
- "O" marked parts are recommended to be kept in stock.

21.1.2 CS-RE18SKUA CS-RE24SKUA

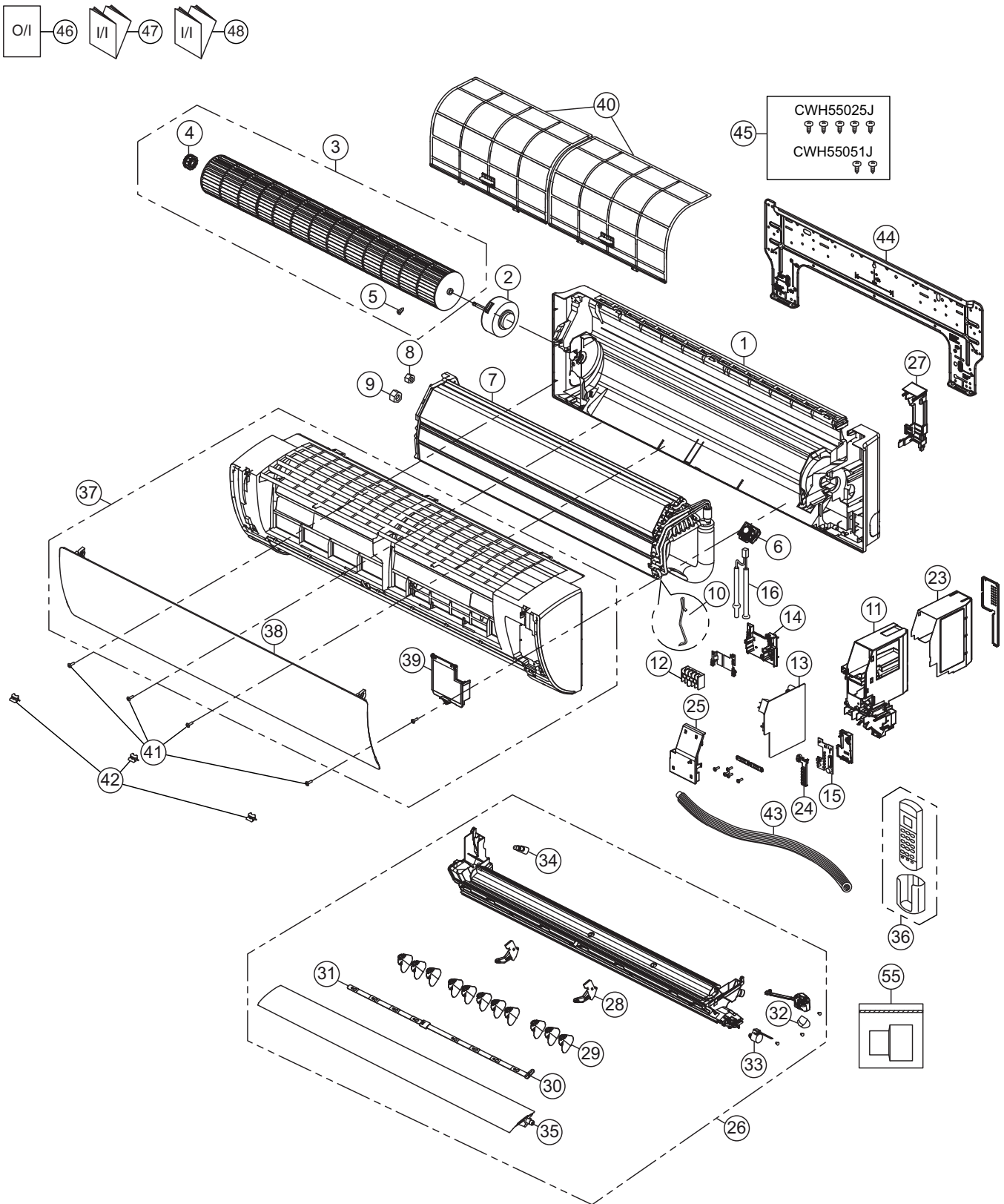

Note
 The above exploded view is for the purpose of parts disassembly and replacement.
 The non-numbered parts are not kept as standard service parts.

SAFETY	REF. NO.	PART NAME & DESCRIPTION	QTY.	CS-RE18SKUA	CS-RE24SKUA	REMARK
	1	CHASSIS COMPLETE	1	CWD50C1637	←	
⚠	2	FAN MOTOR	1	L6CBYYYYL0056	←	O
	3	CROSS - FLOW FAN COMPLETE	1	CWH02C1077	←	
	4	BEARING ASSY	1	CWH64K1010	←	O
	5	SCREW - CROSS - FLOW FAN	1	CWH551146	←	
	6	PARTICULAR PIECE	1	CWD933067	←	
	7	EVAPORATOR	1	ACXB30C01100	CWB30C3967	
	8	FLARE NUT (LIQUID)	1	CWT251048	←	
	9	FLARE NUT (GAS)	1	CWT251032	CWT251033	
	10	CLIP FOR SENSOR	1	CWH32142	←	
	11	CONTROL BOARD CASING	1	CWH102605A	←	
⚠	12	TERMINAL BOARD COMPLETE	1	CWA28C2357	←	O
⚠	13	ELECTRONIC CONTROLLER - MAIN	1	ACXA73C0445	ACXA73C0446	O
	14	PARTICULAR PIECE - TERMINAL	1	CWD933137A	←	
⚠	15	ELECTRONIC CO. (INDICATOR & RECEIVER)	1	ACXA73-02450	←	O
	16	SENSOR COMPLETE	1	CWA50C3228	←	O
	23	CONTROL BOARD TOP COVER	1	ACXH13-00240	←	
	24	INDICATOR HOLDER	1	CWD933406	←	
	25	CONTROL BOARD FRONT COVER CO.	1	CWH13C1333	←	
	26	DISCHARGE GRILLE COMPLETE	1	CWE20C3496	←	
	27	BACK COVER CHASSIS	1	CWD933031B	←	
	28	FULCRUM	2	CWH621138	←	
	29	VERTICAL VANE	11	CWE241374	←	
	30	CONNECTING BAR (R)	1	CWE261257	←	
	31	CONNECTING BAR (L)	1	CWE261258	←	
⚠	32	AIR SWING MOTOR ASS'Y (VERTICAL VANE)	1	CWA98K1024	←	O
⚠	33	AIR SWING MOTOR (BIG H. VANE)	1	CWA981241	←	O
	34	CAP - DRAIN TRAY	1	CWH521259	←	
	35	HORIZONTAL VANE CO.(BIG)	1	CWE24C1392	←	
	36	REMOTE CONTROL COMPLETE	1	ACXA75C00310	←	O
	37	FRONT GRILLE COMPLETE	1	ACXE10C00720	←	O
	38	INTAKE GRILLE COMPLETE	1	CWE22C1888	←	
	39	GRILLE DOOR COMPLETE	1	CWE14C1131	←	
	40	AIR FILTER	2	CWD001283	←	O
	41	SCREW - FRONT GRILLE	3	XTT4+16CFJ	←	
	42	CAP - FRONT GRILLE	3	CWH521227	←	
	43	DRAIN HOSE	1	CWH851173	←	
	44	INSTALLATION PLATE	1	CWH361098	←	
	45	BAG COMPLETE - INSTALLATION SCREW	1	CWH82C1705	←	
	46	OPERATING INSTRUCTION	1	ACXF55-00760	←	
	47	INSTALLATION INSTRUCTION	1	ACXF60-01100	←	
	48	INSTALLATION INSTRUCTION	1	ACXF60-01110	←	
	55	BAG COMPLETE (TUBE CONNECTOR)	1	CWH82C2030	←	

(Note)

- All parts are supplied from PAPAMY, Malaysia (Vendor Code: 00029488).
- "O" marked parts are recommended to be kept in stock.

21.2 Outdoor Unit

21.2.1 CU-RE9SKUA CU-RE12SKUA

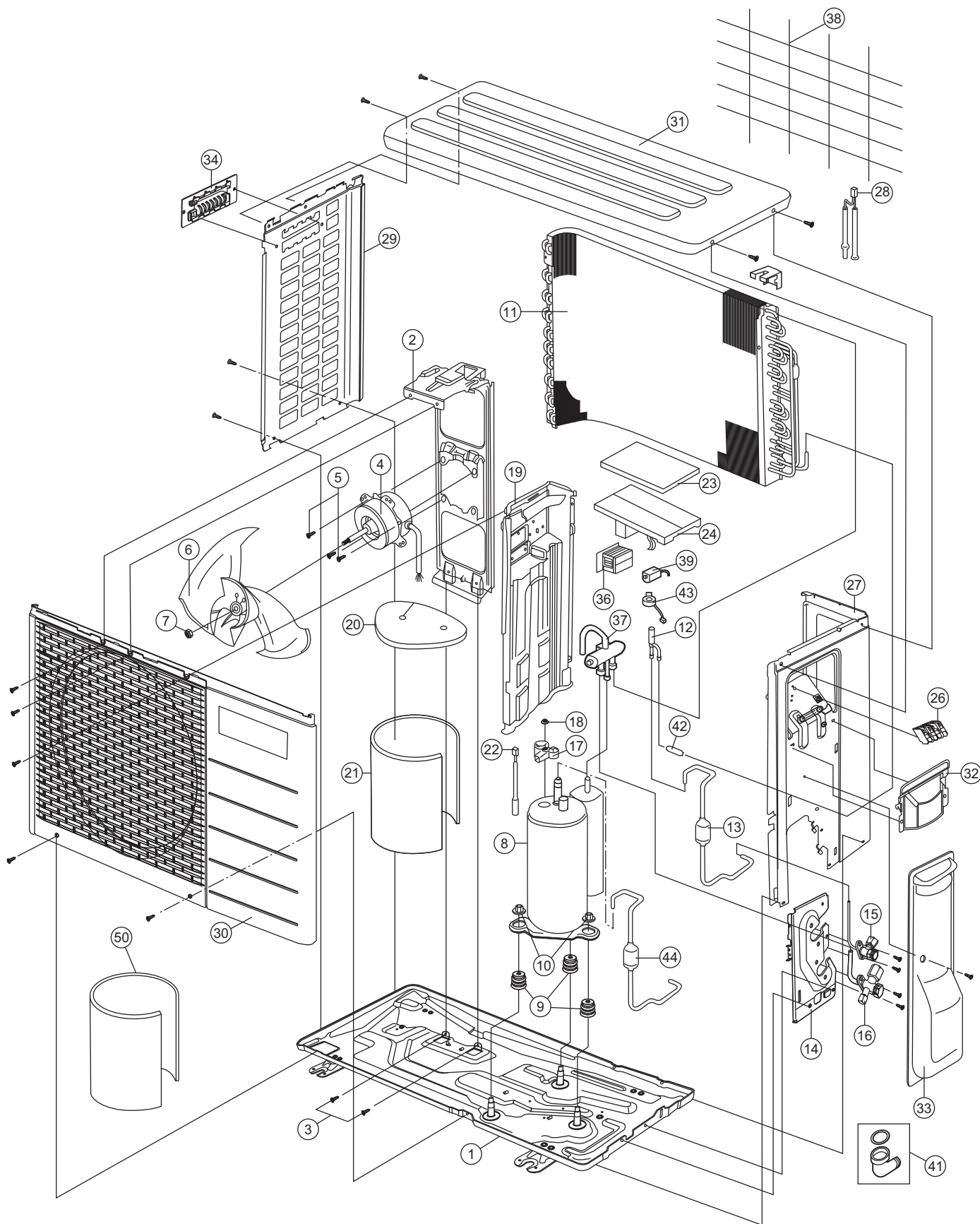

Note
The above exploded view is for the purpose of parts disassembly and replacement.
The non-numbered parts are not kept as standard service parts.

SAFETY	REF. NO.	PART NAME & DESCRIPTION	QTY.	CU-RE9SKUA	CU-RE12SKUA	REMARK
	1	CHASSIS COMPLETE	1	CWD50K2081A	←	
	2	FAN MOTOR BRACKET	1	CWD541089	←	
	3	SCREW - FAN MOTOR BRACKET	3	CWH551217	←	
⚠	4	FAN MOTOR	1	L6CAYYYL0067	←	O
	5	SCREW - FAN MOTOR MOUNT	4	CWH55252J	←	
	6	PROPELLER FAN ASSY	1	CWH03K1100	←	
	7	NUT - PROPELLER FAN	1	CWH56053J	←	
⚠	8	COMPRESSOR	1	5RS102XBC21	←	O
	9	ANTI - VIBRATION BUSHING	3	CWH50077	←	
	10	NUT - COMPRESSOR MOUNT	3	CWH561096	←	
	11	CONDENSER	1	ACXB32C00590	←	
	12	EXPANSION VALVE	1	CWB051078	←	
	13	DISCHARGE MUFFLER (EXP.VALVE)	1	CWB121021	←	
	14	HOLDER COUPLING	1	CWH351231A	←	
	15	2-WAYS VALVE (LIQUID)	1	CWB021180J	←	O
	16	3-WAY VALVE (GAS)	1	CWB011374	CWB011367	O
	17	TERMINAL COVER	1	CWH171039A	←	
	18	NUT - TERMINAL COVER	1	CWH7080300J	←	
	19	SOUND PROOF BOARD	1	CWH151172A	←	
	20	SOUND PROOF MATERIAL (TOP)	1	CWG302656	←	
	21	SOUND PROOF MATERIAL (BODY)	1	CWG302948	←	
	22	SENSOR CO - COMP TEMP	1	CWA50C2340	←	O
	23	CONTROL BOARD COVER - TOP	1	CWH131264	←	
⚠	24	ELECTRONIC CONTROLLER - MAIN	1	ACXA73C04490R	ACXA73C04500R	O
⚠	26	TERMINAL BOARD ASSY	1	CWA28K1154	←	O
	27	CABINET SIDE PLATE CO.	1	CWE04C1226	←	
	28	SENSOR CO - AIR TEMP AND PIPE TEMP	1	CWA50C2710	←	O
	29	CABINET SIDE PLATE	1	CWE041492A	←	
	30	CABINET FRONT PLATE CO.	1	CWE06C1142	←	
	31	CABINET TOP PLATE	1	CWE031018A	←	
	32	CONTROL BOARD COVER	1	CWH131301	←	
	33	CONTROL BOARD COVER - COMPLETE	1	CWH13C1345	←	
	34	HANDLE	1	CWE161010	←	
	36	REACTOR	1	G0C103J00013	←	
	37	4-WAYS VALVE	1	CWB001058	←	
	38	WIRE NET	1	CWD041161A	←	
⚠	39	V-COIL COMPLETE (4 WAY VALVE)	1	ACXA43C00270	←	O
	41	BAG-COMPLETE (L-TUBE)	1	CWG87C900	←	
	42	STRAINER	1	CWB111061	←	
⚠	43	V-COIL COMPLETE (EXPANSION VALVE)	1	ACXA43C00320	←	O
	44	DISCHARGE MUFFLER (4 W. VALVE)	1	CWB121047	←	
	50	SOUND PROOF MATERIAL	1	CWG302292	←	

(Note)

- All parts are supplied from PHAAM, Malaysia (Vendor Code: 00029488).
- "O" marked parts are recommended to be kept in stock.

21.2.2 CU-RE18SKUA CU-RE24SKUA

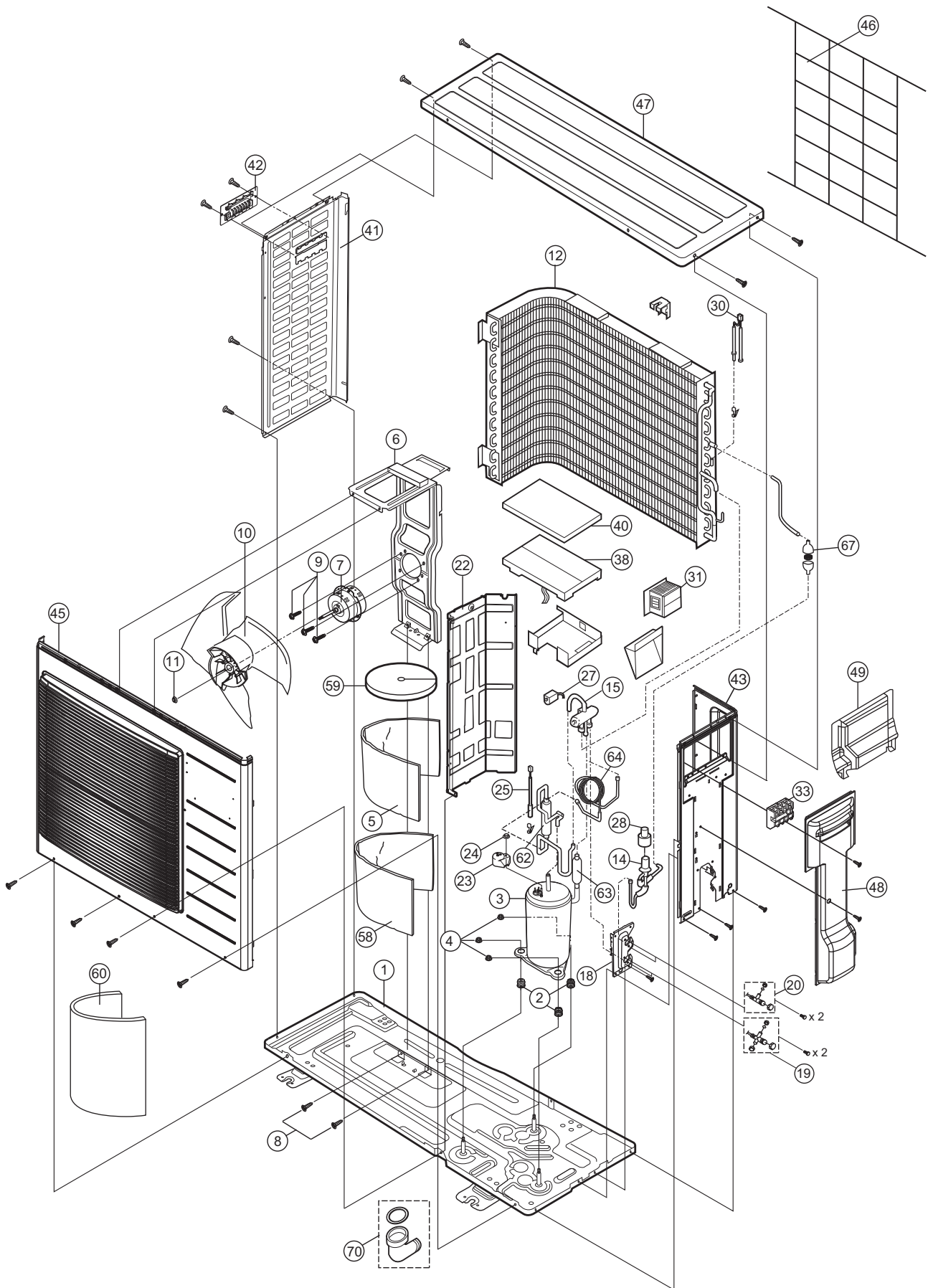

Note
 The above exploded view is for the purpose of parts disassembly and replacement.
 The non-numbered parts are not kept as standard service parts.

SAFETY	REF. NO.	PART NAME & DESCRIPTION	QTY.	CU-RE18SKUA	CU-RE24SKUA	REMARK
	1	CHASSIS COMPLETE	1	CWD52K1347A	←	
	2	ANTI - VIBRATION BUSHING	3	CWH50077	←	
⚠	3	COMPRESSOR	1	5RD132XBA21	←	O
	4	NUT - COMPRESSOR MOUNT	3	CWH561096	←	
	5	SOUND PROOF MATERIAL (BODY)	1	CWG302744	←	
	6	FAN MOTOR BRACKET	1	CWD541153	←	
⚠	7	FAN MOTOR	1	ARW8407AC	←	O
	8	SCREW - FAN MOTOR BRACKET	3	CWH551217	←	
	9	SCREW - FAN MOTOR MOUNT	4	CWH551106J	←	
	10	PROPELLER FAN ASSY	1	CWH03K1065	←	
	11	NUT - PROPELLER FAN	1	CWH56053J	←	
	12	CONDENSER	1	ACXB32C00610	←	
	14	EXPANSION VALVE	1	CWB051078	←	
	15	4-WAYS VALVE	1	CWB001057	←	
	18	HOLDER COUPLING	1	CWH351228A	←	
	19	3-WAY VALVE (GAS)	1	CWB011338	CWB011363	O
	20	2-WAYS VALVE (LIQUID)	1	CWB021400	←	O
	22	SOUND PROOF BOARD	1	CWH151379	←	
	23	TERMINAL COVER	1	CWH171039A	←	
	24	NUT - TERMINAL COVER	1	CWH7080300J	←	
	25	SENSOR CO-COMP TEMP	1	CWA50C2343	←	O
⚠	27	V-COIL COMPLETE (4 WAY VALVE)	1	CWA43C2392	←	O
⚠	28	V-COIL COMPLETE (EXP.VALVE)	1	ACXA43C00320	←	O
	30	SENSOR CO-AIR TEMP AND PIPE TEMP	1	CWA50C2710	←	O
	31	REACTOR	1	G0C203J00003	←	
	33	TERMINAL BOARD ASSY	1	CWA28K1154	←	O
⚠	38	ELECTRONIC CONTROLLER - MAIN	1	ACXA73C04510R	ACXA73C04520R	O
	40	CONTROL BOARD COVER - TOP	1	CWH131333	←	
	41	CABINET SIDE PLATE (LEFT)	1	CWE041733A	←	
	42	HANDLE	1	CWE161010	←	
	43	CABINET SIDE PLATE CO.	1	CWE041732A	←	
	45	CABINET FRONT PLATE CO.	1	CWE06K1101	←	
	46	WIRE NET	1	CWD041155A	←	
	47	CABINET TOP PLATE	1	CWE031131A	←	
	48	CONTROL BOARD COVER-COMPLETE	1	CWH13C1308	←	
	49	CONTROL BOARD COVER	1	CWH131409	←	
	58	SOUND PROOF MATERIAL	1	CWG302632	CWG302638	
	59	SOUND PROOF MATERIAL (TOP)	1	CWG302630	←	
	60	SOUND PROOF MATERIAL	1	CWG302636	CWG302600	
⚠	62	DISCHARGE MUFFLER (4 W. VALVE)	1	CWB121047	-	
	63	OIL SEPARATER ASS'Y	-	-	ACXB16K00010	
	64	CAPILLARY TUBE A'SSY	-	-	CWB15K1487	

SAFETY	REF. NO.	PART NAME & DESCRIPTION	QTY.	CU-RE18SKUA	CU-RE24SKUA	REMARK
	67	STRAINER	1	CWB111076	←	
	70	BAG - COMPLETE (L-TUBE)	1	CWG87C900	←	

(Note)

- All parts are supplied from PAPAMY, Malaysia (Vendor Code: 00029488).
- "O" marked parts are recommended to be kept in stock.