

## Submittal Data Sheet

### CS-MXZ5AKUA

### Mini Split Indoor Unit

Job Name: \_\_\_\_\_  
 Location: \_\_\_\_\_  
 Engineer: \_\_\_\_\_  
 Submitted to: \_\_\_\_\_  
 Submitted by: \_\_\_\_\_  
 Reference: \_\_\_\_\_

Approval: \_\_\_\_\_  
 Date: \_\_\_\_\_  
 Construction: \_\_\_\_\_  
 Unit #: \_\_\_\_\_  
 Drawing #: \_\_\_\_\_

General Data	
Power Supply (V/PH/Hz)	208-230 / 1 / 60

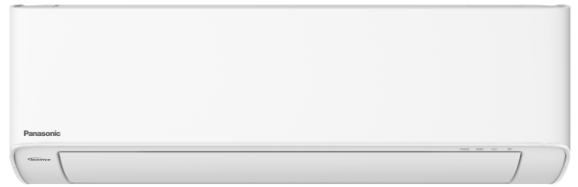

Intertek



Indoor Unit	
Fan Type	Crossflow Fan
Motor Type, No. of Poles	DC Motor, 8 poles
No. Speeds	Variable speed
RPM (Cool / Heat), High	1040 / 1040
No. Motors / Input Power (W)	1 / 47
CFM (QLo / Lo / Me / Hi / SHi) Cooling	150 / 214 / 305 / 405 / 427
CFM (QLo / Lo / Me / Hi / SHi) Heating	150 / 214 / 286 / 405 / 427
Operating Sound-Hi/Me/Lo (dB-A) Cool	42 / 27 / 21
Operating Sound-Hi/Me/Lo (dB-A) Heat	43 / 31 / 21
Coil Type	Aluminum (Pre Coat)
Fin Type - Pipe Type	Slit Fin - Inner Rifled
Row x Stage x FPI	2 x 17 x 21
Size (WxHxL)	25-3/8 x 14-1/16 x 1
Tube Size (in.)	7-1/4"
Drain Connection Size (in.)	5/8"
<b>Refrigerant</b>	R32
Refrigerant Tubing Connections	Flare
Line Length, Max (ft.)	82
Elevation Difference, Max (ft.)	49.2
Line Size (in. O.D. Discharge)	1/4"
Line Size (in. O.D. Suction)	3/8"
<b>Dimensions (HxWxD)</b>	
Indoor Unit (Uncrated) (in.)	11-5/8 x 34-9/32 x 9-1/32
<b>Weight (lbs.)</b>	
Indoor Net	22 lbs

Features	
Controls	Microprocessor
Remote Controller	LCD Wireless Type included
Wired Remote Controller	Optional CZ-RD517C
Temperature Control	IC Thermistor
Timer	Single Event Daily ON/OFF Timer
Quiet mode	Included
High Power Mode	Included
Air Louver, Horizontal	Step, Swing
Air Louver, Vertical	Automatic, Sweep, Step
Power Failure Automatic Restart	Built-In
Heating/Cooling Automatic Changeover	Built-In
Self-Diagnosis	Built-In
Air Filter	Washable, One-touch

Operating Range	
Cooling (Max)	89.6°F DB / 73.4°F WB
Cooling (Min)	60.8°F DB / 51.8°F WB
Heating (Max)	86.0°F DB
Heating (Min)	60.8°F DB

## Indoor Dimensions

<Top View>

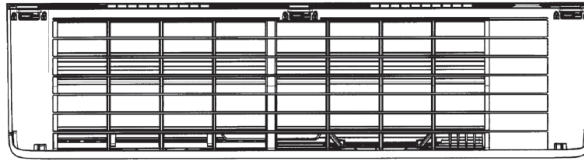

<Side View>

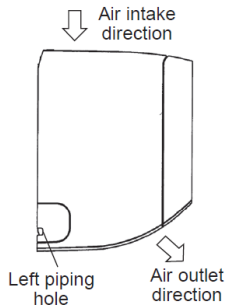

<Front View>

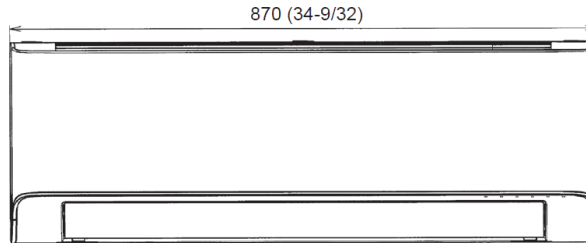

<Side View>

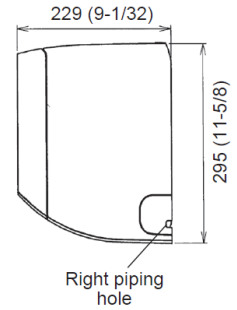

<Bottom View>

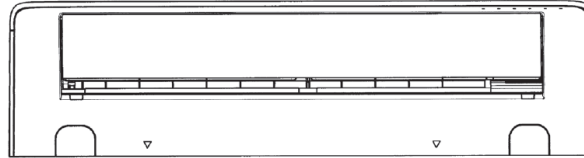

<Remote Control>

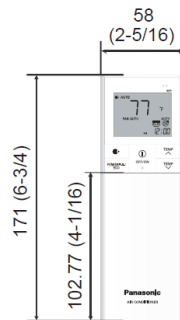

<Rear View>

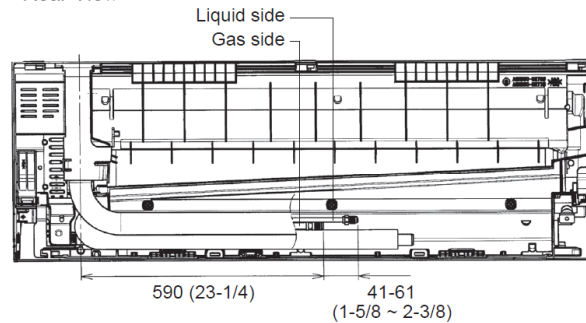

<Remote Control Holder>

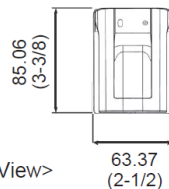

Relative position between the indoor unit and the installation plate <Front View>

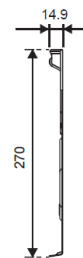
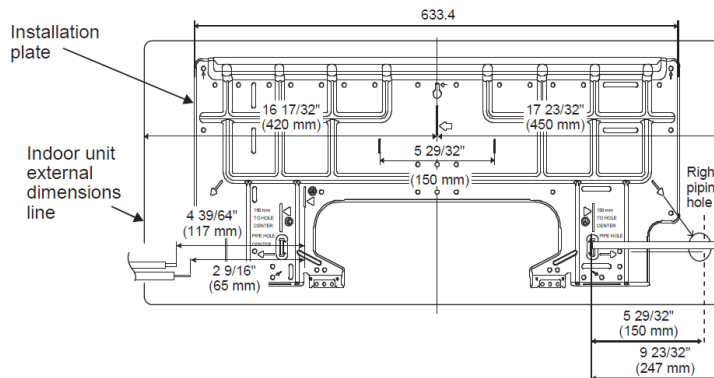

### Panasonic Canada

5770 Ambler Drive  
Mississauga, ON L4W 2T3

<https://na.panasonic.ca/indoor-air-quality/hvac>

breathe well

The Only Complete Air Quality Solution™