

# Submittal Data Sheet

# Panasonic

Series Name: Regular Heat AHU Series  
 Model Number: CS-HM48BAHU/CU-M48BAHU

## AIR HANDLER HEAT PUMP SYSTEM

Location:	Approval:
Engineer:	Date:
Submitted to:	Construction:
Submitted by:	Unit #:
Reference:	Drawing #:



## INDOOR SPECIFICATION

Indoor Air Flow	1600.99 / 1471.50 / 1283.15 /	
Indoor Noise Level (Turbo/H/M/L)	N/A/53/50/44/N/A	
Dimension (WxDxH)	inch	21.02 x 24.49 x 52.99
	mm	534.0x622.0x1346.0
Package (WxDxH)	inch	27.95 x 26.77 x 56.50
	mm	710x680x1435
Net/Gross	lbs	162.92/190.92
Weight	kg	73.9/86.6

## OUTDOOR SPECIFICATION

Compressor Type	ROTARY	
Compressor Model	MTH550UKPC8FU	
Refrigerant	R454B	
Refrigerant Oil Charge(mL)	1800	
Refrigerant Oil	HAF68D1C	
Outdoor Air Flow (Max) (CFM)	3037.1	
Outdoor Noise Level (dBA)	65	
Dimension (WxDxH)	inch	38.58 x 16.34 x 38.39
	mm	980.0x415.0x975.0
Package (WxDxH)	inch	45.08 x 19.68 x 42.52
	mm	1145x500x1080
Net/Gross	lbs	192.90/224.21
Weight	kg	87.5/101.7

## EFFICIENCY

Cooling		Heating	
SEER2	16.0	HSPF2-4	8.5
EER2	10.0	COP	3.45

## PERFORMANCE of Cooling

Cooling (Btu/hr)	
Rated Capacity	48000
Min/Max Capacity	16600-49900
Moisture Removal(L/h)	5.29
Standard Operating Range(°F)	-13~122(-25~50)
Rated Cooling Conditions:	Indoor: 80°F DB/67°F WB Outdoor: 95°F DB/75°F WB

## PERFORMANCE of Heating

Heating (Btu/hr)	
1. @ 47°F Rated	48000
2. @ 47°F Min/Max Capacity	15300-49500

## ELECTRICAL

Indoor Power Supply	115/208/230V,60Hz,1Ph
Indoor MCA 115V/(208/230V)	14.5/11.0
Indoor MOP	15
Outdoor Power Supply	208/230V,60Hz,1Ph
Outdoor MCA	36
Outdoor MOP	40
Communication Wiring	AWG 20-2
Compressor RLA	27
Outdoor Fan Motor RLA	2
Outdoor Fan Motor W	250
Indoor Fan Motor RLA	7.8
Indoor Fan Motor W	750
System Power Input @ Cooling (W)	4800(1400 ~ 5350)
System Power Input @ Heating (W)	4085(1025 ~ 4650)
MCA: Min. circuit amps (A)	CP: Max. over current protector
RLA: Rated load amps (A)	W: Fan motor rated output (W)

<b>3. @ 17°F Rated</b>	32400
<b>4. @ 5°F Rated: Capacity / COI</b>	38000/1.85
<b>5. @ 5°F Max: Capacity</b>	38000
<b>Standard Operating Range(°F)</b>	-13~75(-25~24)
1. Rated Heating Conditions:	Indoor: 70°F DB/60°F WB Outdoor: 47°F DB/43°F WB
2. Rated Heating Conditions:	Indoor: 70°F DB/60°F WB Outdoor: 17°F DB/15°F WB
3. Heating Conditions, Compre	Indoor: 70°F DB/60°F WB
Operating at Max. Frequency	Outdoor: 5°F DB/5°F WB

PIPING	
Throttle type(Indoor)	EXV
Throttle type(Outdoor)	EXV
Liquid Size	9.52mm(3/8in)
Gas Size	19mm(3/4in)
Max. Piping Length(ft/m)	246(75)
Max. Height Difference(ft/m)	98.4(30)
Max. Pre-charged Length(ft/m)	24.6(7.5)
Refrigerant Pre-charged Additional Charge or	134.04(3.8)
Refrigerant((oz/ft)/(g/m))	0.7(65)
Connection Method	Flared

# INDOOR UNIT DIMENSIONS

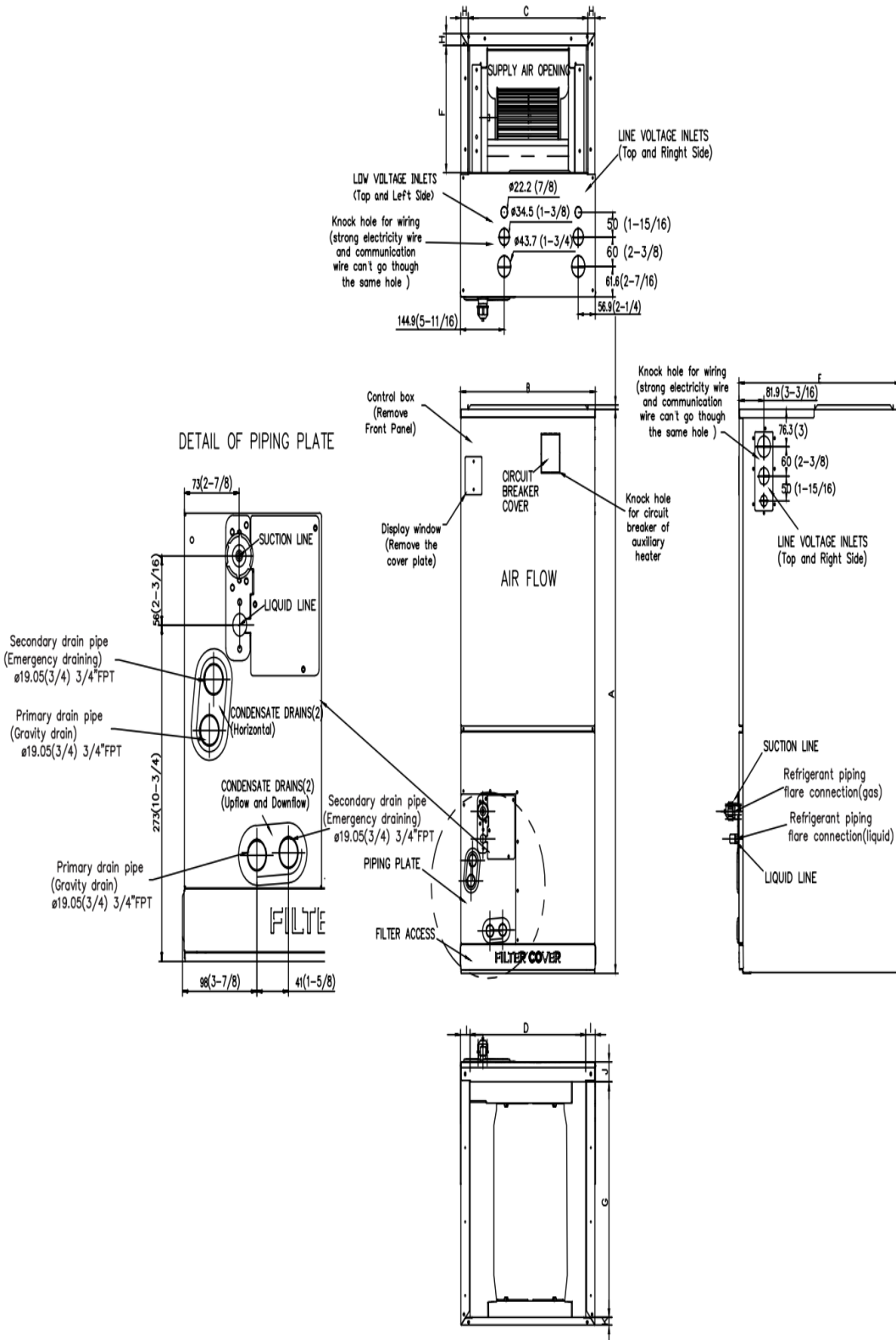

Dimensions \ Model		18k/24k		30k/36k		48k/60k	
		inch	mm	inch	mm	inch	mm
A	Model Height	45	1143	49	1245	53	1346
B	Model Width	17-1/2	445	21	534	24-1/2	622
C	Supply Air Opening Width	15-5/8	397	19-1/8	486	22-5/8	575
D	Return Air Opening Width	15-1/8	384	18-5/8	473	22-1/8	562
E	Model Depth	21	534	21	534	21	534
F	Supply Air Opening Depth	10-1/4	260	10-1/4	260	10-1/4	260
G	Return Air Opening Depth	18-3/4	476	18-3/4	476	18-3/4	476
H	Supply Air Opening Clearance	15/16	24	15/16	24	15/16	24
I	Return Air Opening Side Clearance	1-1/4	32	1-1/4	32	1-1/8	28
J	Return Air Opening Front Clearance	1-1/2	38	1-5/8	41	1-5/8	41
K	Return Air Opening Back Clearance	5/8	16	5/8	16	3/4	19

## OUTDOOR UNIT DIMENSIONS

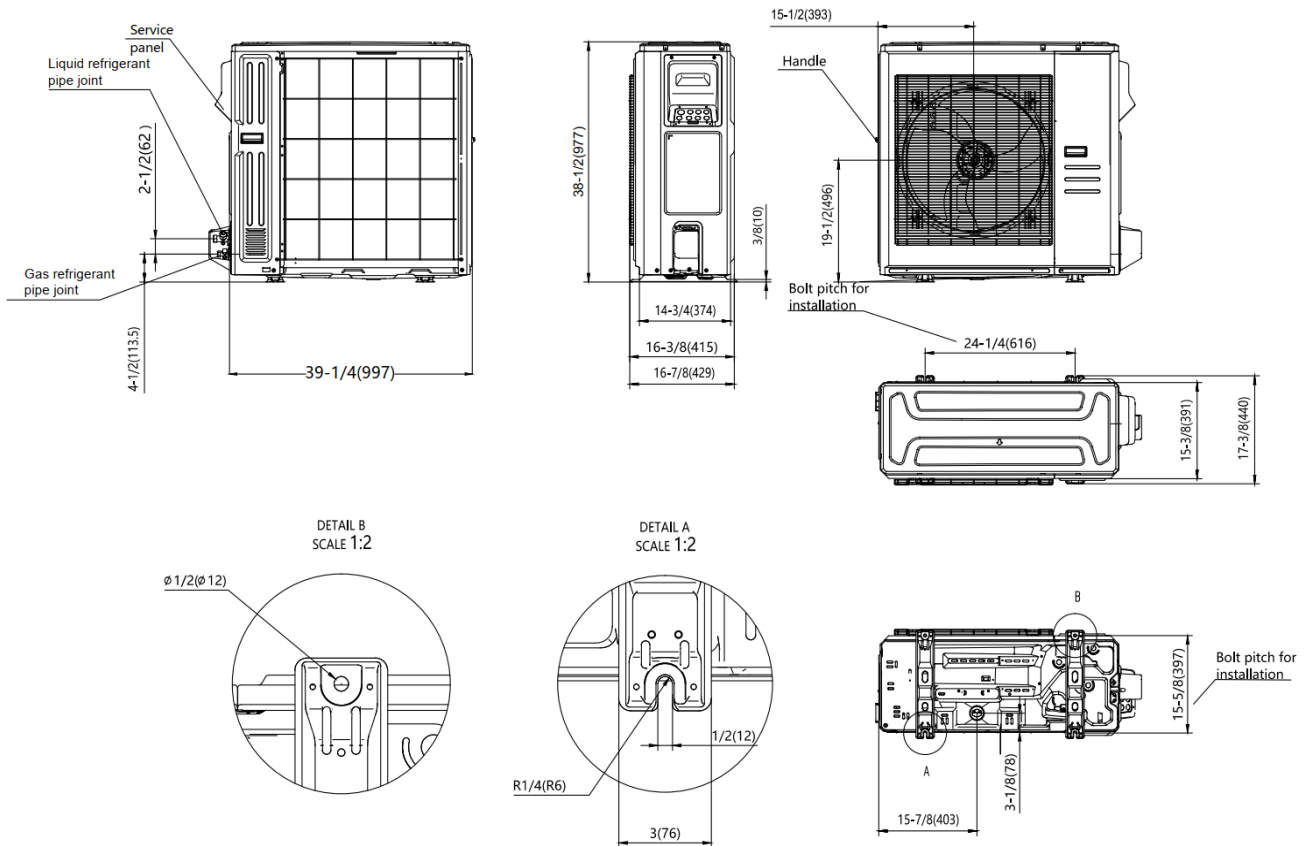

## INSTALLATION INSTRUCTIONS FOR OUTDOOR UNIT

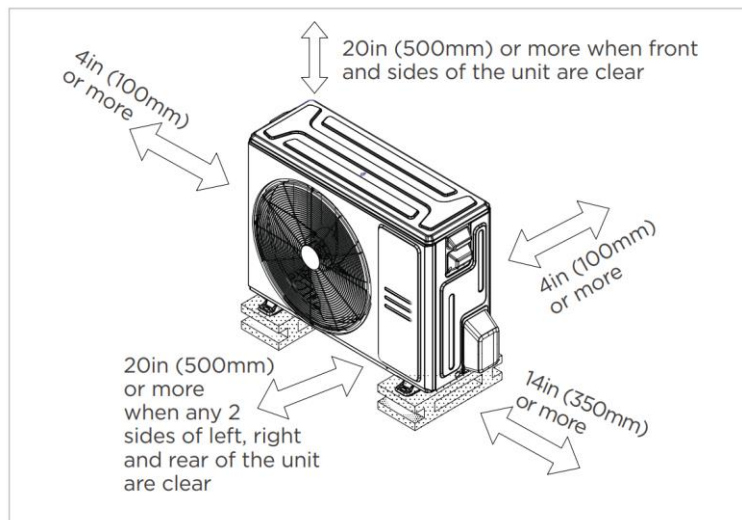

Meets all spatial requirements shown in Installation Clearance Requirements above.

## FAN PERFORMANCE FOR INDOOR UNIT

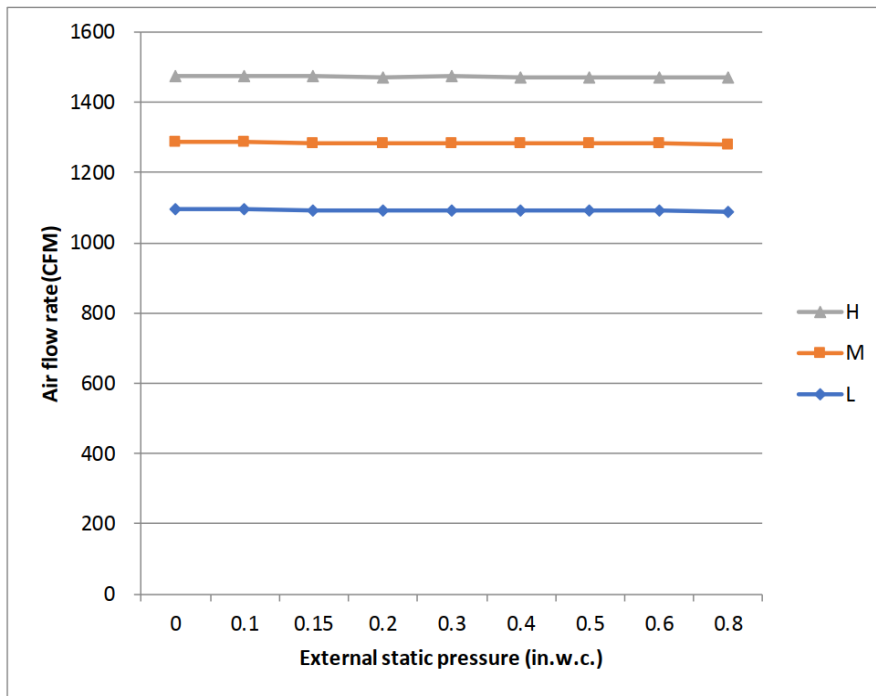

## FEATURES

- Multi-position installation: horizontal(left or right), vertical( up or down)
- Aluminum Coil
- Constantly Air Flow system up to 0.80 In.W.G
- 1 inch R4.2 fiberglass free insulation reduces condensation and boosts efficiency(optional)
- Optional Auxiliary heat kit up to 25kW
- Easy Maintenance
- Multiple control options available:
  - Two way communication wired controller:120N(X6)
  - Two way communication wired controller with built-in WiFi:120N(X6W)
  - Wireless remote controller
  - Third-Party 24V Thermostat
- Adaptive Control System
- High efficiency up to 18.8 SEER2, 11 EER2, 9.7 HSPF2
- Chassis heater and crankcase heater equipped as standard