

Panasonic

Air conditioner

Installation Instruction

MODEL NO. :-
CS-XE9, XE12, XE15WKUA Series.
CU-XE9, XE12, XE15WKUA Series.

Required tools for Installation Works

1 Phillips screw driver	7 Reamer	13 Multimeter
2 Level gauge	8 Knife	14 Torque wrench
3 Electric drill, hole core drill (ø2 3/4" (ø70 mm))	9 Gas leak detector	15 Vacuum pump
4 Hexagonal wrench (1/2" (4 mm))	10 Measuring tape	16 Digital Microm Gage
5 Spanner	11 Thermometer	
6 Pipe cutter	12 Megameter	

SAFETY PRECAUTIONS

- Read the following "SAFETY PRECAUTIONS" carefully before installation.
- Electrical work must be installed by a licensed electrician. Be sure to use the correct rating of the power plug and main circuit for the model to be installed. The caution items listed below are important contents related to safety. The meaning of each indication used is as below. Incorrect installation due to ignoring of the instruction will cause harm or damage, and the seriousness is classified by the following indications.

- WARNING** This indication shows the possibility of causing death or serious injury.
- CAUTION** This indication shows the possibility of causing injury or damage to properties only.
- Items to be followed are classified by the symbols:
 - Symbol with white background denotes item that is PROHIBITED.
 - Symbol with dark background denotes item that must be carried out.

- Carry out test running to confirm that abnormal occurs after the installation. Then, explain to user the operation, care and maintenance as stated in instructions. Please remind the customer to keep the operating instructions for future reference.
- WARNING**
 - Do not install outdoor unit near handrail of veranda. When installing air-conditioner unit on veranda of a high rise building, child may climb up to outdoor unit and cross over the handrail causing an accident.
 - Do not use unspecified cord, modified cord, joint cord or extension cord for power supply cord. Do not share the single outlet with other electrical appliances. Poor contact, poor insulation or over current will cause electrical shock or fire.
 - Do not tie up the power supply cord into a bundle by band. Abnormal temperature rise on power supply cord may happen.
 - Do not insert your fingers or other objects into the unit, high speed rotating fan may cause injury.
 - Do not sit or step on the unit, you may fall down accidentally.
 - Keep plastic bag (packaging material) away from small children, it may cling to nose and mouth and prevent breathing.
 - When installing or relocating air conditioner, do not let any substance other than the specified refrigerant, gas, air mix into refrigeration cycle (piping). Mixing of air will cause abnormal high pressure in refrigeration cycle and result in explosion, injury etc.
 - Do not add or replace refrigerant other than specified type. It may cause product damage, burst and injury etc.

- For R32/R410A model, use piping, flare nut and tools which is specified for R32/R410A refrigerant. Using of existing (R22) piping, flare nut and tools may cause abnormally high pressure in refrigeration cycle (piping), and possibly result in explosion and injury. For R32 and R410A, the same flare nut on the outdoor unit side and pipe can be used.
- Since the working pressure for R32/R410A is higher than that of refrigerant R22 model, replacing conventional piping and flare nuts on the outdoor unit side are recommended. If reuse piping is unavoidable, refer to instruction "IN CASE OF REUSING EXISTING REFRIGERANT PIPING".
- Thickness for copper pipes used with R32/R410A must be more than 1/32" (0.8 mm). Never use copper pipes thinner than 1/32" (0.8 mm).
- It is desirable that the amount of residual oil is less than 0.0004 oz (0.02 kg) (0.1 g).
- Engage authorized dealer or specialist for installation. If installation done by the user is incorrect, it will cause water leakage, electrical shock or fire.
- Install according to this installation instructions strictly. If installation is defective, it will cause water leakage, electrical shock or fire.
- Use the attached accessories parts and specified parts for installation. Otherwise, it will cause the set to fall, water leakage, fire or electrical shock.
- Install at a strong and firm location which is able to withstand the set's weight. If the strength is not enough or installation is not properly done, the set will drop and cause injury.
- For installation work, follow all electrical, building, plumbing, local codes, regulations and these installation instructions. If electrical circuit capacity is not enough or a defect is found in electrical work, it will cause electrical shock or fire.
- Do not use spliced wires for indoor / outdoor connection cable. Use the specified indoor / outdoor connection cable, refer to instruction "INDOOR/OUTDOOR UNIT ELECTRICAL WIRING" and connect tightly for indoor/outdoor connection. Clamp the cable so that no external force will have impact on the terminal. If connection or wiring is not perfect, it will cause heat or fire at the connection.
- Wire routing must be properly arranged so that control board cover is fixed properly. If control board cover is not fixed perfectly, it will cause fire or electrical shock.
- This equipment must be installed with an Earth Leakage Circuit Breaker (ELCB) or Ground Fault Current Interrupter (GFCI) or Appliance Leakage Current Interrupter (ALCI) that has been certified by an NRTL Certified Testing Agency and that is suitable for the voltages and amperages involved. Otherwise, it may cause electrical shock and fire in case of equipment breakdown or insulation breakdown.
- During installation, install the refrigerant piping properly before running the compressor. Operation of compressor without fixing refrigeration piping and valves at opened condition will cause suck-in of air, abnormal high pressure in refrigeration cycle and result in explosion, injury etc.
- During pump down operation, stop the compressor before removing the refrigerant. Removal of refrigeration piping while compressor is operating and valves are opened will cause suck-in of air, abnormal high pressure in refrigeration cycle and result in explosion, injury etc.
- Tighten the flare nut with torque wrench according to specified method. If the flare nut is over-tightened, after a long period, the flare may break and cause refrigerant gas leakage.
- After completion of installation, confirm there is no leakage of refrigerant gas. It may generate toxic gas when the refrigerant comes into contact with fire.
- Ventilate if there is refrigerant gas leakage during operation. It may cause toxic gas when the refrigerant comes into contact with fire.
- This equipment must be properly earthed. Earth line must not be connected to gas pipe, water pipe, earth of lightning rod and telephone. Otherwise, it may cause electrical shock in case of equipment breakdown or insulation breakdown.

- CAUTION**
 - Do not install the unit at place where leakage of flammable gas may occur. In case gas leaks and accumulates at surrounding of the unit, it may cause fire.
 - Do not release refrigerant during piping work for installation, re-installation and during repairing a refrigeration parts. Take care of the liquid refrigerant, it may cause frostbite.
 - Do not install this appliance in a laundry room or other location where water may drip from the ceiling, etc.
 - Do not touch the sharp aluminium fin, sharp parts may cause injury.
 - Carry out drainage piping as mentioned in installation instructions. If drainage is not performed, water may enter the room and damage the furniture.

- Select an installation location which is easy for maintenance.
- Power supply connection to the room air conditioner. Power supply cord shall be UL listed or CSA approved 3 conductor with minimum AWG14 wires. Power supply point should be in an easily accessible place for power disconnection in case of emergency. Power source should be a dedicated circuit. The connection of this air conditioner to power supply is prohibited. Fix power supply connection to a circuit breaker for permanent connection. Use NRTL approved fuse or circuit breaker (rating refers to name plate) for permanent connection.
- Installation work. It may take two people to carry out the installation work.

- IMPORTANT**
 - This product has been designed and manufactured to meet ENERGY STAR® criteria for energy efficiency when matched with appropriate coil components. However, proper refrigerant charge is essential to achieve the rated capacity. Installation of this product should follow the manufacturer's instructions for refrigerant charging and air flow restrictions. Failure to conform may reduce energy efficiency and shorten equipment life.
 - Room Freeze Protection Function (RFP) is used in spaces that are unoccupied during the winter, for the purpose of protecting any equipment or appliances which may be destroyed as a result of freezing temperature. When the RFP is selected, the unit will operate the fan at high speed for 40P for 10 minutes. When the sensor detects that the room temperature has dropped below 46°F (8°C), the compressor and pump operation begins. When the room temperature reaches 50°F (10°C), the unit shuts off, then will repeat continuously if the temperature drops below 46°F (8°C) again.
 - The Room Freeze Protection Function (RFP) cannot be used unless the unit is energized and set into the RFP mode in the advent of a power failure this mode will not function. During the RFP mode, POWER OFF OPERATION AND FAN OFF OPERATION are all disabled. Please consult with your HVAC installer or professional for more details.

Attached accessories

No.	Accessories part	Qty.	Accessories part	Qty.
1	Installation plate	1	Remote control holder	1
2	Installation plate fixing screw	5	Remote control holder fixing screw	2
3	Remote Control	1	Drain hose adapter	1
4	Battery	2	Drain elbow	1
			Rubber cap	4

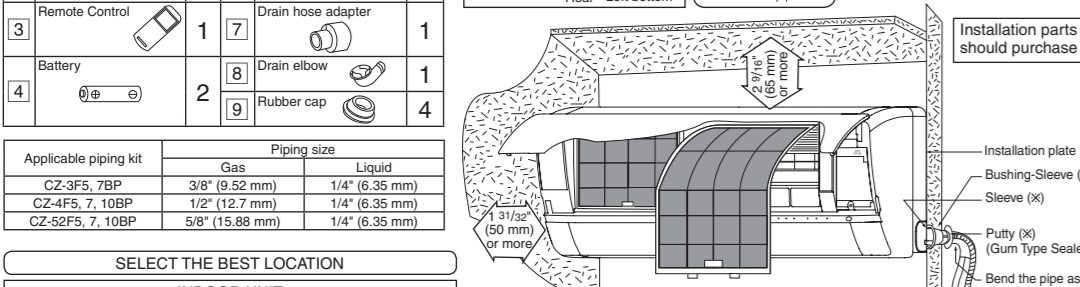

- #### SELECT THE BEST LOCATION
- ##### INDOOR UNIT
- Do not install the unit in excessive air areas such as kitchen, workshop and etc.
 - There should not be any heat source or steam near the unit.
 - Place where air circulation in the room is good.
 - Place where drainage can be easily done.
 - Place where noise prevention is taken into consideration.
 - Do not install the unit near the ceiling.
 - Ensure the spaces indicated by arrows from the ceiling, fence or other obstacles.
 - Indoor unit of this air conditioner that is installed in a height of at least 1.8 m.
- ##### OUTDOOR UNIT
- If an awning is built over the unit to prevent direct sunlight or rain, be careful that heat radiation from the condenser is not obstructed.
 - There should not be any animal or plant which could be affected by hot air discharged.
 - Keep the space indicated by arrows from wall, ceiling, fence or other obstacles.
 - Do not place any obstacles which may cause a short circuit of the discharged air.
 - If piping length over the piping length for additional gas, additional refrigerant should be added as shown in the table.
 - Recommended installation height for outdoor unit should be above the seasonal snow level.
 - Be careful not to locate outdoor unit directly under a roof line where falling snow or ice can cause damage or dripping water can increase ice accumulation and defrost cycles.

Model	Capacity (Btu/h)	Piping size Gas	Liquid	Std. Length	Max. Length	Min. Piping Length	Max. Piping Length	Additional Refrigerant	Piping length for test gas
XE9***	8500	3/8" (9.52 mm)	1/4" (6.35 mm)	24.6' (7.5 m)	49.2' (15 m)	9.8' (3 m)	85.6' (26 m)	0.2 oz (6 g)	24.6' (7.5 m)
XE12***	11500	1/2" (12.7 mm)	1/4" (6.35 mm)	24.6' (7.5 m)	49.2' (15 m)	9.8' (3 m)	85.6' (26 m)	0.2 oz (6 g)	24.6' (7.5 m)
XE15***	14200	1/2" (12.7 mm)	1/4" (6.35 mm)	24.6' (7.5 m)	49.2' (15 m)	9.8' (3 m)	85.6' (26 m)	0.2 oz (6 g)	24.6' (7.5 m)

Example: For XE9*** (10 m distance), the quantity of additional refrigerant should be 1.64 oz (37.5 g). (32.8 - 24.6) ft x 0.2 oz/ft = 1.64 oz. (10.7-7.5) m x 15 g/m = 37.5 g.

INDOOR UNIT

1 SELECT THE BEST LOCATION

(Refer to "Select the best location" section)

2 HOW TO FIX INSTALLATION PLATE

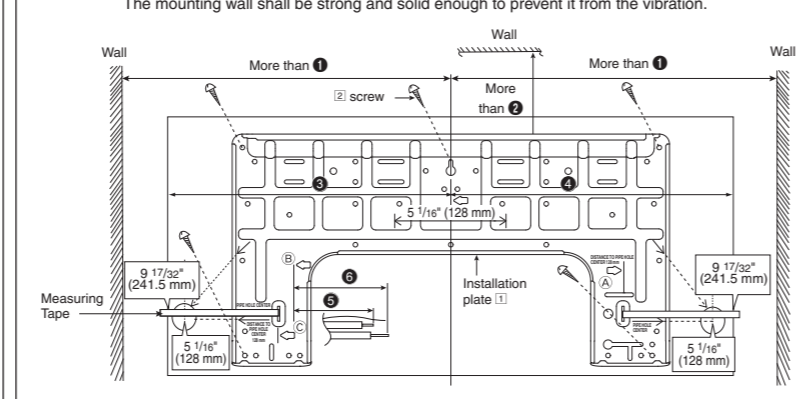

Model	Dimension				
	①	②	③	④	⑤
XE9***, XE12***, XE15***	19 3/32" (493 mm)	3 35/64" (90 mm)	17 9/32" (439 mm)	17" (433 mm)	1 11/16" (43 mm)

- The center of installation plate should be at more than ① at right and left of the wall. The distance from installation plate edge to ceiling should be more than ②. From installation plate left edge to unit's left side is ③. From installation plate right edge to unit's right is ④.
- ⑤ : For left side piping, piping connection for liquid should be about ⑤ from this line.
- ⑥ : For left side piping, piping connection for gas should be about ⑥ from this line.

3 TO DRILL A HOLE IN THE WALL AND INSTALL A SLEEVE OF PIPING

- Insert the piping sleeve to the hole.
- Fix the bushing to the sleeve.
- Cut the sleeve until it extrudes about 19/32" (15 mm) from the wall.



5 CONNECT THE CABLE TO THE INDOOR UNIT

- The inside and outside connection cable can be connected without removing the front grille.
- Unscrew the conduit cover and fix the conduit connector to conduit cover with lock nut, then secure it against chassis.
- Connection cable between indoor unit and outdoor unit should be UL listed or CSA approved 4 conductor wires minimum AWG16 in accordance with local electric codes.

Terminals on the indoor unit	1	2	3
Colour of wires (connection cable)	1	2	3
Terminals on the outdoor unit	1	2	3

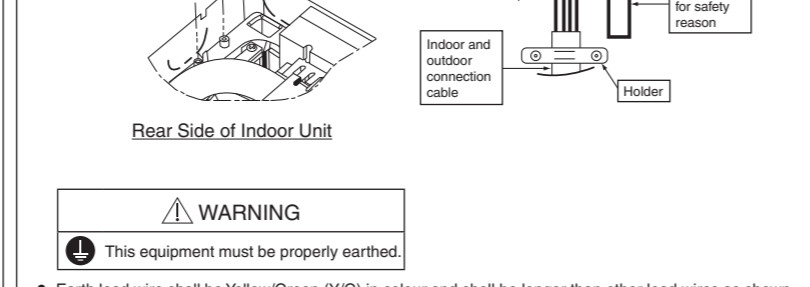

WIRE STRIPPING AND CONNECTING REQUIREMENT

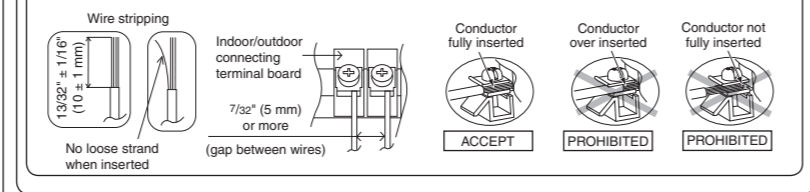

CUTTING AND FLARING THE PIPING

- Please cut using pipe cutter and then remove the burrs.
- Remove the burrs by using reamer. If burrs are not removed, gas leakage may be caused. Turn the piping end down to avoid the metal powder entering the pipe.
- Please make flare after inserting the flare nut onto the copper pipes.

INDOOR UNIT INSTALLATION

4 INDOOR UNIT INSTALLATION

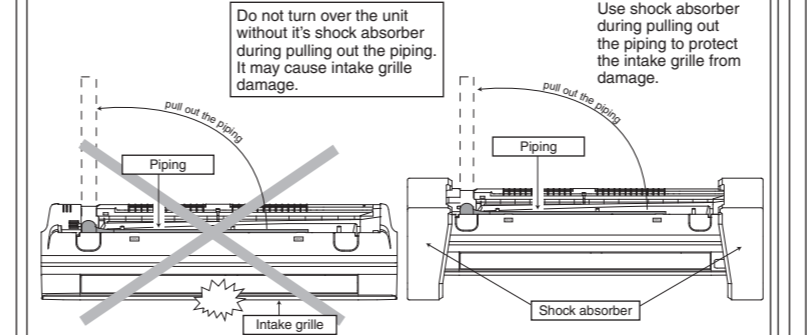

- FOR THE RIGHT REAR PIPING**
 - Pull out the Indoor piping
 - Install the Indoor Unit
 - Secure the Indoor Unit
 - Insert the connection cable

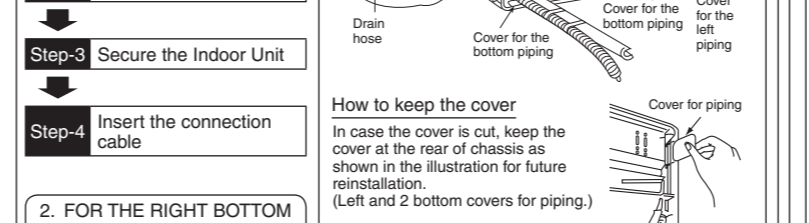

- FOR THE RIGHT BOTTOM PIPING**
 - Pull out the Indoor piping
 - Install the Indoor Unit
 - Insert the connection cable
 - Secure the Indoor Unit

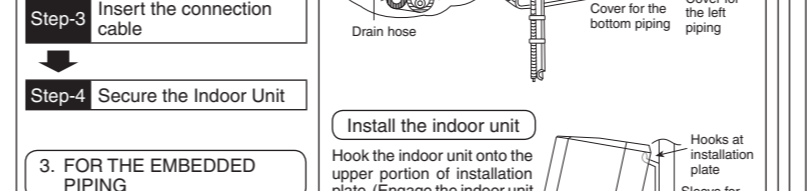

3. FOR THE EMBEDDED PIPING

- Replace the drain hose
- Band the embedded piping
- Pull the connection cable into Indoor Unit
- Cut and flare the embedded piping

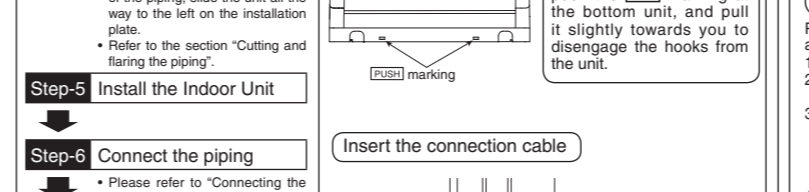

- Connect the piping
- Insulate and finish the piping
- Secure the Indoor Unit

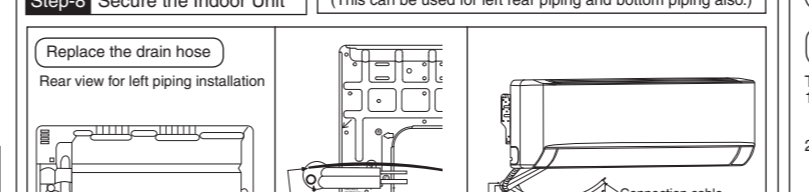

- How to pull the piping and drain hose out, in case of embedded piping.
- How to insert the connection cable and drain hose in the case of left piping.

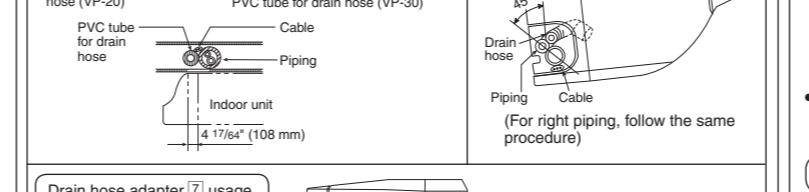
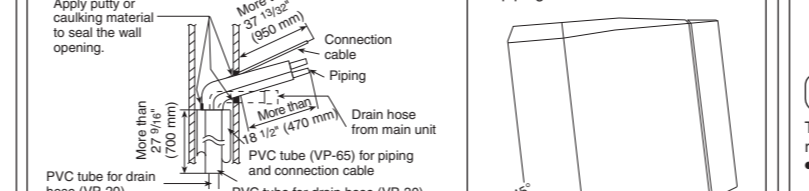

- Remarks: Make sure indoor unit drain hose is 3/4" (20 mm) nominal PVC pipe size by using drain hose adapter [7] when necessary.
- Close join by Vinyl Tape [8]

OUTDOOR UNIT

1 SELECT THE BEST LOCATION

(Refer to "Select the best location" section)

2 INSTALL THE OUTDOOR UNIT

- After selecting the best location, start installation to Indoor/Outdoor Unit Installation Diagram.
- Fix the unit on concrete or rigid frame firmly and horizontally with a bolt nut ø13/32" (ø10 mm). When installing at top, please consider strong wind and earthquake. Please fasten the installation stand firmly with bolt or nails.

Model	Dimension			
	A	B	C	D
XE9***, XE12***	21 1/4" (540 mm)	6 19/64" (160 mm)	23 9/32" (18.5 mm)	12 63/64" (1330 mm)
XE15***	24 1/8" (613 mm)	5 5/32" (131 mm)	15 1/8" (24 mm)	14 3/16" (360.5 mm)

5 CONNECT THE CABLE TO THE OUTDOOR UNIT

- Remove Top panel.
- Remove control board cover (Resin and Metal).
- Remove plug.
- Fix the conduit connectors to the knockout holes with lock-nuts, then secure them against the side panel.
- All wires pass through conduits & particular plate's opening hole.
- Connection wires between indoor unit and outdoor unit should be UL listed or CSA approved 4 conductor wires minimum AWG16 in accordance with local electric codes.
- Wire connection to the power supply (208/230V 60Hz) through circuit breaker.
 - Connect the UL listed or CSA approved wires minimum AWG14 to the terminal board, and connect the other end of the wires to ELCB(GFCI).
- Connect the power supply cord and connection wires between indoor unit and outdoor unit according to the diagram below.
- Secure the wire onto the control board with the holder (clammer).
- After completing wiring connections, reattach the particular plate and control board cover (metal and resin) to the original position with the screws.
- For wire stripping and connection requirement, refer to instruction ③ of indoor unit.

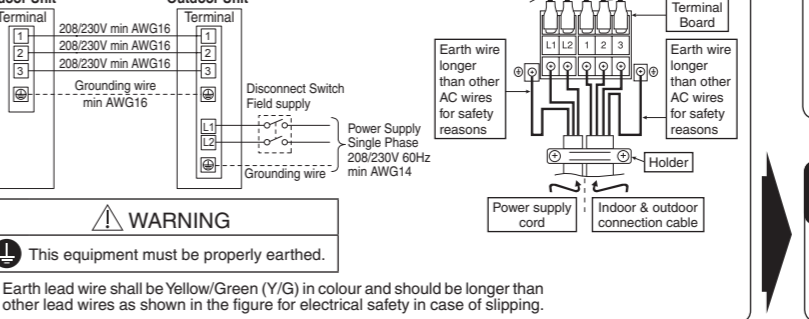

HOW TO TAKE OUT FRONT GRILLE

- Set the vertical airflow direction vane to the horizontal position.
- Remove the 2 caps on the front grille as shown in the illustration at right, and then remove the 2 mounting screws.
- Remove screw on the right side of airflow vane.
- Slide the lever, from locked position into released position. Take out vane.

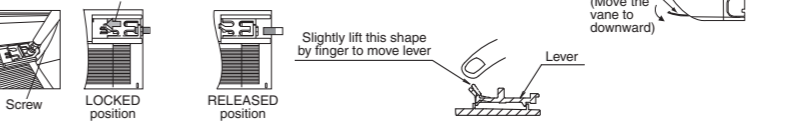

AUTO SWITCH OPERATION

- The below operations will be performed by pressing the "AUTO" switch.
- AUTO OPERATION MODE**
 - The Auto operation will be activated immediately once the Auto Switch is pressed and released before 5 sec.
- TEST RUN OPERATION (FOR PUMP DOWN/SERVICING PURPOSE)**
 - The Test Run operation will be activated if the Auto Switch is pressed continuously for more than 5 sec. to below 8 sec.
 - A "pep" sound will occur at the fifth sec., in order to identify the starting of Test Run operation.
- HEATING TRIAL OPERATION**
 - Press the "AUTO" switch continuously for more than 8 sec. and release when a "pep" sound is occurred at eight sec. (However, a "pep" sound is heard at fifth sec.) then press Remote controller "AC Reset" button once. Remote controller signal will activate operation force heating mode.
- REMOTE CONTROLLER RECEIVING SOUND ON/OFF**
 - The ON/OFF of Remote controller receiving sound can be changed by the following steps:
 - Press "AUTO" switch continuously for more than 16 sec. A "pep" "pep" "pep" sound will occur at the sixteenth sec.
 - Press the "AC Reset" button once, "pep" sound will occur indicates that Remote controller receiving sound setting mode is activated.
 - Press "AUTO" switch again. Everytime "AUTO" switch is pressed (within 60 sec. interval), Remote controller receiving sound status will be reversed between ON and OFF.
 - Long "pep" sound indicates that Remote controller receiving sound is ON.
 - Short "pep" sound indicates that Remote controller receiving sound is OFF.

DISPOSAL OF OUTDOOR UNIT DRAIN WATER

- The unit should be mounted on a stand that suits to a local environmental requirement.
- When the Drain elbow [5] being used, please ensure to:
 - Seal the minimum clearance of 2" (50mm) to access the bottom of base pan.
 - Seal the four 25/32" (20 mm) diameter holes with Rubber caps [9] (refer to illustration at right).
 - Use a rigid or flexible PVC pipe (local supply) to dispose drained water from the elbow or use a stainless steel tray (local supply) to collect and dispose water.
- If the unit is used in an area where temperature falls below 32°F (0°C) for 2 or 3 consecutive days, it is recommended not to use the Drain elbow [5] and Rubber caps [9]. water from defrost process will trap, freeze up and obstruct fan rotation. Water may drip from the basepan hole area during defrost function, do not stand or place objects underneath.

CHECK THE DRAINAGE

- Open front panel and remove air filters.
- Drainage checking can be carried out without removing the front grille.
- Pour a glass of water into the drain tray-styrofoam.
- Ensure that water flows out from drain hose of the indoor unit.

EVALUATION OF THE PERFORMANCE

- Operate the unit at cooling/heating operation mode for fifteen minutes or more.
- Measure the temperature of the intake and discharge air.
- Ensure the difference between the intake temperature and the discharge is more than 46.4°F (8°C) during Cooling operation or more than 57.2°F (14°C) during Heating operation.

CONNECT THE PIPING

3 CONNECT THE PIPING

- Connecting The Piping to Indoor
 - Please make flare after inserting flare nut (locate at joint portion of tube assembly) onto the copper pipe. (In case of using long piping)
 - Connect the piping
 - Align the center of piping and sufficiently tighten the flare nut with fingers.
 - Further tighten the flare nut with torque wrench in specified torque as stated in the table.

Piping size	Torque	
	Spanner	Wrench
1/4" (6.35 mm)	13.3 lbf·ft (1.8 kgf·m)	3.0 lbf·ft (0.4 kgf·m)
3/8" (9.52 mm)	31.0 lbf·ft (4.2 kgf·m)	7.5 lbf·ft (1.0 kgf·m)
1/2" (12.7 mm)	40.6 lbf·ft (5.5 kgf·m)	10.1 lbf·ft (1.4 kgf·m)
5/8" (15.88 mm)	47.6 lbf·ft (6.5 kgf·m)	11.9 lbf·ft (1.6 kgf·m)
3/4" (19.05 mm)	73.8 lbf·ft (10.0 kgf·m)	18.5 lbf·ft (2.5 kgf·m)

4 EVACUATION OF THE EQUIPMENT

- WHEN INSTALLING AN AIR CONDITIONER, BE SURE TO EVACUATE THE AIR INSIDE THE INDOOR UNIT AND PIPES IN THE FOLLOWING PROCEDURE.

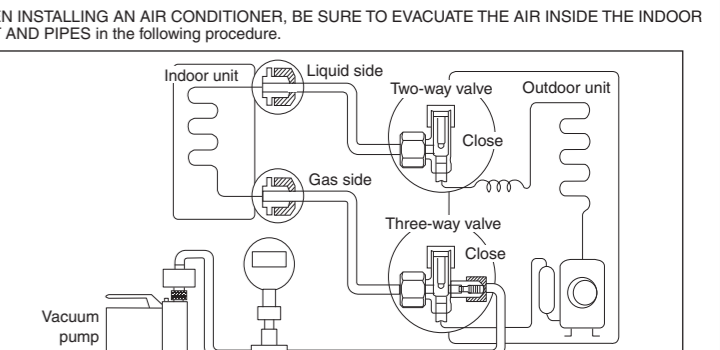

- Connect a charging hose with a push pin to the Low side of a charging set and the service port of the 3-way valve.
- Connect the micron gauge between vacuum pump and service port of outdoor units.
- Turn on the power switch of the vacuum pump and make sure that connect digital micron gauge and to pull down to a value of 500 microns.
- Make sure micron gauge a value 500 microns and close the low side valve of the charging set and turn off the vacuum pump.
- Disconnect the vacuum pump hose from the service port of the 3-way valve.
- Tighten the service port caps of the 3-way valve at a torque of 13.3 lbf·ft (1.8 Nm) with a torque wrench.
- Remove the valve caps of both of the 2-way valve and 3-way valve. Position both of the valves to "Open" using a hexagonal wrench (5/32" (4 mm)).
- Mount valve caps onto the 2-way valve and the 3-way valve.

- Be sure to check for gas leakage.
- If micron gauge value does not descend 500 microns, take the following measures:
 - If the leak stops when the piping connections are tightened further, continue working from step ③.
 - If the leak does not stop when the connections are retightened, repair location of leak.
 - Do not release refrigerant during piping work for installation and reinstallation.
 - Be careful with the liquid refrigerant, it may cause frostbite.

6 PIPING INSULATION

- Please carry out insulation at pipe connection portion as mentioned in Indoor/Outdoor Unit Installation Diagram. Please wrap the insulated part end to prevent water from going inside the piping.
- If drain hose or connecting piping is in the room (where dew may form), please increase the insulation by using POLY-E FOAM with thickness 1/4" (6 mm) or above.

HOW TO REPLACE NETWORK ADAPTER

- Remove the front grille (refer how to take out front grille) from the unit.
- Remove the network adapter box by releasing the hook (Figure 1.0).
- Remove the cover by unclipping it and pulling it out (Figure 1.1).
- Remove the top casing by pressing the side of the network adapter box. (Figure 1.2)
- After that, network adapter can be easily replaced (Figure 1.3).

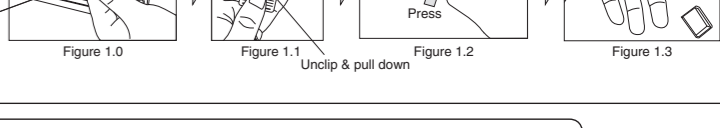

IN CASE OF REUSING EXISTING REFRIGERANT PIPING

- Observe the followings to decide reusing the existing refrigerant piping.
 - Poor refrigerant piping could result in product failure.
 - In the circumstances listed below, do not reuse any refrigerant piping. Instead, make sure to install a new piping.
 - The existing refrigerant piping is not provided for either liquid-side or gas-side piping or both.
 - The existing refrigerant pipe has been left in an open condition.
 - The diameter and thickness of the existing refrigerant piping does not meet the requirement.
 - The piping length and electrical wiring does not meet the requirement.
 - Perform proper pump down before reuse piping.
 - In the circumstances listed below, clean it thoroughly before reuse.
 - Pump down operation cannot be performed for the existing air-conditioner.
 - The compressor has a failure history.
 - Oil color is darkened. (ASTM 4.0 and above).
 - The existing air-conditioner is gas/oil heat pump type.
 - Do not reuse the flare to prevent gas leak. Make sure to install a new flare.
 - If there is a welded part on the existing refrigerant piping, conduct a gas leak check on the welded part.
 - Replace deteriorated heat insulating material with a new one.
 - Heat insulating material is required for both liquid-side and gas-side piping.

Proper Pump Down Method

- Operate air conditioner at cooling mode for 10 - 15 minutes.
- After 10 - 15 minutes of pre operation, close 2 way valve. After 3 minutes, close 3 way valve.
- Take out air conditioner unit.
- Install New Refrigerant air conditioner.

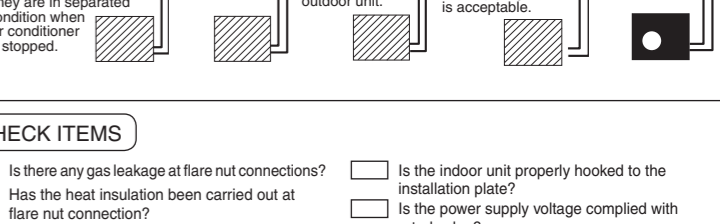

CHECK ITEMS

- Is there any gas leakage at flare nut connections?
- Has the heat insulation been carried out at flare nut connection?
- Is the connection cable being fixed to terminal board firmly?
- Is the connection cable being clamped firmly?
- Is the drainage OK?
- Is the earth wire connection properly done?
- Is the indoor unit properly hooked to the installation plate?
- Is the power supply voltage complied with rated value?
- Is there any abnormal sound?
- Is the cooling/heating operation normal?
- Is the thermostat operation normal?
- Is the remote control's LCD operation normal?